

On the behaviour of a suspension of conducting particles subjected to a time-periodic magnetic field

By H. K. MOFFATT

Department of Applied Mathematics & Theoretical Physics, University of Cambridge,
Silver Street, Cambridge CB3 9EW, UK

(Received 23 January 1990)

The force $F(x)$ and torque $G(x)$ acting on a conducting body or particle suspended at position x in a magnetic field $\text{Re}(\hat{B}_0(x)e^{-i\omega t})$ are determined to leading order in the ratio of the scale a of the particle to the scale L of the field. When the particle is spherical, F decomposes naturally into an irrotational ‘lift’ force F^L and a solenoidal ‘drag’ force F^D related to G by

$$F^D + \frac{1}{2}\nabla \wedge G = 0.$$

This relationship is important when the action of the field on a suspension of such spheres is considered, because it implies that the *net* effective force per unit volume acting to generate bulk flow is zero in any region where the concentration c is uniform. However, non-uniformity is generated by the force ingredient F^L and bulk flow is then generated through interaction of G and ∇c . These effects are demonstrated for two examples involving rotating and travelling fields. Interactions of a finite number N of spheres are also considered, and in particular it is shown that when the field is a uniform rotating one, the governing dynamical system is at leading order Hamiltonian with four independent integral invariants. When $N \geq 4$, the system in general exhibits chaos.

1. Introduction

When an electrically conducting particle is suspended in an a.c. (time-periodic) magnetic field, electric currents are induced in the particle; these interact with the applied field to give a Lorentz force distribution, which has a mean (i.e. time-averaged) part, and a fluctuating part. There is then in general a total mean force F and torque (or couple) G acting on the particle.

Although this type of induction problem is classical in character (Lamb 1883), there are certain features that do not seem to be widely understood. The features that we shall focus on in this paper are well illustrated by three different configurations, sketched in figure 1 (*a-c*), which are believed to be prototypical. The first (figure 1*a*) is the rotating field configuration, in which a uniform field is caused to rotate with angular velocity ω by the use of three-phase windings in the external coils carrying the source currents. If a conducting sphere is suspended in this field, then it experiences a torque G tending to rotate it in the same sense as the rotation of the field. If the sphere is suspended on a wire, it will rotate until the electromagnetic torque is balanced by the torque transmitted through the twisted wire and will then attain a position of equilibrium. This mechanism was first identified by Braunbeck (1932). If, on the other hand, it is suspended in a (non-conducting) viscous fluid, then it will rotate with angular velocity Ω determined by

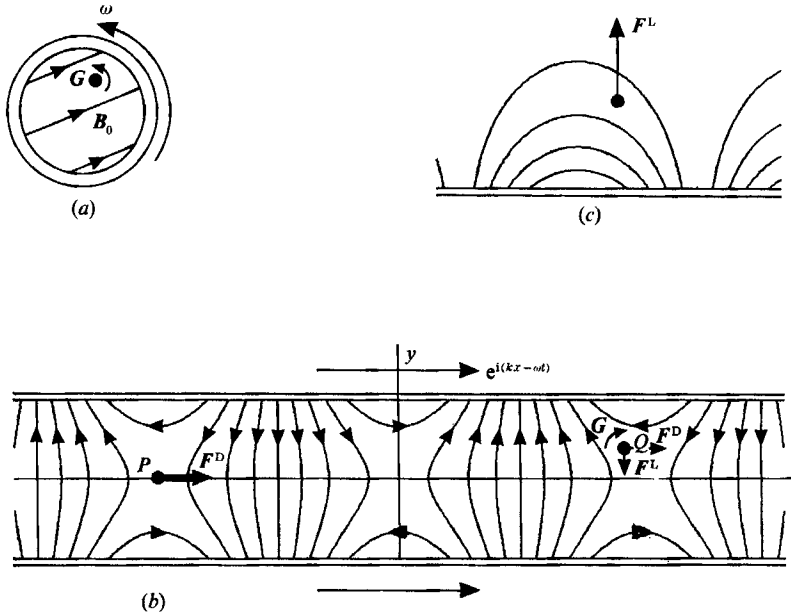

FIGURE 1. Prototype fields, and their effect on a suspended sphere: (a) rotating field; (b) travelling field; (c) levitating field.

the condition that the sum of the electromagnetic and viscous torques acting on the sphere be zero.

The second configuration (figure 1*b*) is that of the travelling field, in which the applied field has a progressive wave form $\sim e^{i(kx - \omega t)}$, again through the use of three-phase external windings. If a conducting sphere is placed in the symmetric position *P* indicated in the figure, then it experiences a 'drag force' F^D in the direction of travel of the wave, and tending to accelerate the sphere in this direction. If the sphere is surrounded by viscous fluid, then this acceleration will be arrested when the force F^D is balanced by the viscous drag acting on the sphere.

The third configuration (figure 1*c*) is that of the 'levitating field' which may be produced by single-phase source currents. There is then a levitating or 'lift' force F^L acting on a suspended sphere in the direction indicated.

In more general situations, we shall find that the body experiences a torque G and both force ingredients F^D and F^L simultaneously. (For example the sphere in the non-symmetric position *Q* in figure 1*b* experiences a force $F^D + F^L$ and a torque G in the sense indicated.) These depend on the position vector x of the centre of the sphere, and we shall find that there is a simple relation between the force ingredient $F^D(x)$ and the torque $G(x)$, namely,

$$F^D = -\frac{1}{2}\nabla \wedge G. \quad (1.1)$$

It is worth noting that in both the problems of figures 1*a*) and 1*b*), it is the *relative* motion between sphere and field which leads to induced currents and so to the Lorentz force distribution. Thus, in the travelling field case (figure 1*b*), in a frame of reference moving with the field (i.e. with velocity $V = (\omega/k, 0, 0)$), the field is at rest, and the sphere moves with velocity $-V$. The mean drag force F^D acting on the sphere is of course unaffected by this change of viewpoint (provided $V/c \ll 1$ and relativistic effects are negligible).

The rotating field case (figure 1*a*) is a little more subtle. Relative to a frame of reference rotating with angular velocity ω , the field is at rest, and the sphere moves in a circular orbit with angular velocity $-\omega$ with synchronous rotation relative to its centre (so that the same point of the sphere is always nearest to the centre of its circular orbit). The motion of the sphere thus consists of translation \mathbf{V} plus rotation $-\omega$, but it is only the rotation (or 'spin') that induces currents (the translationally induced electromagnetic force $\mathbf{V} \wedge \mathbf{B}$ being annulled by an electric field $\mathbf{E} = -\mathbf{V} \wedge \mathbf{B}$ established in the moving conductor by the spontaneous appearance of a surface charge distribution). The torque \mathbf{G} acting on the sphere is then associated with its spin alone, and does not depend on the radius of its orbital motion.

The theory for determination of \mathbf{F}^D , \mathbf{F}^L and \mathbf{G} will be developed within a general framework in §2, under the assumption that the conductor is small in linear extent compared with the lengthscale of variation of the applied field; the case of a spherical conductor is solved completely.

This theory serves as a preliminary for consideration of the effect of a time-periodic field on a dilute suspension of conducting particles. This problem is interesting from a fundamental point of view, because it is one of the few situations in which a torque distribution per unit volume (as opposed to a force distribution per unit volume) may be applied to a medium, the resulting stress tensor then being non-symmetric. (There are here some points of contact with the theory of ferrofluids in rotating fields – see Rosensweig 1985, chap. 8.)

We start in §3 with consideration of the problem of a suspension of N spheres in a viscous fluid permeated by a uniform rotating magnetic field. Interactions between the spheres are two-fold: first, each sphere tends to move with the local fluid velocity resulting from rotation of all the other spheres – in this, the behaviour is very like the ' N -vortex' problem of classical hydrodynamics in which each vortex moves in the velocity field associated with the others. There is however a second effect, relatively weak for a dilute system, arising from the fact that each sphere 'sees' not a uniform magnetic field but a field distorted by the presence of the other spheres, and therefore experiences a force \mathbf{F} as well as a torque \mathbf{G} . This effect is analysed for the two-sphere problem, and the sphere trajectories calculated.

When the system is sufficiently dilute for the latter effect to be negligible, the N -sphere problem is indeed closely analogous to the N -vortex problem. When the Reynolds number based on the spin angular velocity $\boldsymbol{\Omega}$ of each sphere is small, the sphere centres all move in planes perpendicular to $\boldsymbol{\Omega}$, the associated dynamical system being Hamiltonian and autonomous (§4). As well as the Hamiltonian H , there are three further invariants, the 3-sphere problem being integrable, and the N -sphere problem in general non-integrable for $N \geq 4$. Thus when $N \geq 4$, and when the initial configuration has no particular symmetry, each sphere follows a chaotic trajectory in the plane to which it is confined.

The suspension proper (with concentration $c \ll 1$) is treated in §§5 and 6. The force ingredients \mathbf{F}^L and \mathbf{F}^D translate into force densities $c\tilde{\mathbf{F}}^L$ and $c\tilde{\mathbf{F}}^D$ where, for a suspension of spheres, $\tilde{\mathbf{F}}^L$ and $\tilde{\mathbf{F}}^D$ are respectively irrotational and solenoidal. There is also a torque density $c\tilde{\mathbf{G}}$, and the *effective* force density driving a bulk flow is

$$c\tilde{\mathbf{F}}^L + c\tilde{\mathbf{F}}^D + \frac{1}{2}\nabla \wedge (c\tilde{\mathbf{G}}). \quad (1.2)$$

When c is uniform, and when the suspended particles are spheres, this effective force is irrotational (this follows from (1.1)) and no bulk flow arises. However, the levitating force $c\tilde{\mathbf{F}}^L$ generates inhomogeneities of concentration which then interact

with $\tilde{\mathbf{G}}$ through the term $-\frac{1}{2}\tilde{\mathbf{G}} \wedge \nabla c$ to produce a bulk flow. This flow is determined in §6 for the case of a rotating multipole field, and for the travelling field. The various threads are drawn together in the concluding §7.

2. Action of a time-periodic magnetic field on a conducting particle

Consider then a time-periodic magnetic field of the form

$$\mathbf{B}_0(\mathbf{x}, t) = \mathbf{B}_0^{(r)}(\mathbf{x}) \cos \omega t + \mathbf{B}_0^{(i)}(\mathbf{x}) \sin \omega t = \text{Re} (\hat{\mathbf{B}}_0(\mathbf{x}) e^{-i\omega t}), \quad (2.1)$$

where $\hat{\mathbf{B}}_0 = \mathbf{B}_0^{(r)} + i\mathbf{B}_0^{(i)}$. In what follows, the real part of expressions like $\hat{\mathbf{B}}_0 e^{-i\omega t}$ will be understood. In the special situation in which $\mathbf{B}_0^{(i)}(\mathbf{x})$ and $\mathbf{B}_0^{(r)}(\mathbf{x})$ are everywhere parallel, we may write $\hat{\mathbf{B}}_0 = \mathbf{B}_0^{(T)} e^{i\phi(\mathbf{x})}$, so that

$$\mathbf{B}_0(\mathbf{x}, t) = \mathbf{B}_0^{(T)}(\mathbf{x}) \cos(\phi(\mathbf{x}) - \omega t), \quad (2.2)$$

and the field is a *single-phase* field. Generally, however, $\mathbf{B}_0^{(i)}$ and $\mathbf{B}_0^{(r)}$ are non-parallel, and we have a *multiphase* field. Note that, with $*$ representing a complex conjugate,

$$i\hat{\mathbf{B}}_0 \wedge \hat{\mathbf{B}}_0^* = 2\mathbf{B}_0^{(r)} \wedge \mathbf{B}_0^{(i)}, \quad (2.3)$$

and this is real and non-zero for a multiphase field.

We suppose that the field $\mathbf{B}_0(\mathbf{x}, t)$ is produced by a system of currents in coils or conductors that are external to a domain \mathcal{D} in which the background medium is non-conducting. Hence $\hat{\mathbf{B}}_0(\mathbf{x})$ is a potential field in \mathcal{D} , i.e.

$$\hat{\mathbf{B}}_0(\mathbf{x}) = \nabla \hat{\Psi}_0, \quad \nabla^2 \hat{\Psi}_0 = 0, \quad (2.4)$$

where $\hat{\Psi}_0(\mathbf{x})$ is a complex-valued scalar field. The lengthscale L characteristic of variation of $\hat{\mathbf{B}}_0$ (defined by $L^{-1} \sim \|\nabla \hat{\mathbf{B}}_0\|/\|\hat{\mathbf{B}}_0\|$ where $\|\dots\|$ is some suitably defined norm) is determined by the scale and remoteness of the source currents.

Suppose now that we introduce a particle of linear scale a small compared with L , and uniform conductivity σ , into this field. Let $\delta = (2/\mu_0 \sigma \omega)^{\frac{1}{2}}$ where $\mu_0 = 4\pi \times 10^{-7}$ (S.I. units), and let

$$\lambda = a/\delta = (\frac{1}{2}a^2\mu_0 \sigma \omega)^{\frac{1}{2}}, \quad (2.5)$$

a dimensionless parameter which plays an important part in what follows. When $\lambda \gg 1$, δ is the familiar skin depth to which the magnetic field penetrates. When $\lambda \lesssim 1$, the field penetrates throughout the conductor.

Let $\mathbf{j}(\mathbf{x}, t) = \hat{\mathbf{j}}(\mathbf{x}) e^{-i\omega t}$ be the current induced in the particle. Then the dipole moment of the associated magnetic field is $\boldsymbol{\mu}(t) = \hat{\boldsymbol{\mu}} e^{-i\omega t}$ where

$$\hat{\boldsymbol{\mu}} = \frac{1}{2} \int_V \mathbf{x} \wedge \hat{\mathbf{j}}(\mathbf{x}) dV, \quad (2.6)$$

V being the volume occupied by the particle. Since the induction problem is linear, there must exist a linear relationship between $\hat{\boldsymbol{\mu}}$ and $\hat{\mathbf{B}}_0(\mathbf{x})$. Taking origin at the centre of volume of the particle, this linear relationship may be expressed in terms of the value of $\hat{\mathbf{B}}_0$ and its derivatives at $\mathbf{x} = 0$:

$$\hat{\mu}_i = 4\pi\mu_0^{-1} a^3 \left[\alpha_{ij} \hat{B}_{0j} + a\beta_{ijk} \frac{\partial \hat{B}_{0j}}{\partial x_k} + a^2 \gamma_{ijkl} \frac{\partial^2 \hat{B}_{0j}}{\partial x_k \partial x_l} + \dots \right]_{\mathbf{x}=0}, \quad (2.7)$$

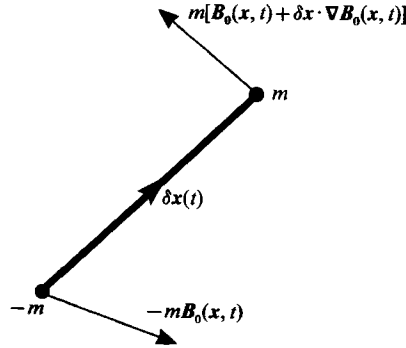

FIGURE 2. Elementary representation of a dipole in terms of magnetic poles $\pm m$ at separation δx . The resultant force F and torque G are given by (2.10).

where $\alpha_{ij}, \beta_{ijk}, \dots$ are dimensionless tensor coefficients dependent on λ and on the shape of the particle. This is effectively a power series in the small parameter a/L , since the n th derivatives of \hat{B}_0 are of order $L^{-n}|\hat{B}_0|$.

If the particle is spherical, then there is a remarkable simplification† of the series (2.7); for then the tensors $\alpha_{ij}, \beta_{ijk}, \dots$ must be isotropic, i.e.

$$\alpha_{ij} = \alpha \delta_{ij}, \quad \beta_{ijk} = 0, \quad \gamma_{ijkl} = \gamma^{(1)} \delta_{ij} \delta_{kl} + \gamma^{(2)} \delta_{ik} \delta_{jl} + \gamma^{(3)} \delta_{il} \delta_{jk}, \dots \quad (2.8)$$

Hence, firstly, all the odd-derivative terms of (2.7) vanish. Secondly, since $\nabla \cdot \hat{B}_0 = 0$ and (from (2.4)) $\nabla^2 \hat{B}_0 = 0$, each contribution to the third term of (2.7) vanishes, and *a fortiori*, all higher-order even-derivative terms vanish also! Hence we are left with

$$\hat{\mu} = 4\pi\mu_0^{-1} \alpha a^3 \hat{B}_0, \quad (2.9)$$

where $\alpha(\lambda)$ is a complex-valued scalar, which may be described as the ‘induction coefficient’. It is important to emphasize here that \hat{B}_0 in (2.9) is evaluated at the centre of symmetry of the particle, $x = 0$.

Consider now the mean force F and torque G acting on the particle. Regarding the dipole μ as a pair of magnetic poles $\pm m$ at vector separation δx (figure 2), elementary considerations give

$$\left. \begin{aligned} F &= \langle \mu \cdot \nabla B_0 \rangle = \frac{1}{2} \text{Re} \left(\hat{\mu} \cdot \nabla \hat{B}_0^* \right) \\ G &= \langle \mu \wedge B_0 \rangle = \frac{1}{2} \text{Re} \left(\hat{\mu} \wedge \hat{B}_0^* \right) \end{aligned} \right\}, \quad (2.10)$$

and

where $\langle \dots \rangle$ denotes the time-average. A formal proof is given in Appendix A that these are indeed the correct expressions for F and G at leading order in a/L . Appendix A also indicates how corrections to these expressions at order $(a/L)^2$ (associated with the induced quadrupole) may be obtained.

Substituting (2.9) for the case of a sphere, we have immediately

$$F = 2\pi a^3 \mu_0^{-1} \text{Re} (\alpha \hat{B}_0 \cdot \nabla \hat{B}_0^*), \quad (2.11 a)$$

$$G = 2\pi a^3 \mu_0^{-1} \text{Re} (\alpha \hat{B}_0 \wedge \hat{B}_0^*). \quad (2.11 b)$$

Using (2.3), the expression for G may be written alternatively

$$G = 4\pi a^3 \mu_0^{-1} \alpha^{(1)} B_0^{(r)} \wedge B_0^{(1)}, \quad (2.12)$$

† It may be worth noting that the same simplification occurs if the particle has cubic symmetry or the symmetry of any other regular solid.

where $\alpha = \alpha^{(r)} + i\alpha^{(i)}$. Moreover, using (2.4) it is easy to show that $F = F^L + F^D$ where

$$F^L = 2\pi a^3 \mu_0^{-1} \alpha^{(r)} (\mathbf{B}_0^{(r)} \cdot \nabla \mathbf{B}_0^{(r)} + \mathbf{B}_0^{(i)} \cdot \nabla \mathbf{B}_0^{(i)}) = \pi a^3 \mu_0^{-1} \alpha^{(r)} \nabla |\hat{\mathbf{B}}_0|^2, \quad (2.13)$$

and
$$F^D = -2\pi a^3 \mu_0^{-1} \alpha^{(i)} \nabla \wedge (\mathbf{B}_0^{(r)} \wedge \mathbf{B}_0^{(i)}). \quad (2.14)$$

Here, and subsequently, F^L , F^D and G can be regarded as functions of the position \mathbf{x} at which the centre of the sphere is placed. Note that $F^L(\mathbf{x})$ is an irrotational force field, while $F^D(\mathbf{x})$ is solenoidal.

Note also that a non-zero torque G is associated with the imaginary part of α (i.e. with phase-lag between \mathbf{B}_0 and μ) and with non-parallel real and imaginary parts of $\hat{\mathbf{B}}_0$ (characteristic of a multiphase field). Such a field locally rotates with fluctuating amplitude and period $2\pi/\omega$ in the plane of $\mathbf{B}_0^{(r)}$ and $\mathbf{B}_0^{(i)}$. The field F^D is evidently related to G by

$$F^D + \frac{1}{2} \nabla \wedge G = 0. \quad (2.15)$$

This simple result holds however only under the isotropic condition $\alpha_{ij} = \alpha \delta_{ij}$.

Consider now the three prototype configurations of figure 1(a-c).

(a) *Rotating field* (figure 1a)

Let $\mathbf{B}_0^{(r)} = B_0(1, 0, 0)$, $\mathbf{B}_0^{(i)} = B_0(0, 1, 0)$ in Cartesian coordinates. Then

$$\mathbf{B}_0^{(r)} \wedge \mathbf{B}_0^{(i)} = B_0^2(0, 0, 1), \quad (2.16)$$

and so from (2.12)

$$G = 4\pi \mu_0^{-1} a^3 B_0^2 \alpha^{(i)}(0, 0, 1). \quad (2.17)$$

We expect that the torque should be in the same sense as the field rotation, i.e. $G_z > 0$, and so $\alpha^{(i)}(\lambda)$ should be positive for all λ . This is confirmed below. Note that, since \mathbf{B}_0 is uniform, $F = 0$ for this configuration.

(b) *Travelling field* (figure 1b)

Let

$$\hat{\Psi}_0(\mathbf{x}) = A e^{ikx} \sinh ky \quad (k > 0, |y| < b) \quad (2.18)$$

so that
$$\hat{\mathbf{B}}_0(\mathbf{x}) = \nabla \hat{\Psi}_0 = Ak(i \sinh ky, \cosh ky, 0) e^{ikx}. \quad (2.19)$$

Hence from (2.13) and (2.14), we find easily

$$F^L = 2\pi \mu_0^{-1} a^3 |A|^2 k^3 \alpha^{(r)} \sinh 2ky \hat{\mathbf{e}}_y, \quad (2.20)$$

and
$$F^D = 2\pi \mu_0^{-1} a^3 |A|^2 k^3 \alpha^{(i)} \cosh 2ky \hat{\mathbf{e}}_x. \quad (2.21)$$

Moreover, from (2.12),

$$G = -2\pi \mu_0^{-1} a^3 |A|^2 k^2 \alpha^{(i)} \sinh 2ky \hat{\mathbf{e}}_z. \quad (2.22)$$

Thus, for the sphere P in figure 1(b) on the plane of symmetry ($y = 0$) we have $F^L = 0$, $G = 0$, $F^D = 2\pi a^3 \mu_0^{-1} |A|^2 k^3 \alpha^{(i)} \hat{\mathbf{e}}_x$. Note that here, the in-phase component of the dipole moment gives a contribution to the force which averages to zero. For the sphere Q , however, F^L , F^D and G are all non-zero. Again, since, we expect the drag force F^D to be in the direction of travel of the field, i.e. the positive x -direction, we expect that $\alpha^{(i)}(\lambda) > 0$ for all λ .

As noted above, the result $F^D + \frac{1}{2} \nabla \wedge G = 0$ does not hold if α_{ij} is non-isotropic. In this more general situation, we define F^D as that part of the force involving the

imaginary part $\alpha_{ij}^{(i)}$ of α_{ij} . Then for example, if $\alpha_{ij} = \text{diag}(\alpha, \beta, \gamma)$, for the travelling field configuration we find

$$(\mathbf{F}^D + \frac{1}{2}\nabla \wedge \mathbf{G})_x = \pi a^3 \mu_0^{-1} |A|^2 k^3 (\alpha^{(i)} - \beta^{(i)}). \quad (2.23)$$

(c) *Levitating field* (figure 1c)

Let

$$\hat{\Psi}_0 = A \cos kx e^{-ky} \quad (k > 0, y > 0) \quad (2.24)$$

so that

$$\hat{\mathbf{B}}_0 = \nabla \hat{\Psi}_0 = -Ak(\sin kx, \cos kx, 0)e^{-ky}. \quad (2.25)$$

Then obviously $\hat{\mathbf{B}}_0 \wedge \hat{\mathbf{B}}_0^* = 0$, so that $\mathbf{G} = 0$ no matter where the sphere is placed, and so $\mathbf{F}^D = 0$ also. Here therefore it is the out-of-phase component of the dipole that gives a contribution to the force that averages to zero. However, from (2.13) we find an in-phase contribution:

$$\mathbf{F}^L = -2\pi\mu_0^{-1} a^3 \alpha^{(r)} |A|^2 k^3 e^{-2ky} \hat{\mathbf{e}}_y. \quad (2.26)$$

We expect that this force will be upwards since the mean magnetic pressure is greater on the lower surface of the sphere (where the mean field strength is greater). This means that $\alpha^{(r)}(\lambda)$ should be negative for all λ . This also is confirmed below. A sphere of mass m will then be levitated provided

$$2\pi\mu_0^{-1} a^3 |\alpha^{(r)}| |A|^2 k^3 > mg \quad (2.27)$$

and will then rise to an equilibrium height Y given by

$$Y = \frac{1}{2k} \ln \left(\frac{2\pi a^3 |\alpha^{(r)}| |A|^2 k^3}{mg\mu_0} \right). \quad (2.28)$$

It remains to find the function $\alpha(\lambda) = \alpha^{(r)}(\lambda) + i\alpha^{(i)}(\lambda)$. The details of this calculation are given in Appendix B, and the result in the case of a spherical particle is

$$\alpha^{(r)}(\lambda) = -\frac{1}{2} + \frac{3(\sinh 2\lambda - \sin 2\lambda)}{4\lambda(\cosh 2\lambda - \cos 2\lambda)}, \quad (2.29)$$

$$\alpha^{(i)}(\lambda) = -\frac{3}{4\lambda^2} + \frac{3(\sinh 2\lambda + \sin 2\lambda)}{4\lambda(\cosh 2\lambda - \cos 2\lambda)}. \quad (2.30)$$

These functions are plotted in figure 3, and the expectations $\alpha^{(r)}(\lambda) < 0$, $\alpha^{(i)}(\lambda) > 0$ for all λ are indeed confirmed. $\alpha^{(i)}$ has a maximum value $\alpha_{\text{max}}^{(i)} \approx 0.178$ when $\lambda \approx 2.4$. Note also the asymptotic behaviour:

$$(i) \lambda \ll 1: \quad \alpha^{(r)} \sim -\frac{4}{35}\lambda^4, \quad \alpha^{(i)} \sim \frac{1}{15}\lambda^2, \quad (2.31)$$

$$(ii) \lambda \gg 1: \quad \alpha^{(r)} \sim -\frac{1}{2} + \frac{3}{4\lambda}, \quad \alpha^{(i)} \sim \frac{3}{4\lambda} - \frac{3}{4\lambda^2}, \quad (2.32)$$

the last results being exact to within exponentially small terms. In the limit $\lambda = \infty$ (corresponding to a perfectly conducting sphere), $\alpha = -\frac{1}{2}$ and the field is totally expelled from the sphere; in this limit, both \mathbf{G} and \mathbf{F}^D are zero, but the lift force \mathbf{F}^L is generally non-zero.

Consider some orders of magnitude for the case of spheres of aluminium for which $\eta = (\mu_0 \sigma)^{-1} \approx 0.16 \text{ m}^2 \text{ s}^{-1}$. To achieve maximum drag or torque ($\lambda \approx 2.4$), we then

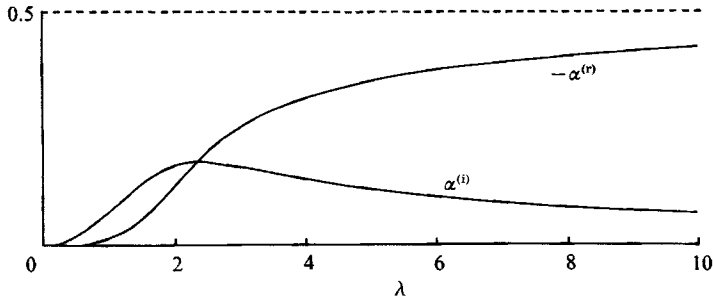

FIGURE 3. The real and imaginary parts of the induction function $\alpha(\lambda) = \alpha^{(r)}(\lambda) + i\alpha^{(i)}(\lambda)$ for a sphere.

require $a^2\omega \approx 1.8 \text{ m}^2 \text{ s}^{-1}$. For a frequency of the order of megahertz ($\omega \sim 10^6 \text{ s}^{-1}$), this is achieved with spheres of radius $a \approx 1.3 \text{ mm}$. If such spheres are suspended in a non-conducting liquid, they can be levitated by a field B of order $10^{-1} \text{ T} (= 10^3 \text{ G})$. Incidentally this would be an unconventional and rather dramatic method of heating the liquid! These orders of magnitude appear quite feasible, so that the effects described in this and subsequent sections should certainly be amenable to experimental verification. The effects must inevitably become much weaker as the particle size decreases if only because of the practical upper limits on the frequency and strength of magnetic fields that may be produced in the laboratory.

3. Interaction of two spheres suspended in a viscous fluid and subjected to a rotating field

We have seen that a single sphere subjected to a uniform field of strength B_0 , rotating in the (x, y) -plane, experiences a torque

$$\mathbf{G} = 4\pi a^3 \mu_0^{-1} B_0^2 \alpha^{(i)} \hat{\mathbf{e}}_z. \quad (3.1)$$

Suppose now that the sphere is surrounded by incompressible fluid of density ρ and kinematic viscosity ν ; that, under the action of the torque \mathbf{G} , it rotates with constant angular velocity $\boldsymbol{\Omega}$; and that the Reynolds number is small, i.e.

$$\text{Re} = \boldsymbol{\Omega} a^2 / \nu \ll 1, \quad (3.2)$$

so that all inertial effects are negligible. Then the velocity field in the fluid (see, for example, Landau & Lifshitz 1959, p. 68) is

$$\mathbf{u}(\mathbf{x}) = (\boldsymbol{\Omega} \wedge \mathbf{x}) (a/r)^3, \quad (3.3)$$

\mathbf{x} being measured from the centre of the sphere, and the viscous torque on the sphere is

$$\mathbf{G}_v = -8\pi\rho\nu a^3 \boldsymbol{\Omega}. \quad (3.4)$$

In equilibrium, $\mathbf{G} + \mathbf{G}_v = 0$, i.e.

$$\boldsymbol{\Omega} = (B_0^2 \alpha^{(i)} / 2\mu_0 \rho \nu) \hat{\mathbf{e}}_z, \quad (3.5)$$

and the condition (3.2) is satisfied provided

$$V_A^2 \alpha^{(i)} a^2 / 2\nu^2 \ll 1 \quad (3.6)$$

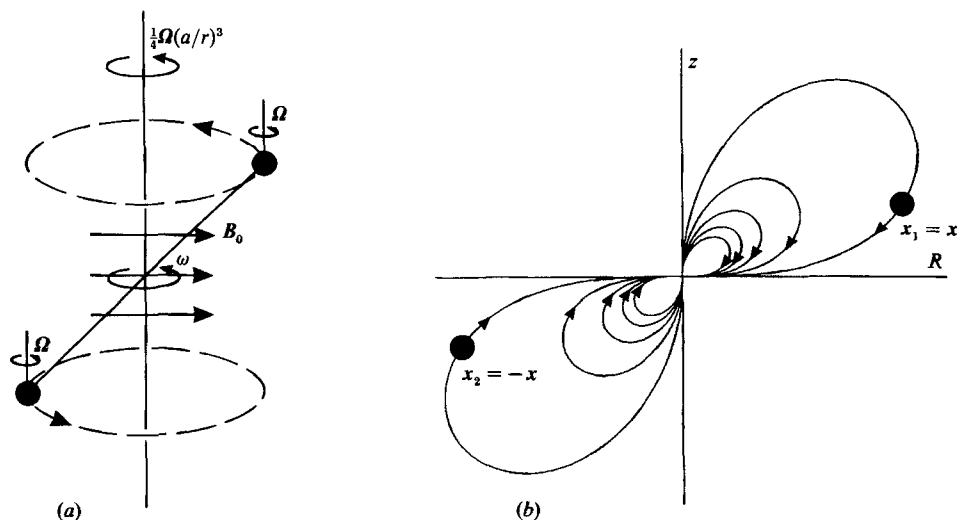

FIGURE 4. (a) Mutually induced rotation of two equal spheres subjected to a rotating magnetic field. Each sphere spins with angular velocity Ω (given by (3.5)) and moves in the couplet field (3.3) of the other sphere. (b) Meridional projections of sphere trajectories, as given by (3.16).

where $V_A = B_0/(\mu_0 \rho)^{1/2}$ is the Alfvén speed associated with B_0 . Note that the angular momentum of the sphere is instantaneously determined in this approximation.

This derivation is only valid provided the deduced angular velocity Ω is small in magnitude compared with the angular velocity ω of the field, since otherwise the fact that the particle is rotating would have to be taken into account† in the induction problem. This requires that

$$M^2 \ll 4\lambda^2/\alpha^{(1)}(\lambda), \tag{3.7}$$

where $M = V_A a/(\eta\nu)^{1/2}$ is the Hartmann number.

Suppose now that we have two equal spheres with centres at $\mathbf{x}_1(t)$ and $\mathbf{x}_2(t)$, where $|\mathbf{x}_1 - \mathbf{x}_2| \gg a$. Then the dominant interactive effect is given by the tendency of each sphere to move in the velocity field induced by rotation of the other. Consider first this effect alone; the equations of motion are then

$$\frac{d\mathbf{x}_1}{dt} = -\frac{d\mathbf{x}_2}{dt} = \boldsymbol{\Omega} \wedge (\mathbf{x}_1 - \mathbf{x}_2) \left(\frac{a}{r_{12}}\right)^3, \tag{3.8}$$

where $r_{12} = |\mathbf{x}_2 - \mathbf{x}_1|$. Hence the midpoint $\bar{\mathbf{x}} = \frac{1}{2}(\mathbf{x}_1 + \mathbf{x}_2)$ of the line of centres remains fixed. Taking this point as origin and $\mathbf{x}_1 = \mathbf{x}$, $\mathbf{x}_2 = -\mathbf{x}$, $r = |\mathbf{x}| = \frac{1}{2}r_{12}$, we have

$$\frac{d\mathbf{x}}{dt} = \frac{1}{4}(\boldsymbol{\Omega} \wedge \mathbf{x}) \left(\frac{a}{r}\right)^3, \tag{3.9}$$

so that r remains constant, and the point $\mathbf{x}(t)$ rotates about an axis through $\bar{\mathbf{x}} (= 0)$ with angular velocity $\frac{1}{4}\boldsymbol{\Omega}(a/r)^3$ (figure 4a).

There is a correction to this behaviour at higher order in (a/r) resulting from the fact that each sphere experiences a force $\pm F$ due to the magnetic field gradient

† It is not in fact difficult to do this – see Moffatt (1980) – since the ‘inducing’ angular velocity ω need merely be replaced by $\omega - \Omega$.

induced by the presence of the other sphere, thus giving an additional velocity $\pm V$ where, assuming a Stokes drag,

$$V = (6\pi\rho\nu a)^{-1} F. \quad (3.10)$$

The field in the neighbourhood of the sphere at $\mathbf{x}_1 (= \mathbf{x})$ is to good approximation the basic uniform field plus the dipole perturbation associated with the sphere at $\mathbf{x}_2 (= -\mathbf{x})$, i.e.

$$\hat{B}_i = \hat{B}_{0i} + \frac{1}{8}\alpha a^3 \hat{B}_{0j} \frac{\partial^2}{\partial x_i \partial x_j} \left(\frac{1}{r} \right). \quad (3.11)$$

From (2.11a), the force on sphere 1 is then

$$F_i = \frac{\pi a^6}{4\mu_0} |\alpha|^2 \operatorname{Re} (\hat{B}_{0j} \hat{B}_{0k}^*) \frac{\partial^3}{\partial x_i \partial x_j \partial x_k} \left(\frac{1}{r} \right). \quad (3.12)$$

With $\hat{B}_0 = (B_0/\sqrt{2})(1, i, 0)$, as appropriate for a field of strength B_0 rotating in the (x, y) -plane, this reduces to

$$F = \frac{3\pi a^6 |\alpha|^2 B_0^2}{8\mu_0 r^7} \{ (4z^2 - R^2) \mathbf{R} + (2z^2 - 3R^2) \mathbf{z} \}, \quad (3.13)$$

where $\mathbf{R} = (x, y, 0)$, $\mathbf{z} = (0, 0, z)$. Similarly, the force on sphere 2 is $-F$. The additional velocities $\pm V$ are then always in the meridian plane which rotates with the spheres. With coordinates (R, ϕ, z) (and $r^2 = R^2 + z^2$) the corrected vector equation

$$\frac{d\mathbf{x}}{dt} = \frac{1}{4}(\boldsymbol{\Omega} \wedge \mathbf{x}) \left(\frac{a}{r} \right)^3 + (6\pi\rho\nu a)^{-1} F \quad (3.14)$$

has components

$$\frac{dR}{dt} = C \frac{(4z^2 - R^2) R}{r^7}, \quad \frac{d\phi}{dt} = \frac{\Omega a^3}{4r^3}, \quad \frac{dz}{dt} = C \frac{(2z^2 - 3R^2) z}{r^7}, \quad (3.15a, b, c)$$

where $C = a^5 |\alpha|^2 V_A^2 / 16\nu\mu_0$. The R and z equations have an integral

$$\frac{zR^2}{(R^2 + z^2)^{\frac{3}{2}}} = \text{const.} \quad (3.16)$$

and the spheres therefore move on these curves on a meridian plane $\phi = \phi(t)$ which rotates according to (3.15b) (figure 4b). The description is of course valid only for so long as $r \gg a$.

Note that the ratio of the second term on the right of (3.14) to the first has order of magnitude

$$\frac{|(6\pi\rho\nu a)^{-1} F|}{\frac{1}{4}(\boldsymbol{\Omega} \wedge \mathbf{x})(a/r)^3} \sim \frac{|\alpha|^2}{\alpha^{(1)}} \left(\frac{a}{r} \right)^2 \quad (3.17)$$

and is small provided

$$\left(\frac{a}{r} \right)^2 \ll \frac{\alpha^{(1)}}{|\alpha|^2}. \quad (3.18)$$

Under this condition (satisfied provided λ is not too large), the relative drift associated with the forces $\pm F$ is weak. When more than two spheres are considered, the separation of any two centres changes because of perturbations associated with

other spheres, and it then seems reasonable to neglect the interactive force $\pm F$ in a first approximation.

There are of course further higher-order effects which we have ignored in the above treatment. For example, the velocity $-V$ of sphere 2 induces a velocity of order $|V(a/r)|$ in the neighbourhood of sphere 1; this leads to a further term on the right of (3.14), but smaller in order of magnitude than those already exhibited. Equation (3.14) is at best a reasonable approximation, uniformly valid (for all λ) when $a/r \ll 1$.

4. Interaction of N spheres

Suppose now that we have N equal spheres with centres at $\mathbf{x}_n(t)$ ($n = 1, 2, \dots, N$) and separations $r_{mn} = |\mathbf{x}_m - \mathbf{x}_n|$. Let r be the minimum separation; then under the condition (3.18), the equations of motion at leading order are

$$\frac{d\mathbf{x}_m}{dt} = \boldsymbol{\Omega} \wedge \sum'_n (\mathbf{x}_m - \mathbf{x}_n) \left(\frac{a}{r_{mn}}\right)^3, \tag{4.1}$$

where the prime on the summation indicates that the term for which $n = m$ is omitted. With $\boldsymbol{\Omega} = (0, 0, \Omega)$ and $\mathbf{x}_m = (x_m, y_m, z_m)$, we have immediately from (4.1)

$$\frac{dz_m}{dt} = 0, \quad \text{i.e. } z_m = Z_m(\text{const.}), \tag{4.2}$$

i.e. each sphere centre moves on a plane $z_m = Z_m$. Its coordinates on this plane are easily seen to satisfy

$$\frac{dx_m}{dt} = \frac{\partial H}{\partial y_m}, \quad \frac{dy_m}{dt} = -\frac{\partial H}{\partial x_m}, \tag{4.3}$$

where

$$H(x_m, y_m, Z_m) = \Omega a^3 \sum'_{m,n} r_{mn}^{-1}. \tag{4.4}$$

The equations (4.3) (for $m = 1, 2, \dots, N$) constitute an autonomous Hamiltonian system of order $2N$. An immediate integral is

$$H(x_m, y_m, Z_m) = \text{const.} \tag{4.5}$$

The similarity with the N -vortex problem of classical hydrodynamics is now clear, only the Hamiltonian H having different form. The following discussion is guided by that for the N -vortex problem (Aref 1984); it admits trivial extension to the case of N spheres of *different* radii and/or conductivities. Note first the obvious further integrals of the system (4.3), (4.4):

$$P = \sum x_m, \quad Q = \sum y_m, \quad D = \sum (x_m^2 + y_m^2). \tag{4.6}$$

Hence the three-sphere problem ($N = 3$) is described by a sixth-order system with four integrals, all of which are independent. It is therefore integrable, the m th sphere centre following a quasi-periodic orbit in the plane $z_m = Z_m$. Note however that inclusion of the weak forces of interaction $\pm F_{mn}$ between the spheres (as discussed in the previous section) will probably trigger chaotic behaviour even for the three-sphere system.

For $N = 4$, the system is eighth-order, with four independent integrals, and the motion of the sphere centres may be expected to be generally chaotic in these

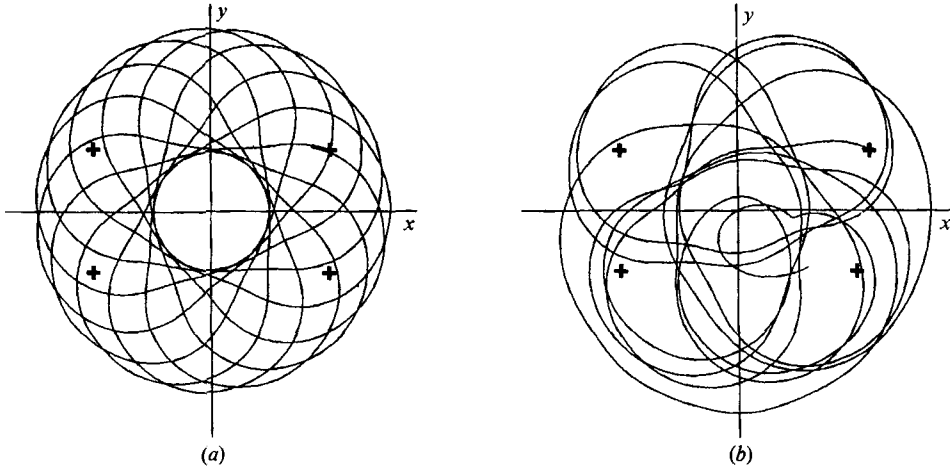

FIGURE 5. Trajectories for the four-sphere problem, each sphere moving in the couplet fields of the other three: (a) initial positions $(\pm 2, \pm 1)$ (marked by +); (b) same as (a) except that sphere at $(2, 1)$ is moved to initial position $(2.2, 1)$. $Z_n = 0$ for all n . Case (a) shows a quasi-periodic orbit; in (b) the symmetry is broken, and the orbit is chaotic.

circumstances. This prediction is qualitatively confirmed by numerical integration: figure 5(a) shows the orbit of one sphere starting from an initial condition in which the four spheres are at the corners of a rectangle $(\pm 2, \pm 1)$; here the symmetry of the system implies that $(x_3, y_3) = -(x_1, y_1)$ and $(x_4, y_4) = -(x_2, y_2)$ for all t , so that there are four degrees of freedom and two non-trivial integrals (H and D), the system being therefore integrable. If however the initial rectangle is perturbed (figure 5b), then the symmetry is broken and chaos ensues. Thus the behaviour is qualitatively similar to that of four interacting point vortices (Aref & Pomphrey 1982).

5. Behaviour of a dilute suspension of spheres

Suppose now that a dilute suspension of conducting spheres is contained in a fluid domain \mathcal{D} with fixed rigid boundary $\partial\mathcal{D}$, the whole being subjected to the general periodic magnetic field (2.1). We shall suppose that the volume concentration c of spheres is small ($c \ll 1$), and we shall allow for the possibility that c may be non-uniform and unsteady, i.e. $c = c(\mathbf{x}, t)$.

As shown in §2, each sphere experiences a force $\mathbf{F} = \mathbf{F}^L + \mathbf{F}^D$ and a torque \mathbf{G} given by (2.12)–(2.14). The torque is transmitted to the fluid by the Stokes mechanism described in §3; similarly the force \mathbf{F} is transmitted to the fluid through the relative velocity $\mathbf{V} = (6\pi\rho\nu a)^{-1}\mathbf{F}$ between sphere and fluid that it generates and the resulting Stokeslet flow. Viewed macroscopically, there is therefore a body force distribution $c(\tilde{\mathbf{F}}^L + \tilde{\mathbf{F}}^D)$ and a body torque distribution $c\tilde{\mathbf{G}}$ (both per unit volume) where

$$\tilde{\mathbf{F}}^L = \frac{3}{4}\mu_0^{-1}\alpha^{(r)}\nabla|\hat{\mathbf{B}}_0|^2, \quad \tilde{\mathbf{F}}^D = -\frac{1}{2}\nabla \wedge \tilde{\mathbf{G}}, \quad (5.1a, b)$$

$$\tilde{\mathbf{G}} = 3\mu_0^{-1}\alpha^{(l)}(\mathbf{B}_0^{(r)} \wedge \mathbf{B}_0^{(l)}). \quad (5.1c)$$

Note again that particle momentum and angular momentum are instantaneously determined in this approximation, effects of inertia being neglected.

It has been shown by Batchelor (1970) that, whenever a body torque distribution

$c\tilde{\mathbf{G}}(\mathbf{x})$ is present, angular momentum balance for a ‘macro-particle’ requires that the bulk stress tensor σ_{ij} must have an antisymmetric part given by

$$\sigma_{ij}^{(a)} = \frac{1}{2}(\sigma_{ij} - \sigma_{ji}) = \frac{1}{2}c_{ijk} c\tilde{\mathbf{G}}_k, \quad (5.2)$$

with a corresponding contribution to the Navier–Stokes equation

$$\frac{\partial}{\partial x_j} \sigma_{ij}^{(a)} = \frac{1}{2}[\nabla \wedge c\tilde{\mathbf{G}}]_i. \quad (5.3)$$

Hence the Navier–Stokes equation for the bulk motion $\mathbf{u}(\mathbf{x}, t)$ becomes

$$\rho \frac{D\mathbf{u}}{Dt} = -\nabla p + c\tilde{\mathbf{F}}^L + c\tilde{\mathbf{F}}^D + \frac{1}{2}\nabla \wedge c\tilde{\mathbf{G}} + \rho\nu\nabla^2\mathbf{u}. \quad (5.4)$$

If c is uniform, then the terms involving $\tilde{\mathbf{F}}^D$ and $\tilde{\mathbf{G}}$ exactly compensate by virtue of (5.1*b*); moreover, since $\tilde{\mathbf{F}}^L$ is irrotational, the term $c\tilde{\mathbf{F}}^L$ may be absorbed in the pressure term through definition of a modified pressure

$$P = p - \frac{3}{4}c(\mu_0\rho)^{-1}\alpha^{(r)}|\tilde{\mathbf{B}}_0|^2. \quad (5.5)$$

Apart from this pressure adjustment and the appearance of a (generally non-uniform) antisymmetric stress $\sigma_{ij}^{(a)}$, there is no effect at the macroscopic level, and in particular no macroscopic velocity field is generated. This is an astonishing conclusion, given that each conducting sphere generates a couplet and a Stokeslet by virtue of its rotation and translation relative to the fluid. It just so happens that $\tilde{\mathbf{F}}^D$ and $\tilde{\mathbf{G}}$ are related by the special condition $\tilde{\mathbf{F}}^D + \frac{1}{2}\nabla \wedge \tilde{\mathbf{G}} = \mathbf{0}$, which leads to vanishing of the rotational part of the mean driving force in (5.4) when c is uniform. Hence the net effect of superposition of all the couplets and Stokeslets is zero.

A similar conclusion has been reached in a related, but more restricted, context by Jansons (1983) who found that a homogeneous ferromagnetic fluid in a circular cylinder subjected to a *uniform* rotating magnetic field is not set in bulk rotation, although each microscopic dipole rotates with the field. The antisymmetric stress established in the fluid is absorbed at the boundary which exerts a couple equal and opposite to the integrated torque acting electromagnetically on the fluid. The fluid, although at rest (in bulk), is stressed in the same way as would be an elastic medium subjected to a torque in \mathcal{D} but fixed on $\partial\mathcal{D}$. The way in which the phenomenon of magnetically induced rotation may be applied in the context of viscometry has been discussed by Brancher (1988).

6. Role of the particle force F in generating inhomogeneity

Each sphere in the suspension considered moves with velocity $V = V^L + V^D$ relative to the background fluid where

$$V^L = (6\pi\nu\rho a)^{-1}F^L, \quad V^D = (6\pi\nu\rho a)^{-1}F^D, \quad (6.1a, b)$$

with

$$\nabla \wedge V^L = 0, \quad \nabla \cdot V^D = 0. \quad (6.2)$$

This relative velocity is large compared with any bulk velocity generated, which is at most of order $|\nabla c|$. Hence $c(\mathbf{x}, t)$ satisfies a conservation equation which, at leading order, is

$$\frac{\partial c}{\partial t} + \nabla \cdot (Vc) = 0, \quad (6.3)$$

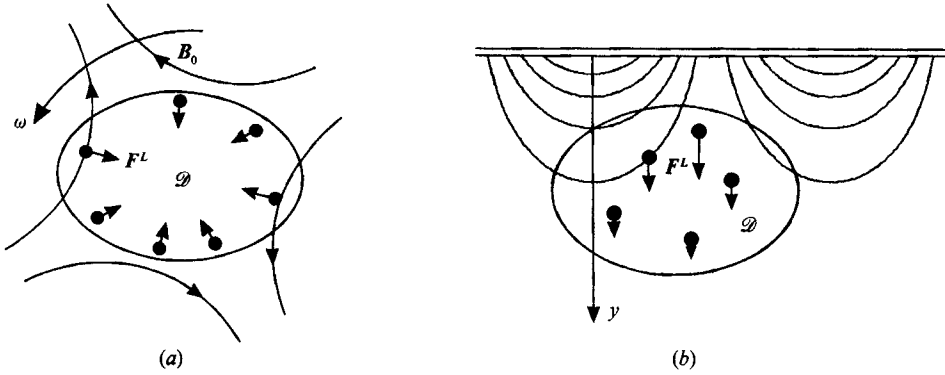

FIGURE 6. Lift force on suspended spheres: (a) a rotating field provides a force F^L towards the centre of rotation so that all spheres are driven to the interior of the domain \mathcal{D} ; (b) a single phase field of the form (2.25) produces a force field F^L in the y -direction, so that all spheres 'sediment' towards the lower boundary.

or
$$\frac{\partial c}{\partial t} + \mathbf{V} \cdot \nabla c = -c \nabla \cdot \mathbf{V} = -c \nabla \cdot \mathbf{V}^L. \tag{6.4}$$

Since $\nabla \cdot \mathbf{V}^L$ is in general non-zero, this means that c will not remain uniform even if uniform initially. In fact, from (6.1a) and (2.13),

$$\nabla \cdot \mathbf{V}^L = (a^2 \alpha^{(r)} / 6\mu_0 \rho \nu) \nabla^2 |\tilde{\mathbf{B}}_0|^2, \tag{6.5}$$

so that inhomogeneity must develop if $\nabla^2 |\tilde{\mathbf{B}}_0|^2 \neq 0$.

There is a further source of inhomogeneity arising from conditions at the boundary $\partial\mathcal{D}$ of the fluid domain, where in general $\mathbf{V} \cdot \mathbf{n} \neq 0$. If $\mathbf{V} \cdot \mathbf{n} < 0$ (where \mathbf{n} is the unit outward normal) then all suspended spheres near the boundary move into the interior of \mathcal{D} leaving a layer near $\partial\mathcal{D}$ where $c = 0$. If $\mathbf{V} \cdot \mathbf{n} > 0$ on the other hand, then spheres are driven onto the boundary just as in a process of gravitational sedimentation of particles onto a solid base. Both situations can arise, as illustrated in figure 6(a, b).

As soon as inhomogeneities of c appear in the suspension, a bulk flow will in general appear also, as may be seen by rewriting (5.4) in the form

$$\rho \frac{D\mathbf{u}}{Dt} = -\nabla p + c \tilde{\mathbf{F}}^L - \frac{1}{2} \tilde{\mathbf{G}} \wedge \nabla c + \rho \nu \nabla^2 \mathbf{u}. \tag{6.6}$$

The term $-\frac{1}{2} \tilde{\mathbf{G}} \wedge \nabla c$ is now directly responsible for driving the flow. Moreover, since

$$\nabla \wedge (c \tilde{\mathbf{F}}^L) = -\tilde{\mathbf{F}}^L \wedge \nabla c, \tag{6.7}$$

the term $c \tilde{\mathbf{F}}^L$ may also generate vorticity like the buoyancy force in a Boussinesq fluid. The former effect is present in the prototype configurations of figures 1(a, b), and will now be analysed in detail.

6.1. Rotating multipole field

Suppose that \mathcal{D} is the cylindrical domain $r < b$, and that

$$\hat{\Psi}_0 = A r^m e^{im\theta} \tag{6.8}$$

with cylindrical polar coordinates (r, θ, z) , where m is a positive integer. The case $m = 1$ gives $\mathbf{F} = 0$, $\mathbf{G} = \text{const.}$ and cannot therefore generate a bulk flow if, as we

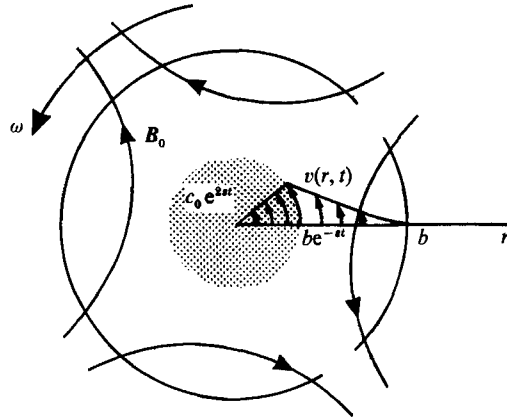

FIGURE 7. Action of a rotating field ($m = 2$) on an initially uniform suspension. The spheres are uniformly concentrated within a shrinking cylinder of radius be^{-st} , and a vortex flow with uniform-vorticity core is established.

shall suppose, the concentration c is initially uniform. We shall therefore suppose that $m > 1$. The behaviour is sufficiently well illustrated by the choice $m = 2$, for which we find from (2.13)

$$F^L = -kr\hat{e}_r, \tag{6.9}$$

where
$$k = -16\pi a^3 \mu_0^{-1} \alpha^{(r)} |A|^2 \quad (> 0). \tag{6.10}$$

The corresponding inward particle velocity is

$$V^L = -sr\hat{e}_r, \tag{6.11}$$

where $s = (6\pi\rho\nu a)^{-1}k$. The conservation equation (6.3), with effective initial condition

$$c(r, 0) = \begin{cases} c_0 & (r < b) \\ 0 & (r > b) \end{cases} \tag{6.12}$$

then has solution

$$c(r, t) = \begin{cases} c_0 e^{2st} & (r < be^{-st}) \\ 0 & (r > be^{-st}), \end{cases} \tag{6.13}$$

i.e. the suspended spheres are simply uniformly concentrated within a contracting cylinder of radius $R(t) = be^{-st}$. The situation is shown in figure 7.

The torque distribution \tilde{G} for this field is

$$\tilde{G} = G_0 r^2 \hat{e}_z, \tag{6.14}$$

where
$$G_0 = 12\mu_0^{-1} \alpha^{(t)} |A|^2. \tag{6.15}$$

Hence
$$-\frac{1}{2}\tilde{G} \wedge \nabla c = \frac{1}{2}G_0 c_0 e^{2st} \delta(r - R(t)) R^2 \hat{e}_\theta \tag{6.16}$$

so that we have an effective force in the θ -direction concentrated on $r = R(t)$.

The driven flow has the form $\mathbf{u} = (0, v(r, t), 0)$ and if we suppose that inertia forces are negligible then, from (6.6), $v(r, t)$ satisfies

$$\left(\nabla^2 - \frac{1}{r^2}\right)v = -\frac{G_0 c_0}{2\rho\nu} e^{2st} R^2 \delta(r - R(t)). \tag{6.17}$$

The solution satisfying $v(b) = 0$ and $v(0)$ finite is

$$v(r, t) = \begin{cases} \frac{G_0 c_0}{2\rho\nu} (e^{st} - 1) r & (r < R(t)) \\ \frac{G_0 c_0}{2\rho\nu} \left(1 - \frac{r^2}{b^2}\right) \frac{b^2}{r} & (r > R(t)). \end{cases} \quad (6.18)$$

The circulation at $r = R(t)$ is

$$\kappa = 2\pi Rv(R, t) = 2\pi G_0 c_0 (\rho\nu)^{-1} b(1 - e^{-st}), \quad (6.19)$$

tending to the constant value $2\pi G_0 c_0 b/\rho\nu$ as $t \rightarrow \infty$. Thus the asymptotic flow is that due to a concentrated line vortex with superposed rigid-body rotation to satisfy $v(b) = 0$.

6.2. Travelling field

Now let \mathcal{D} be the channel $|y| < b$ and let

$$\hat{\Psi}_0 = A e^{ikx} \sinh ky \quad (6.20)$$

as in §2. Then F^L is given by (2.20) so that the concentration $c(y, t)$ satisfies

$$\frac{\partial c}{\partial t} = \frac{\partial}{\partial y} (V_0 c \sinh 2ky), \quad (6.21)$$

where

$$V_0 = -\frac{1}{3}\pi a^2 |A|^2 k^3 \alpha^{(r)} (\mu_0 \rho\nu)^{-1} \quad (> 0), \quad (6.22)$$

and we require the solution satisfying the initial condition

$$c(y, 0) = \begin{cases} c_0 & (|y| < b) \\ 0 & (|y| > b). \end{cases} \quad (6.23)$$

First consider the equation

$$\frac{dY}{dt} = -V_0 \sinh 2kY \quad (6.24)$$

with initial condition $Y(0) = Y_0$. The solution is given by

$$\tanh kY(t) = e^{-2V_0 kt} \tanh(kY_0) \quad (6.25)$$

and, in particular, the layer of spheres initially at (or very near) the boundary $y = b$ moves at time t to

$$y = Y_1(t) = k^{-1} \tanh^{-1} (e^{-2V_0 kt} \tanh kb). \quad (6.26)$$

The solution of (6.21) for $|y| < Y_1(t)$ may be found by the change of variable $X = \tanh ky$, and is

$$c(y, t) = \frac{c_0 e^{2V_0 kt} \operatorname{sech}^2 ky}{1 - e^{4V_0 kt} \tanh^2 ky} \quad (|y| < Y_1(t)). \quad (6.27)$$

Also $c(y, t) = 0$ for $|y| > Y_1(t)$. There is a discontinuity of c across $y = Y_1(t)$ given by

$$\Delta c = [c] = -c_0 (e^{2V_0 kt} \cosh^2 kb - e^{-2V_0 kt} \sinh^2 kb) \quad (6.28)$$

(see figure 8).

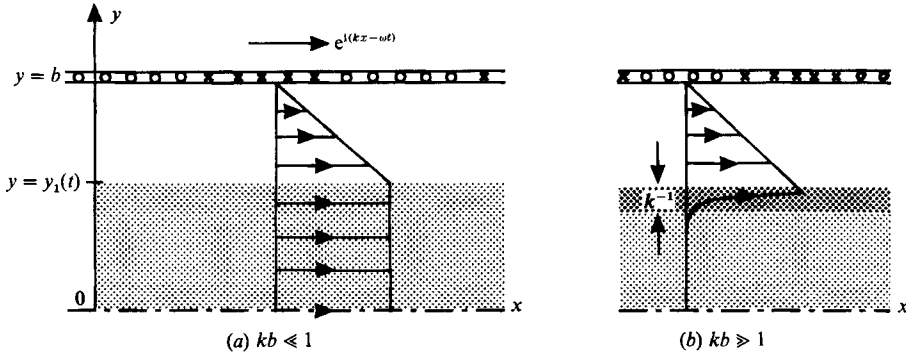

FIGURE 8. Action of a travelling field on an initially uniform suspension of spheres in the channel $|y| < b$. The situation is symmetric about $y = 0$, and only the upper half of the channel is shown. The suspension is concentrated at time t within the slab $|y| < Y_1(t)$. (a) $kb \leq 1$: a piecewise-constant vorticity distribution is established. (b) $kb \geq 1$: a δ -function in concentration appears on $y = Y_1(t)$, and this generates an associated vortex sheet in the bulk flow.

If $kb \leq 1$, the situation is very similar to that considered in the previous example. In this case, $c(y, t) \sim c_0 e^{2V_0 kt}$ for $|y| < Y_1(t) \sim b e^{-2V_0 kt}$, so that the velocity $\mathbf{u} = u(y, t) \hat{\mathbf{e}}_x$ is driven by the discontinuities of c across $y = \pm Y_1(t)$. Neglecting inertia, and with $G'_0 = \mu_0^{-1} 2\pi a^3 |A|^2 k^2 \alpha^{(1)}$, we find

$$u(y, t) = \begin{cases} \frac{G'_0 c_0 kb^2}{\nu\rho} \left(1 - \frac{|y|}{b}\right) & (|y| > Y_1(t)) \\ \frac{G'_0 c_0 kb^2}{\nu\rho} (1 - e^{-2V_0 kt}) & (|y| < Y_1(t)), \end{cases} \quad (6.29)$$

so that, as $t \rightarrow \infty$, a vorticity discontinuity

$$[\omega_z] = 2G'_0 c_0 kb / \nu\rho \quad (6.30)$$

tends to form on the plane $y = 0$ towards which the suspended spheres are driven.

If $kb \geq 1$, the situation is more complicated because the bulk velocity is driven by the variation of concentration for $|y| < Y_1(t)$ as well as by the jumps in c across $y = \pm Y_1(t)$. The total variation of concentration however is confined to layers of thickness k^{-1} on $y = \pm Y_1(t)$, and the conductivity distribution may be approximated by

$$c(y, t) = c_0 [1 - H(y - Y_1) + (b - Y_1) \delta(y - Y_1)], \quad (6.31)$$

where $H(x)$ is the Heaviside function. A simple calculation then gives

$$u(y, t) = \begin{cases} \frac{G'_0 c_0 b}{2\rho\nu} \sinh 2kY_1 \left(1 - \frac{|y|}{b}\right) & (|y| > Y_1) \\ 0 & (|y| < Y_1), \end{cases} \quad (6.32)$$

so that now a vortex sheet appears on $y = Y_1(t)$. Of course in reality, this vortex sheet is 'smoothed' through the layer of thickness k^{-1} .

The two situations are sketched in figure 8 (a, b).

7. Conclusions

We have shown that a single conducting particle placed in a time-periodic magnetic field of the form $\text{Re}(\hat{\mathbf{B}}_0(\mathbf{x})e^{-i\omega t})$ in general experiences a force \mathbf{F} and a torque \mathbf{G} , which are functions of the position \mathbf{x} of the centre of volume of the particle. The force \mathbf{F} has a natural decomposition $\mathbf{F} = \mathbf{F}^L + \mathbf{F}^D$, where $\nabla \wedge \mathbf{F}^L = 0$, $\nabla \cdot \mathbf{F}^D = 0$; and if the relationship between the induced dipole moment $\hat{\boldsymbol{\mu}}$ and $\hat{\mathbf{B}}$ is isotropic (as for a spherical particle) then there is a simple relationship between \mathbf{F}^D and \mathbf{G} , namely

$$\mathbf{F}^D + \frac{1}{2}\nabla \wedge \mathbf{G} = 0. \quad (7.1)$$

If two or more particles are suspended in a viscous fluid and subjected to such a field, then each particle will move in response to the force and torque acting on it and will at the same time be convected by the Stokes flow (a superposition of Stokeslets and couplets) induced by the other particles. Examples of such interactions are given in §§3 and 4 for the particular case of a uniform rotating field, in which case there is a compelling analogy with the classical problem of interaction of point vortices. In particular, the motion of four or more spheres must in general exhibit chaos.

When a suspension of particles is considered, it is shown that the condition (7.1) implies that in any region in which the concentration c is uniform there is no net local force to drive a bulk flow. Bulk flow can be driven only through interaction of the body torque distribution $\tilde{\mathbf{G}}$ with the spatial gradient of c through a term $-\frac{1}{2}\tilde{\mathbf{G}} \wedge \nabla c$ in the bulk equation of motion. Inhomogeneities of c are generated by the 'levitation' force \mathbf{F}^L through a process analogous to sedimentation in a gravitational field. Two examples of flows driven by such a combination of effects are analysed in §6.

An initial aim of this investigation was to determine whether a homogeneous suspension could be set in rotation by a rotating magnetic field, as happens for a homogeneous fluid conductor (Moffatt 1965). The results of §§5, 6 show that a uniform rotating field acting on a homogeneous suspension will generate no bulk flow; but that rotation can be induced by a rotating multipole field; and similarly that bulk transport can be generated by a travelling field, although only with an accompanying development of strong inhomogeneity in the suspension.

If the constituent particles of the suspension do not have spherical, or equivalent, symmetry, so that the relation between $\hat{\boldsymbol{\mu}}$ and $\hat{\mathbf{B}}_0$, although linear, is non-isotropic, then (7.1) no longer holds, and more subtle effects may be anticipated. For example, if the particles are needle-shaped, then as a particle rotates under the action of a torque \mathbf{G} , the induction tensor α_{ij} in the relationship between $\hat{\mu}_i$ and \hat{B}_{0j} will become time-dependent and the force and torque on the particle will change accordingly. Determination of the motion of such a particle is then quite a complex problem; but this is just a preliminary to understanding the behaviour of a suspension of such particles.

There are certain obvious points of contact in all this with the theory of ferromagnetic suspensions (Rosensweig 1985) in which microscopic dipoles respond to the direction and strength of an applied magnetic field, whether steady or unsteady. The novel features in a suspension of *conducting* particles are that the dipole moments are themselves induced by time-variation of the applied field and that the relation between $\hat{\boldsymbol{\mu}}$ and $\hat{\mathbf{B}}_0$ is then linear. These features lead to a class of problems that have some fundamental interest, and that may have some practical application in relation to metallurgical processing.

Appendix A. Justification of (2.10)

Choosing origin at the centre of volume of the body, we may expand the unperturbed field $\hat{\Psi}_0(\mathbf{x})$ in Taylor series

$$\hat{\Psi}_0(\mathbf{x}) - \hat{\Psi}_0(0) = b_i x_i + \frac{1}{2} c_{ij} x_i x_j + \frac{1}{3!} d_{ijk} x_i x_j x_k + \dots, \quad (\text{A } 1)$$

the corresponding expansion for $\hat{\mathbf{B}}_0(\mathbf{x})$ being

$$\hat{\mathbf{B}}_{0i}(\mathbf{x}) = b_i + c_{ij} x_j + \frac{1}{2} d_{ijk} x_j x_k + \dots \quad (\text{A } 2)$$

Here,

$$b_i = \hat{\mathbf{B}}_{0i}(0), \quad c_{ij} = (\partial \hat{\mathbf{B}}_{0i} / \partial x_j)_{\mathbf{x}=0}, \text{ etc.} \quad (\text{A } 3)$$

and obviously

$$c_{ij} = c_{ji}, \quad c_{ii} = 0, \quad (\text{A } 4)$$

with similar constraints on higher-order coefficients.

The induced currents in the body perturb this external field to the form

$$\hat{\Psi} = \hat{\Psi}_0 + \hat{\Psi}_1, \quad (\text{A } 5)$$

where

$$\left(\frac{4\pi}{\mu_0}\right) \hat{\Psi}_1 = (\hat{\boldsymbol{\mu}} \cdot \nabla) \frac{1}{r} + \frac{1}{2} \hat{\mu}_{jk} \frac{\partial^2}{\partial x_j \partial x_k} \left(\frac{1}{r}\right) + \dots, \quad (\text{A } 6)$$

i.e. a sum of dipole, quadrupole and higher-order ingredients. The field outside the body is then $\hat{\mathbf{B}} = \hat{\mathbf{B}}_0 + \hat{\mathbf{B}}_1$ where

$$\left(\frac{4\pi}{\mu_0}\right) \hat{\mathbf{B}}_{1i}(\mathbf{x}) = \hat{\mu}_j \frac{\partial^2}{\partial x_i \partial x_j} \left(\frac{1}{r}\right) + \frac{1}{2} \hat{\mu}_{jk} \frac{\partial^3}{\partial x_i \partial x_j \partial x_k} \left(\frac{1}{r}\right) + \dots \quad (\text{A } 7)$$

The mean Lorentz force distribution in the body is

$$f_i = \frac{1}{2} \text{Re} (\mathbf{j} \wedge \hat{\mathbf{B}}^*)_{i} = \frac{1}{2} \frac{\partial}{\partial x_j} T_{ij}, \quad (\text{A } 8)$$

where

$$\mu_0 T_{ij} = \text{Re} (\hat{\mathbf{B}}_i \hat{\mathbf{B}}_j^* - \frac{1}{2} |\hat{\mathbf{B}}|^2 \delta_{ij}), \quad (\text{A } 9)$$

the Maxwell stress tensor. Since $\mathbf{J} = 0$ outside the body, the total force \mathbf{F} and couple \mathbf{G} may be expressed as surface integrals over a sphere A of radius R containing the body:

$$\mathbf{F}_i = \int_A \mathbf{f}_i dV = \frac{1}{2} \int_A T_{ij} n_j dS, \quad (\text{A } 10)$$

$$G_i = \int (\mathbf{x} \wedge \mathbf{f})_i dV = \frac{1}{2} \int_A \epsilon_{ijk} x_j T_{ki} n_l dS. \quad (\text{A } 11)$$

These expressions must obviously be independent of R ; hence the only part of T_{ij} contributing to (A 10) must be that part ($T_{ij}^{(F)}$ say) proportional to r^{-2} , and the only part contributing to (A 11) must be that part ($T_{ij}^{(G)}$) proportional to r^{-3} .

It is easy to see that the leading-order contribution to $T_{ij}^{(F)}$ comes from interaction of the fields $c_{ij} x_j$ and $\hat{\mu}_j (\partial^2 / \partial x_i \partial x_j) (1/r)$, and the leading-order contribution to $T_{ij}^{(G)}$ comes from interaction between B_i and $\hat{\mu}_j (\partial^2 / \partial x_i \partial x_j) (1/r)$; explicitly, at leading order,

$$4\pi T_{ij}^{(F)} = \text{Re} \left(c_{jm}^* x_m \hat{\mu}_k \frac{\partial^2}{\partial x_i \partial x_k} \left(\frac{1}{r}\right) + c_{im}^* x_m \hat{\mu}_k \frac{\partial^2}{\partial x_j \partial x_k} \left(\frac{1}{r}\right) - c_{km}^* x_m \hat{\mu}_l \frac{\partial^2}{\partial x_k \partial x_l} \left(\frac{1}{r}\right) \delta_{ij} \right) \quad (\text{A } 12)$$

and

$$4\pi T_{ij}^{(G)} = \text{Re} \left(b_i^* \hat{\mu}_k \frac{\partial^2}{\partial x_j \partial x_k} \left(\frac{1}{r} \right) + b_j^* \hat{\mu}_k \frac{\partial^2}{\partial x_i \partial x_k} \left(\frac{1}{r} \right) - b_k^* \hat{\mu}_i \frac{\partial^2}{\partial x_k \partial x_i} \left(\frac{1}{r} \right) \delta_{ij} \right). \quad (\text{A } 13)$$

Hence by substitution in (A 10) and (A 11) respectively, \mathbf{F} and \mathbf{G} may be calculated. With repeated use of the isotropic integral

$$\int_{r-R} x_j x_m \frac{\partial^2}{\partial x_i \partial x_k} \left(\frac{1}{r} \right) dA = \frac{4\pi}{3} r (6\delta_{ik} \delta_{jm} - \delta_{ij} \delta_{km} - \delta_{im} \delta_{jk}), \quad (\text{A } 14)$$

we find

$$F_i = \frac{1}{2} \text{Re} (\hat{\mu}_j c_{ij}^*), \quad (\text{A } 15)$$

$$G_i = \frac{1}{2} \text{Re} (\epsilon_{ijk} \hat{\mu}_j b_k^*), \quad (\text{A } 16)$$

which are, as expected, identical with (2.10) (using (A 3)).

This is of course reassuring, but it has the added bonus that higher-order terms in $(a/L)^2$ may be obtained if required. The correction to F_i , of order $(a/L)^2$, involves the product $\hat{\mu}_{jk} d_{ijk}^*$, or equivalently a term of the form

$$F_i^{(\text{corr.})} = \frac{1}{2} \text{Re} \left(\hat{\mu}_{jk} \frac{\partial^2 \hat{B}_{0i}^*}{\partial x_j \partial x_k} \right). \quad (\text{A } 17)$$

Similarly, the correction to G_i at order $(a/L)^2$ is

$$G_i^{(\text{corr.})} = \frac{1}{2} \text{Re} \left(\epsilon_{ijk} \hat{\mu}_{jm} \frac{\partial B_{0k}^*}{\partial x_m} \right). \quad (\text{A } 18)$$

Appendix B. Determination of $\alpha(\lambda)$ for a spherical particle

Since α is independent of $\hat{\mathbf{B}}_0(\mathbf{x})$, we may assume that $\hat{\mathbf{B}}_0$ is uniform and real, so that the applied field is $\hat{\mathbf{B}}_0 \cos \omega t$. For $r > a$ (where a is the radius of the sphere), the modified magnetic potential is then

$$\Psi(\mathbf{x}) = b_i x_i \left(1 - \frac{\alpha a^3}{r^3} \right), \quad (\text{B } 1)$$

where $\mathbf{b} = \hat{\mathbf{B}}_0$, and α is as defined in (2.9).

The induction problem is most easily solved in terms of the scalar field $P(\mathbf{x})$ defined by

$$\mathbf{B} = \nabla \wedge \nabla \wedge (\mathbf{x}P(\mathbf{x})), \quad (\text{B } 2)$$

which, for $r > a$, is related to Ψ by

$$\Psi = P + (\mathbf{x} \cdot \nabla)P = \frac{\partial}{\partial r}(rP). \quad (\text{B } 3)$$

Hence,

$$P = (\mathbf{b} \cdot \mathbf{x}) \left(\frac{1}{2} + \alpha \left(\frac{a}{r} \right)^3 \right) \quad (r > a). \quad (\text{B } 4)$$

Unlike Ψ , P is defined also for $r < a$, and there satisfies

$$\nabla^2 P = -i\omega\mu_0 \sigma P \quad (r < a). \quad (\text{B } 5)$$

Moreover, continuity of \mathbf{B} across $r = a$ is satisfied provided

$$[P] = [\partial P / \partial r] = 0 \quad \text{across} \quad r = a. \quad (\text{B } 6)$$

The solution of (B 5) regular at $r = 0$ is

$$P = \beta \left(\frac{a}{r} \right) (\mathbf{b} \cdot \mathbf{x}) j_1 \left(\frac{\eta r}{a} \right) \quad (r < a), \quad (\text{B } 7)$$

where

$$\eta = (1 + i) \lambda \quad (\text{B } 8)$$

and

$$j_1(z) = \frac{\sin z}{z^2} - \frac{\cos z}{z}, \quad (\text{B } 9)$$

the spherical Bessel function of order one. The continuity conditions (B 6) now give

$$\beta j_1(\eta) = \frac{1}{2} + \alpha, \quad \beta \eta j_1'(\eta) = \frac{1}{2} - 2\alpha, \quad (\text{B } 10)$$

so that, after some simplification,

$$\alpha = \frac{-\eta j_1' + j_1}{2(\eta j_1' + 2j_1)} = -\frac{1}{2} \left[\frac{3 \cot \eta}{\eta} - \frac{3}{\eta^2} + 1 \right], \quad (\text{B } 11)$$

which together with (B 8), determines $\alpha(\lambda) = \alpha^{(r)}(\lambda) + i\alpha^{(i)}(\lambda)$. The real and imaginary parts of (B 11) give the results (2.29) and (2.30).

The solution as found here was first described by Lamb (1883) as part of a general study of electromagnetic induction in a spherical conductor.

REFERENCES

- AREF, H. 1984 Stirring by chaotic advection. *J. Fluid Mech.* **143**, 1–21.
- AREF, H. & POMPHREY, N. 1982 Integrable and chaotic motions of four vortices I. The case of identical vortices. *Proc. R. Soc. Lond. A* **380**, 359–387.
- BATCHELOR, G. K. 1970 The stress system in a suspension of force-free particles. *J. Fluid Mech.* **41**, 545–570.
- BRANCHER, J.-P. 1988 Comportement d'un ferrofluide dans un champ magnétique tournant et application. *J. Méc. Theor. Appl.* **7**, 329–350.
- BRAUNBECK, W. 1932 Eine neue Methode elektrodenloser Leitfähigkeitsmessung. *Z. Phys.* **73**, 312–334.
- JANSONS, K. M. 1983 Determination of the constitutive equations for a magnetic fluid. *J. Fluid Mech.* **137**, 187–216.
- LAMB, H. 1883 On electrical motions in a spherical conductor. *Phil. Trans. R. Soc. Lond.* **174**, 519–549.
- LANDAU, L. D. & LIFTSHITZ, E. M. 1959 *Fluid Mechanics*, Pergamon.
- MOFFATT, H. K. 1965 On fluid flow induced by a rotating magnetic field. *J. Fluid Mech.* **22**, 521–528 (and Corrigendum **58** (1973) 823).
- MOFFATT, H. K. 1980 Rotation of a liquid metal under the action of a rotating magnetic field. In *MHD Flows and Turbulence, II* (ed. H. Branover & A. Yakhot), pp. 45–62. Jerusalem: Israel University Press.
- ROSENSWEIG, R. E. 1985 *Ferrohydrodynamics*, Cambridge University Press.