

Mathematical Tripos Part IB

Electromagnetism

Harvey Reall

Introduction

From a long view of the history of mankind, seen from, say, ten thousand years from now, there can be little doubt that the most significant event of the 19th century will be judged as Maxwell's discovery of the laws of electrodynamics. (Richard Feynman)

The phenomenon of magnetism has been known for a long time. In ancient times, people discovered that certain rocks had magnetic properties. Later these were used to build compass needles for navigation. The phenomenon of electricity, in the form of lightning was familiar to early humans. Static electricity was discovered in antiquity: after rubbing an amber rod with a cloth one could use it to pick up small items such as leaves. In the 19th century, scientists discovered how to control electricity and build batteries that caused electric currents to flow. It was realized that there is an intimate relation between electricity and magnetism: electric currents have magnetic properties, and moving magnets can cause currents to flow. So electricity and magnetism are different aspects of one subject, called electromagnetism.

In 1861, James Clerk Maxwell discovered a set of equations that explained all known electromagnetic phenomena. Furthermore, the theory explained that light is an electromagnetic wave, and predicted the existence of new kinds of electromagnetic wave (radio, infrared, ultraviolet etc) that were subsequently discovered. Maxwell's theory (along with quantum mechanics) is the foundation of modern electronics and communications technology. This theory also played a crucial role in the discovery of special relativity.

At the fundamental level, there are four different types of interaction in Nature. These are: electromagnetism, gravity, the weak nuclear force (responsible for certain radioactive decays) and the strong nuclear force (which holds atomic nuclei together). Everything else is a consequence of these basic interactions. Our best theoretical description of electromagnetism is still provided by Maxwell's theory. Maxwell's theory is an example of a *field theory*, in which the basic entities are fields rather than particles. Our theories of the other fundamental interactions are also field theories. So studying Maxwell's theory is an introduction to the language of modern physics.

1 Fundamentals

1.1 Electric charge

Experiments in the 1700s discovered that all bodies possess a property called *electric charge* such that: for two bodies at rest and separated by a distance large compared to their sizes, there is a force between them, directed along the line between them,

with strength proportional to the charge of each body and inversely proportional to the square of the distance between them. Mathematically, the force on body 1 due to body 2 is given by *Coulomb's law*

$$\mathbf{F} = \frac{Q_1 Q_2 (\mathbf{x}_1 - \mathbf{x}_2)}{4\pi\epsilon_0 |\mathbf{x}_1 - \mathbf{x}_2|^3} \quad (1.1)$$

where \mathbf{x}_i are the positions of the bodies and Q_i are their electric charges. Electric charge is measured in units called *Coulombs* (C). ϵ_0 is a constant called the *permittivity of free space*, with value

$$\epsilon_0 = 8.85418782 \times 10^{-12} \text{m}^{-3} \text{kg}^{-1} \text{s}^2 \text{C}^2 \quad (1.2)$$

Experimentally, it is found that electric charge can be either positive or negative. If the two bodies have charges of the same sign then the force is repulsive. If they have charges of opposite sign then the force is attractive.

There is a close similarity between Coulomb's law and Newton's law of gravity. Both are inverse square laws. Charge plays a role analogous to mass in gravity. But there are several important differences. First, charge can be either positive or negative whereas mass is always positive. Second, like charges repel whereas gravity is always attractive. Third, as we'll discuss below, the Coulomb force is much stronger than the gravitational force.

Another experimental observation is that electric charge is *conserved*: it can be transferred from one body to another but the total amount of charge remains the same. For example if one starts with a cloth and a nylon rod, both with zero charge, and rubs the rod with the cloth, then the rod and cloth will acquire equal and opposite electric charge.

Microscopically, matter is made of atoms, which are composed of a nucleus of protons and neutrons surrounded by orbiting electrons. Particle physics has uncovered many more exotic particles. It turns out that every¹ known particle has an electric charge that is a multiple of a positive fundamental unit e (not to be confused with the base of natural logarithms!). The Coulomb is defined by stating that e has the *exact* value²

$$e = 1.602176634 \times 10^{-19} \text{C} \quad (1.3)$$

¹Actually, protons and neutrons are made of more fundamental particles called quarks, whose charges are multiples of $e/3$. But quarks cannot exist individually, only in bound states such as the proton or neutron for which the total charge is a multiple of e .

²This definition was adopted on 20 May 2019. Before this date, the Coulomb was defined in terms of the Amp: see below.

A proton has charge $+e$, an electron has charge $-e$ and a neutron has zero charge. Atoms are electrically neutral (i.e. they have zero charge), so an atom with Z protons will also have Z electrons. This means that, under normal circumstances, matter is electrically neutral, which is why we don't notice the Coulomb force all the time. But if we rub two objects together, then it is easy to transfer a few electrons from one object to the other. Then the object gaining the electrons has charge $-Ne$ and the object that has lost the electrons has charge $+Ne$ where N is the number of electrons transferred.

At this level it appears that conservation of charge might just be a consequence of conservation of electrons and protons. But this is incorrect because electrons and protons are not always conserved. For example in radioactive β decay, a neutron (charge 0) decays into a proton (charge $+e$), an electron (charge $-e$) and a particle called an *antineutrino* (charge 0). So the number of protons and electrons changes but the total charge is conserved.

Let's now compare the strength of the Coulomb force between two protons with the gravitational force between the same particles. The result is

$$\frac{F_{\text{Coulomb}}}{F_{\text{grav}}} = \frac{e^2}{4\pi\epsilon_0 G m_p^2} \quad (1.4)$$

where m_p is the mass of the proton and G is Newton's gravitational constant. Plugging in numbers, the RHS evaluates to 10^{36} . The ratio is about 10^{42} for a pair of electrons. Thus the Coulomb force between two particles is *huge* compared to the gravitational force between them. The reason that gravity appears more prominent in our everyday experience is that we are experiencing the gravitational force of the entire Earth. But even then it is easy to overcome this force e.g. I can easily jump up and down. Gravity is a very weak force, and only becomes important for very large objects.

1.2 Charge and current density

Charge is carried by discrete particles. However, when we are discussing *macroscopic* physics, i.e., physics on scales large compared to the size of atoms, it is very convenient to approximate charge as a continuous distribution. The *charge density* $\rho(t, \mathbf{x})$ is a scalar field defined so that the total charge contained in a small volume dV centered on \mathbf{x} is $\rho(t, \mathbf{x})dV$. The *current density* $\mathbf{J}(t, \mathbf{x})$ is a vector field defined by the statement that the charge crossing a small surface element $d\mathbf{S}$ in time dt is $\mathbf{J} \cdot d\mathbf{S}dt$.

Example. Consider a *plasma* (a gas of charged particles) containing N types of charged particle. Let $n_i(t, \mathbf{x})$ be the *number density* of particles of type i , i.e., there are $n_i dV$ particles of type i in a volume dV . Let q_i be the charge of each particle of type i and assume that all particles of type i in volume dV have the same velocity $\mathbf{v}_i(t, \mathbf{x})$. Then the total charge in dV is $\sum_{i=1}^N q_i n_i dV$ so $\rho = \sum_i q_i n_i$. In time dt , all particles of

type i within a volume $(\mathbf{v}_i dt) \cdot d\mathbf{S}$ cross $d\mathbf{S}$, and these particles carry charge $q_i n_i \mathbf{v}_i \cdot d\mathbf{S} dt$ hence, summing over all types of particle, the current density is $\mathbf{J} = \sum_i q_i n_i \mathbf{v}_i$.

If we have a finite surface S then the charge per unit time crossing S is called the electric *current* across S

$$I = \int_S \mathbf{J} \cdot d\mathbf{S} \quad (1.5)$$

This depends on the choice of normal for S . If S is a closed surface then we always choose the outward normal. Current is measured in units called *Ampères* or Amps, with symbol A. An Amp is one Coulomb per second: $1\text{A} = 1\text{Cs}^{-1}$.

Consider a fixed (time-independent) closed volume V with boundary S . The total electric charge in V is

$$Q(t) = \int_V \rho(t, \mathbf{x}) dV \quad (1.6)$$

If the charge distribution changes with time then charge may cross the surface S . The total charge crossing S in time dt is $I dt$. By charge conservation, this must equal the decrease in $Q(t)$ over time dt , i.e., it must equal $-(dQ/dt)dt$. Hence we have $dQ/dt = -I$, i.e.,

$$\frac{dQ}{dt} = - \int_S \mathbf{J} \cdot d\mathbf{S} \quad (1.7)$$

This is the mathematical statement of charge conservation in integral form. From (1.6) we have (using the time-independence of V)

$$\frac{dQ}{dt} = \int_V \frac{\partial \rho}{\partial t} dV \quad (1.8)$$

and so, using the divergence theorem, we obtain

$$\int_V \left(\frac{\partial \rho}{\partial t} + \nabla \cdot \mathbf{J} \right) dV = 0 \quad (1.9)$$

Since this must hold for *any* volume V we deduce that

$$\frac{\partial \rho}{\partial t} + \nabla \cdot \mathbf{J} = 0 \quad (1.10)$$

This is the statement of charge conservation in differential form.

Although we are primarily interested in continuous charge distributions, it is also possible to describe charged particles in the above notation. The charge and current densities corresponding to a single particle of charge³ q and position $\mathbf{x}_1(t)$ are⁴

$$\rho(t, \mathbf{x}) = q \delta^{(3)}(\mathbf{x} - \mathbf{x}_1(t)) \quad \mathbf{J}(t, \mathbf{x}) = q \dot{\mathbf{x}}_1(t) \delta^{(3)}(\mathbf{x} - \mathbf{x}_1(t)) \quad (1.11)$$

³I'll use Q to denote a macroscopic (large) amount of charge and q a microscopic amount.

⁴Recall that $\delta^{(3)}(\mathbf{x}) = \delta(x)\delta(y)\delta(z)$ and $\delta^{(3)}(\mathbf{x} - \mathbf{x}')$ has the property that its integral w.r.t. \mathbf{x} over a region V is 1 if \mathbf{x}' lies inside V and 0 if \mathbf{x}' lies outside V .

These satisfy the conservation law (1.10) (exercise). If we have N particles with charges q_i and positions $\mathbf{x}_i(t)$ then

$$\rho(t, \mathbf{x}) = \sum_{i=1}^N q_i \delta^{(3)}(\mathbf{x} - \mathbf{x}_i(t)) \quad \mathbf{J}(t, \mathbf{x}) = \sum_{i=1}^N q_i \dot{\mathbf{x}}_i(t) \delta^{(3)}(\mathbf{x} - \mathbf{x}_i(t)) \quad (1.12)$$

1.3 Lorentz force law

Let's now consider the effect of some (possibly time-dependent) distribution of charge and current on the motion of a charged body. We don't want the body itself to influence the distribution of charge and current and so we consider a body whose charge is very small. We will also assume that the size of the body is small so that we can view it as a pointlike object. A body with these properties is called a *test body*. (It is really an idealization in which we consider a sequence of bodies with smaller and smaller charge and size.) It is found experimentally that a test body with charge q , position \mathbf{x} , and velocity \mathbf{v} experiences a force given by the *Lorentz force law*

$$\mathbf{F} = q [\mathbf{E}(t, \mathbf{x}) + \mathbf{v} \times \mathbf{B}(t, \mathbf{x})] \quad (1.13)$$

here $\mathbf{E}(t, \mathbf{x})$ is a vector field called the *electric field* and $\mathbf{B}(t, \mathbf{x})$ is a vector field called the *magnetic field*. More properly, \mathbf{B} is a pseudovector field because the definition of the cross product involves ϵ_{ijk} , so for $\mathbf{v} \times \mathbf{B}$ to be a vector it is necessary that \mathbf{B} is a pseudovector.

As an example, consider the Coulomb force (1.1) exerted on a static test body by another static body of charge Q and position \mathbf{x}_0 . From the above formula we can read off the electric field

$$\mathbf{E}(\mathbf{x}) = \frac{Q}{4\pi\epsilon_0} \frac{\mathbf{x} - \mathbf{x}_0}{|\mathbf{x} - \mathbf{x}_0|^3} \quad (1.14)$$

For positive Q this points radially away from the body. For a system of N static charges Q_i with positions \mathbf{x}_i the electric field is

$$\mathbf{E}(\mathbf{x}) = \sum_{i=1}^N \frac{Q_i}{4\pi\epsilon_0} \frac{\mathbf{x} - \mathbf{x}_i}{|\mathbf{x} - \mathbf{x}_i|^3} \quad (1.15)$$

The second term in the Lorentz force law is non-zero only for a moving test body. It describes a force perpendicular to the direction of motion of the body. For example, if \mathbf{B} is constant then this will cause a charged test body to follow a helical trajectory: see examples sheet 1.

The Lorentz force law represents an important shift in our point of view. Coulomb's law involves action at a distance: a particle at \mathbf{x}_1 responds directly to a particle at

\mathbf{x}_2 . But the Lorentz force law is *local*: a test body at \mathbf{x}_1 responds to the electric and magnetic *fields* at the same point \mathbf{x}_1 . The idea is that these fields are themselves created by the charge/current distribution. But they are not just a mathematical device, they have real physical existence.⁵ As we will see, the electric and magnetic fields can carry energy and momentum, and exhibit wavelike behaviour.

To visualize the electric field we can plot electric field lines. The electric field lines at time t are defined as curves $\mathbf{x}(\lambda)$ which are tangent to \mathbf{E} , i.e., they satisfy $d\mathbf{x}/d\lambda = \mathbf{E}(t, \mathbf{x})$. Magnetic field lines are defined similarly. For example, the electric field lines defined by (1.14) point radially away from (if $Q > 0$) the point \mathbf{x}_0 .

The Lorentz force law gives us the force on a test body. We can determine the force on any other body by viewing it as a collection of particles and treating each particle as a test body. If the body contains N particles then total force on them is

$$\begin{aligned} \mathbf{F}(t) &= \sum_{i=1}^N q_i [\mathbf{E}(t, \mathbf{x}_i(t)) + \dot{\mathbf{x}}_i(t) \times \mathbf{B}(t, \mathbf{x}_i(t))] \\ &= \sum_{i=1}^N \int q_i \delta^{(3)}(\mathbf{x} - \mathbf{x}_i(t)) [\mathbf{E}(t, \mathbf{x}) + \dot{\mathbf{x}}_i(t) \times \mathbf{E}(t, \mathbf{x})] dV \\ &= \int_{V(t)} [\rho(t, \mathbf{x})\mathbf{E}(t, \mathbf{x}) + \mathbf{J}(t, \mathbf{x}) \times \mathbf{B}(t, \mathbf{x})] dV \end{aligned} \quad (1.16)$$

where $V(t)$ is the region of space occupied by the body at time t . In the second equality we're just using the definition of the delta function, and in the third equality we've used (1.12). This gives us the total force on a body with charge density ρ and current density \mathbf{J} . Similarly the total torque on the body is

$$\boldsymbol{\tau}(t) = \int_{V(t)} \mathbf{x} \times [\rho(t, \mathbf{x})\mathbf{E}(t, \mathbf{x}) + \mathbf{J}(t, \mathbf{x}) \times \mathbf{B}(t, \mathbf{x})] dV \quad (1.17)$$

1.4 Maxwell's equations

In 1861, James Clerk Maxwell (Fig. 1) wrote down a set of equations relating \mathbf{E} and \mathbf{B} to ρ and \mathbf{J} . In modern notation, Maxwell's equations are:⁶

$$\nabla \cdot \mathbf{E} = \frac{\rho}{\epsilon_0} \quad (\text{M1})$$

$$\nabla \cdot \mathbf{B} = 0 \quad (\text{M2})$$

$$\nabla \times \mathbf{E} = -\frac{\partial \mathbf{B}}{\partial t} \quad (\text{M3})$$

⁵The field concept is due to Faraday.

⁶The equations were first written in this form by Heaviside in 1884.



Figure 1. Statue of James Clerk Maxwell in Edinburgh. The birds have not been kind to him.

$$\nabla \times \mathbf{B} = \mu_0 \mathbf{J} + \frac{1}{c^2} \frac{\partial \mathbf{E}}{\partial t} \quad (\text{M4})$$

where μ_0 and c are positive constants. μ_0 is called the *permeability of the vacuum* and has the experimentally determined value

$$\mu_0 = 1.25663706212 \times 10^{-6} \text{NA}^{-2} \quad (1.18)$$

To a very good approximation we have⁷

$$\mu_0 \approx 4\pi \times 10^{-7} \text{NA}^{-2} = 1.2566370614 \dots \times 10^{-6} \text{NA}^{-2} \quad (1.19)$$

The constant c has dimensions of velocity. We'll see below that consistency of Maxwell's equations with charge conservation requires that

$$c^2 = \frac{1}{\mu_0 \epsilon_0} \quad (1.20)$$

⁷Before 20 May 2019, the Amp was defined by the statement that $\mu_0 = 4\pi \times 10^{-7} \text{NA}^{-2}$ holds *exactly*. The Coulomb was then defined as $1\text{C} = 1\text{As}$ and e was determined experimentally.

Plugging in the values of μ_0 and ϵ_0 one finds⁸

$$c = 2.99792458 \times 10^8 \text{ ms}^{-1} \quad (1.21)$$

which is the speed of light!

In the rest of this course we will be discussing the consequences of these equations. Let's start with a few observations.

Equation (M1) shows that electric charge always gives rise to an electric field. On the other hand, equation (M2) shows that there is no corresponding notion of magnetic charge.⁹ Equation (M3) implies that a time-dependent magnetic field will produce an electric field. Finally, equation (M4) shows that an electric current will produce a magnetic field. Equation (M4) also predicts that a time-varying electric field can produce a magnetic field in the same way as an electric current. This was a completely new physical effect first predicted by Maxwell's theory. The final term in (M4) is sometimes called the *displacement current*.

Maxwell's equations show that, in a time-dependent situation, the electric and magnetic fields are intimately related. When we discuss special relativity, we will see that \mathbf{E} and \mathbf{B} are mixed up by Lorentz transformations, and are really just different components of a tensor in four-dimensional spacetime. So we will sometimes talk about *the electromagnetic field* rather than “the electric and magnetic fields”.

Note that Maxwell's equations are *linear* in \mathbf{E} and \mathbf{B} . Hence they obey the *superposition principle*: if we superpose two different charge/current distributions then the resulting \mathbf{E} field is obtained by adding the \mathbf{E} fields of the two distributions, and similarly for the \mathbf{B} field.

To explain (1.20), take a time derivative of (M1) to obtain

$$0 = \frac{\partial}{\partial t} \left(\nabla \cdot \mathbf{E} - \frac{\rho}{\epsilon_0} \right) = \nabla \cdot \frac{\partial \mathbf{E}}{\partial t} - \frac{1}{\epsilon_0} \frac{\partial \rho}{\partial t} = -c^2 \mu_0 \nabla \cdot \mathbf{J} - \frac{1}{\epsilon_0} \frac{\partial \rho}{\partial t} \quad (1.22)$$

where in the final step we used (M4) and the fact that the divergence of a curl vanishes. We see that Maxwell's equations are consistent with the charge conservation equation (1.10) iff (1.20) is satisfied. Note that the presence of the displacement current in (M4) is crucial for this argument to work.¹⁰

⁸Nowadays we define the metre by saying that (1.21) is exact and then use (1.20) to define ϵ_0 .

⁹Some Grand Unified Theories predict the existence of *magnetic monopoles*: magnetically charged particles. They also tell us how to extend Maxwell's equations to describe such objects. However, a magnetic monopole has never been observed.

¹⁰Although it was not this argument that led Maxwell to introduce the displacement current. Instead he was motivated by a mechanical model which is now obsolete.

At first it is surprising to see c appearing in Maxwell's equations. What do \mathbf{E} and \mathbf{B} have to do with light? To answer this, let's show that \mathbf{E} and \mathbf{B} both satisfy the wave equation. Taking a curl of (M3) gives

$$\nabla \times (\nabla \times \mathbf{E}) = -\frac{\partial}{\partial t} \nabla \times \mathbf{B} \quad (1.23)$$

Now use a vector calculus identity on the LHS and (M4) on the RHS to obtain

$$\nabla \nabla \cdot \mathbf{E} - \nabla^2 \mathbf{E} = -\mu_0 \frac{\partial \mathbf{J}}{\partial t} - \frac{1}{c^2} \frac{\partial^2 \mathbf{E}}{\partial t^2} \quad (1.24)$$

Finally use (M1) and rearrange to obtain

$$-\frac{1}{c^2} \frac{\partial^2 \mathbf{E}}{\partial t^2} + \nabla^2 \mathbf{E} = \frac{1}{\epsilon_0} \nabla \rho + \mu_0 \frac{\partial \mathbf{J}}{\partial t} \quad (1.25)$$

Similarly, if we take a curl of (M4) we obtain

$$\nabla \nabla \cdot \mathbf{B} - \nabla^2 \mathbf{B} = \mu_0 \nabla \times \mathbf{J} + \frac{1}{c^2} \frac{\partial}{\partial t} \nabla \times \mathbf{E} \quad (1.26)$$

and so using (M2) and (M3) gives

$$-\frac{1}{c^2} \frac{\partial^2 \mathbf{B}}{\partial t^2} + \nabla^2 \mathbf{B} = -\mu_0 \nabla \times \mathbf{J} \quad (1.27)$$

Equations (1.25) and (1.27) are inhomogeneous wave equations. In vacuum, i.e. when $\rho = \mathbf{J} = 0$, these equations imply that each component of \mathbf{E} and \mathbf{B} satisfies the homogeneous wave equation. The parameter c enters these wave equations in exactly the same way as the speed parameter of the waves. Thus we expect Maxwell's equation to admit solutions describing waves propagating with speed c , i.e., at the speed of light. This is not a coincidence: Maxwell's theory explains that light waves *are* electromagnetic waves. It also predicts the existence of other kinds of electromagnetic waves: radio, microwaves, infrared, ultraviolet, X-rays, gamma rays and predicts that electromagnetic waves are produced when charges and currents vary in time. Electromagnetic waves exist even in vacuum, i.e., when ρ and \mathbf{J} vanish. We will see later that they carry energy. This emphasizes that \mathbf{E} and \mathbf{B} are true physical degrees of freedom, not just a convenient way of describing the force on a test body. We will study electromagnetic waves in more detail later.

1.5 *Averaging*

We need to return to an issue we glossed over when we defined ρ and \mathbf{J} . Normal matter is made of atoms, with typical radius 10^{-10} m. An atom consists of a positively charged



Figure 2. The macroscopic Maxwell equations on a plaque on the floor in front of the statue (Fig. 1) of Maxwell in Edinburgh.

atomic nucleus surrounded by negatively charged electrons which fill out quantum mechanical orbitals. A typical radius for an atomic nucleus is 10^{-15}m , i.e., much smaller than the size of an atom. This means that the charge density of matter consists of enormous positive spikes at the location of atomic nuclei and then more diffuse negative clouds at the locations of the electron orbitals. And (in a solid) this repeats every 10^{-10}m or so. This is not a very smooth function!

In most practical applications, one is only interested in physics at *macroscopic* length scales much greater than the *microscopic* scale defined by the size of atoms. At macroscopic scales one cannot resolve the spiky microscopic structure of the charge distribution. Instead we can define a macroscopic charge distribution by *averaging* the charge distribution over microscopic scales.¹¹ The details of how we do this are not important - one way is to define

$$\rho_{\text{macro}}(t, \mathbf{x}) = \int f(\mathbf{x} - \mathbf{x}') \rho_{\text{micro}}(t, \mathbf{x}') d^3 \mathbf{x}' \quad (1.28)$$

where $f(\mathbf{y})$ is some smooth positive “smearing” function satisfying $f(\mathbf{y}) = 0$ for $|\mathbf{y}| > L$ and $\int f dV = 1$, where L is a length large compared to microscopic length scales. The averaging procedure converts the function ρ_{micro} which varies rapidly on microscopic scales into a function ρ_{macro} which varies only on macroscopic scales. Similar averaging is applied to the current density and to the electric and magnetic fields.

The version of Maxwell’s equations that we wrote above is the *microscopic* version of Maxwell’s equations, i.e., the ρ and \mathbf{J} appearing in these equations are the spiky

¹¹Averaging is also needed in other branches of classical physics such as fluid mechanics.

microscopic versions of these functions. But one can apply the averaging procedure to Maxwell's equations themselves to obtain equations involving the smooth macroscopic charge/current distribution and macroscopic \mathbf{E} , \mathbf{B} fields. In vacuum (i.e. vanishing ρ , \mathbf{J}) it is clear that the macroscopic equations take exactly the same form as the microscopic equations (the averaging process is linear). However, a more careful treatment of the definition of ρ_{macro} reveals that the equations are modified inside matter. You will learn about this in Part II Electrodynamics. The conclusion is that one has to introduce two new fields \mathbf{D} and \mathbf{H} and make the substitutions $\mathbf{E} \rightarrow \mathbf{D}/\epsilon_0$ and $\mathbf{B} \rightarrow \mu_0\mathbf{H}$ in (M1) and (M4). The resulting equations (shown in Fig. 2) are called the *macroscopic* Maxwell equations. To obtain a closed system of equations one needs to specify how \mathbf{D} and \mathbf{H} are related to \mathbf{E} and \mathbf{B} . In simple materials one has $\mathbf{D} = \epsilon\mathbf{E}$ and $\mathbf{H} = \mathbf{B}/\mu$ for constants ϵ, μ depending on the material. If $\epsilon \approx \epsilon_0$ and $\mu \approx \mu_0$ (which is the case for air under normal conditions) then the macroscopic equations are identical to the microscopic equations.

In this course we will work exclusively with the Maxwell equations as written above. This means that we are considering either (i) the microscopic equations, or (ii) the macroscopic equations in vacuum, or (iii) the macroscopic equations inside a material with $\epsilon \approx \epsilon_0$ and $\mu \approx \mu_0$.

1.6 Conductors and Ohm's law

A *conductor* is a material containing charges which can move freely in response to electric and magnetic fields. A familiar example of a conductor is a metal. In a metal, some electrons are not bound to individual atoms but are instead able to move throughout the material in response to external fields. In this course, whenever we refer to a conductor we mean a solid metal. We will not discuss other types of conductor such as a liquid metal, or a plasma. A material without many free charges is a poor conductor, also called an *insulator*.

Consider a conductor at rest. If we apply an electromagnetic field then, for many materials, under a wide range of conditions, a current flows in the conductor in the direction of \mathbf{E} . The dependence of \mathbf{J} on \mathbf{E} is well-described by *Ohm's law*:

$$\mathbf{J} = \sigma\mathbf{E} \tag{1.29}$$

where σ is called the *conductivity* of the material.¹² The conductivity is very large for good conductors (e.g. metals) and very small for insulators (e.g. diamond).

In contrast with Maxwell's equations, Ohm's law is not a fundamental law of nature but simply an equation that is observed to hold for many materials. A proper

¹²Some materials have direction-dependent conductivity, for which Ohm's law takes the form $J_i = \sigma_{ij}E_j$ where σ_{ij} is the *conductivity tensor*.

description of *why* it holds for certain materials requires a quantum mechanical description of the material in question. However, there is a simple classical model, the *Drude model*, which gives some understanding of the physics. (This model will be discussed in more detail in Part II Electrodynamics.) When we apply an electromagnetic field to a conductor, the free charges will accelerate according to the Lorentz force law (1.13). However, they will be slowed down by collisions with other particles in the material (e.g. the ions of the crystal lattice in a solid metal). The combined effect, when averaged over time and over many particles, is to give the free charges a non-zero *drift velocity* \mathbf{v}_d . To calculate this, assume that after each collision the velocity of each free charge is essentially random so, when averaged over many particles, the velocity is zero after each collision. So if the average time between collisions is τ then the velocity reduces from $\dot{\mathbf{x}}$ to 0 in time τ so the acceleration is roughly $-\dot{\mathbf{x}}/\tau$, hence we can model the collisions by a drag force $-m\dot{\mathbf{x}}/\tau$. Thus the equation of motion of a free charge becomes

$$m\ddot{\mathbf{x}} = q(\mathbf{E} + \dot{\mathbf{x}} \times \mathbf{B}) - m\dot{\mathbf{x}}/\tau \quad (1.30)$$

For simplicity, assume that \mathbf{E} and \mathbf{B} are constant (or slowly varying). One can show that this equation implies that $\dot{\mathbf{x}}$ rapidly settles down to a constant value, which we identify with \mathbf{v}_d . Thus \mathbf{v}_d is determined, in terms of \mathbf{E} and \mathbf{B} , by the vanishing of the RHS of this equation. For small fields, \mathbf{v}_d will be linear in \mathbf{E} and \mathbf{B} . But this implies that the $\dot{\mathbf{x}} \times \mathbf{B}$ term is second order and can be neglected. This leaves the solution¹³

$$\mathbf{v}_d = \frac{q\tau}{m}\mathbf{E} \quad (1.31)$$

Thus \mathbf{v}_d lies in the direction of \mathbf{E} . If there are n free charges per unit volume then the resulting current is

$$\mathbf{J} = nq\mathbf{v}_d = \frac{nq^2\tau}{m}\mathbf{E} \quad (1.32)$$

which explains Ohm's law.

Consider a conductor occupying a region V . Substituting (1.29) into the charge conservation equation (1.10) gives

$$0 = \frac{\partial \rho}{\partial t} + \sigma \nabla \cdot \mathbf{E} = \frac{\partial \rho}{\partial t} + \frac{\sigma}{\epsilon_0} \rho \quad (1.33)$$

where we used (M1) in the second equality. The general solution of this equation is

$$\rho(t, \mathbf{x}) = \rho(0, \mathbf{x})e^{-t/t_{\text{decay}}} \quad \text{where} \quad t_{\text{decay}} = \frac{\epsilon_0}{\sigma} \quad (1.34)$$

¹³One can now determine the condition for the $\dot{\mathbf{x}} \times \mathbf{B}$ term to be negligible compared to \mathbf{E} , which is $|q\tau B/m| \ll 1$. This condition is satisfied unless the magnetic field is very large.

Hence, inside V , any non-zero charge density decays exponentially with timescale t_{decay} . For a good conductor such as a metal, t_{decay} is a very small, so the charge density decays very rapidly. Where does this charge go? The above argument holds in the interior of V , so all of the charge must end up on the *surface* of V . We will discuss such surface charges later.

Finally: our discussion of Ohm's law assumed that the conductor was at rest. Consider now a conductor moving with velocity \mathbf{v} , i.e., a metal in which the ions of the crystal lattice have velocity \mathbf{v} . Assuming the conductor is electrically neutral ($\rho = 0$), Ohm's law generalizes to

$$\mathbf{J} = \sigma (\mathbf{E} + \mathbf{v} \times \mathbf{B}) \quad (1.35)$$

This can be understood using the Drude model by considering the velocity of the free charges relative to the ions of the lattice.

2 Electrostatics

2.1 Time-independence

We will start our exploration of the physical consequences of Maxwell's equations by considering situations with no dependence on time. The Maxwell equations simplify to

$$\nabla \cdot \mathbf{E} = \frac{\rho}{\epsilon_0} \quad \nabla \times \mathbf{E} = 0 \quad (2.1)$$

$$\nabla \cdot \mathbf{B} = 0 \quad \nabla \times \mathbf{B} = \mu_0 \mathbf{J} \quad (2.2)$$

where \mathbf{E} , \mathbf{B} , ρ and \mathbf{J} depend only on \mathbf{x} . The terms that mix \mathbf{E} and \mathbf{B} in the equations of motion are absent. If $\rho(\mathbf{x})$ is a known function then equations (2.1) determine \mathbf{E} . These are the equations of *electrostatics*, the subject of this chapter. Similarly, if $\mathbf{J}(\mathbf{x})$ is a known function then equations (2.2) determine \mathbf{B} . These are the equations of *magnetostatics* the subject of the next chapter.

It is not always the case that ρ and \mathbf{J} are known functions of \mathbf{x} . In general, charged matter responds to the presence of \mathbf{E} and \mathbf{B} via the Lorentz force law. Thus, in general, ρ and \mathbf{J} would depend on \mathbf{E} and \mathbf{B} . A simple example of this is a conductor, where \mathbf{J} is given by Ohm's law. In this case, there is still coupling between equations (2.1) and (2.2).

Strictly speaking, in addition to time-independence, electrostatics refers to a situation in which (a) all charges are at rest, so the current density \mathbf{J} vanishes; and (b) the magnetic field \mathbf{B} also vanishes. So electrostatics is the study of solutions for which

$$\rho = \rho(\mathbf{x}) \quad \mathbf{J} = 0 \quad \mathbf{E} = \mathbf{E}(\mathbf{x}) \quad \mathbf{B} = 0 \quad (2.3)$$

However, much of the discussion in this chapter uses only (2.1) and is still valid even for $\mathbf{J} \neq 0$. Only when we discuss the behaviour of conductors in electrostatics will we need to use $\mathbf{J} = 0$.

2.2 Scalar potential

The second equation of (2.1) implies that (in a simply connected region of space) there exists a scalar field $\Phi(\mathbf{x})$ such that

$$\mathbf{E} = -\nabla\Phi \quad (2.4)$$

$\Phi(\mathbf{x})$ is called the *scalar potential*.

To reveal the physical interpretation of Φ , consider a test body of charge q moving in a time independent electric field. From Newton's second law and the Lorentz force law we have the equation of motion

$$m\ddot{\mathbf{x}} = \mathbf{F} = q\mathbf{E} = -q\nabla\Phi \quad (2.5)$$

Taking the scalar product with $\dot{\mathbf{x}}$ gives

$$0 = m\dot{\mathbf{x}} \cdot \ddot{\mathbf{x}} + q\dot{\mathbf{x}} \cdot \nabla\Phi = \frac{dE}{dt} \quad (2.6)$$

where

$$E = \frac{1}{2}m\dot{\mathbf{x}}^2 + q\Phi(\mathbf{x}) \quad (2.7)$$

So E is a conserved quantity. Since the first term is the kinetic energy of the test body we interpret E as the total energy of the test body. We therefore interpret the second term $q\Phi(\mathbf{x})$ as the *potential energy* of a test body of charge q and position \mathbf{x} in an electrostatic field.

The electric field (1.14) produced by a static point charge Q at position \mathbf{x}_1 arises from the scalar potential

$$\Phi(\mathbf{x}) = \frac{Q}{4\pi\epsilon_0|\mathbf{x} - \mathbf{x}_1|} \quad (2.8)$$

Similarly the scalar potential due to N point charges Q_i with positions \mathbf{x}_i is

$$\Phi(\mathbf{x}) = \sum_{i=1}^N \frac{Q_i}{4\pi\epsilon_0|\mathbf{x} - \mathbf{x}_i|} \quad (2.9)$$

Note that (2.4) defines Φ only up to a constant of integration. In the above expressions we have fixed this ambiguity by requiring that $\Phi \rightarrow 0$ as $|\mathbf{x}| \rightarrow \infty$. This

is conventional when dealing with a localized charge distribution. More generally, the *potential difference* between two points is unambiguous, and given by

$$\Phi(\mathbf{x}_2) - \Phi(\mathbf{x}_1) = \int_C \nabla\Phi \cdot d\mathbf{x} = - \int_C \mathbf{E} \cdot d\mathbf{x} \quad (2.10)$$

where C is any curve from \mathbf{x}_1 to \mathbf{x}_2 . Note that $W = q(\Phi(\mathbf{x}_2) - \Phi(\mathbf{x}_1))$ is the work needed to move a test body from \mathbf{x}_1 to \mathbf{x}_2 .

Example. Let's relate Ohm's law (1.29) to the more elementary form you may have seen previously. Consider a wire, of non-zero thickness, made of conducting material. Assume that a time-independent electric field \mathbf{E} causes a time-independent current \mathbf{J} to flow in the wire, as given by (1.29).¹⁴ Let \mathbf{x}_1 and \mathbf{x}_2 be two points of the wire, with $\Phi(\mathbf{x}_2) > \Phi(\mathbf{x}_1)$. The potential difference between the points is

$$V \equiv \Phi(\mathbf{x}_2) - \Phi(\mathbf{x}_1) = - \int_C \mathbf{E} \cdot d\mathbf{x} = \int_{-C} \mathbf{E} \cdot d\mathbf{x} = \int_{-C} \frac{\mathbf{J}}{\sigma} \cdot d\mathbf{x} \quad (2.11)$$

where $-C$ is the curve C traversed in the opposite direction (i.e. from \mathbf{x}_2 to \mathbf{x}_1). Now assume that (i) the section of wire between the two points has length ℓ and constant cross-sectional area A ; (ii) the conductivity σ is constant; (iii) \mathbf{J} is approximately constant across the wire and in the direction of the wire. We then have $V \approx |\mathbf{J}|\ell/\sigma$ and the current in the wire is

$$I = \int_S \mathbf{J} \cdot d\mathbf{S} \approx |\mathbf{J}|A \quad (2.12)$$

where S denotes a cross-section of the wire. Eliminating $|\mathbf{J}|$ gives

$$V = IR \quad \text{where} \quad R = \frac{\ell}{\sigma A} \quad (2.13)$$

R is the *resistance* of the section of wire between the two points. More generally, even if we do not assume (i), (ii) and (iii), it is clear that V and I are both linearly related to \mathbf{J} and so we would expect a relation of the form $V = IR$ for some constant R .

We return to the general discussion. Substituting (2.4) into (M1) gives a Poisson equation for Φ :

$$\nabla^2\Phi = -\frac{\rho}{\epsilon_0} \quad (2.14)$$

Let's assume that we are solving this equation on \mathbb{R}^3 (rather than on some subregion) and that ρ vanishes at infinity. You learned in Methods that the solution can be written using the Green function for Poisson's equation:

$$\Phi(\mathbf{x}) = \int \frac{\rho(\mathbf{x}')}{4\pi\epsilon_0|\mathbf{x} - \mathbf{x}'|} d^3\mathbf{x}' \quad (2.15)$$

¹⁴This is not an electrostatic situation because we're considering $\mathbf{J} \neq 0$.

Again we have imposed the condition that Φ vanishes at infinity. In this expression, the integral is over \mathbb{R}^3 . From this we obtain the electric field for a general charge distribution

$$\mathbf{E}(\mathbf{x}) = -\nabla\Phi = -\int \frac{\rho(\mathbf{x}')}{4\pi\epsilon_0} \nabla \frac{1}{|\mathbf{x} - \mathbf{x}'|} d^3\mathbf{x}' = \int \frac{\rho(\mathbf{x}')(\mathbf{x} - \mathbf{x}')}{4\pi\epsilon_0|\mathbf{x} - \mathbf{x}'|^3} d^3\mathbf{x}' \quad (2.16)$$

In symmetrical situations, it is often easier to determine Φ and \mathbf{E} using Gauss' law (below) instead of trying to evaluate these integrals.

Example. Let's calculate the external forces required to hold two static charged bodies at rest (without external forces the bodies would attract or repel each other). Let the bodies occupy regions V_1 and V_2 and have charge densities ρ_1 and ρ_2 . Let \mathbf{E}_i be the electric field produced by ρ_i , as given by (2.16). By linearity of Maxwell's equations the total electric field is $\mathbf{E} = \mathbf{E}_1 + \mathbf{E}_2$. The electrostatic force exerted by the second body on the first is given by the Lorentz force law (1.16) as

$$\mathbf{F}_{12} = \int_{V_1} d^3\mathbf{x}_1 \rho_1(\mathbf{x}_1) \mathbf{E}_2(\mathbf{x}_1) = \int_{V_1} \int_{V_2} d^3\mathbf{x}_1 d^3\mathbf{x}_2 \frac{\rho_1(\mathbf{x}_1)\rho_2(\mathbf{x}_2)(\mathbf{x}_1 - \mathbf{x}_2)}{4\pi\epsilon_0|\mathbf{x}_1 - \mathbf{x}_2|^3} \quad (2.17)$$

where we used (2.16) in the second equality, and restricted the region of integration to V_2 because that is where ρ_2 is non-zero. The external force on the first body that is required to maintain equilibrium is $-\mathbf{F}_{12}$.

Note that the RHS of (2.17) is antisymmetric in the labels 1 and 2 so we deduce that the force exerted by the first body on the second body is $\mathbf{F}_{21} = -\mathbf{F}_{12}$ hence the force obeys Newton's third law. An almost identical calculation gives the force exerted by a static charged body on *itself*: the result is given by setting $\rho_1 = \rho_2 = \rho$ and $V_1 = V_2 = V$ in the above integral. The integrand is then antisymmetric in \mathbf{x}_1 and \mathbf{x}_2 so this self-force vanishes.

Similarly, one can use (1.17) to calculate the torque that each body exerts on the other, and to show that the torque that each body exerts on itself vanishes.

The correspondence with gravitation

A test body of mass m moving in a Newtonian gravitational field \mathbf{g} experiences a force

$$\mathbf{F} = m\mathbf{g} \quad (2.18)$$

The Newtonian gravitational field can be expressed in terms of a potential Φ_g :

$$\mathbf{g} = -\nabla\Phi_g \quad (2.19)$$

This satisfies a Poisson equation

$$\nabla^2\Phi_g = 4\pi G\rho_g \quad (2.20)$$

where G is Newton's gravitational constant and ρ_g is the mass density of matter. We therefore have a 1-1 correspondence between electrostatic and gravitational quantities:

Electrostatics	q	\mathbf{E}	Φ	ρ	$-1/\epsilon_0$
Gravitation	m	\mathbf{g}	Φ_g	ρ_g	$4\pi G$

With this correspondence you can use the results of this chapter to solve problems in gravitation. The two differences between electrostatics and Newtonian gravitation are (i) q and ρ can be positive or negative but m and ρ_g are always positive; (ii) the relative minus sign in the final column of the above table: this implies that like charges repel in electrostatics but the gravitational force between (positive) masses is always attractive.

2.3 Electrostatic energy

The electrostatic energy of a charge distribution is defined as the work required to create the charge distribution by bringing the charge in from infinity.

Consider a system of N static particles with charges q_i and positions \mathbf{x}_i . The electrostatic energy is

$$E = \frac{1}{2} \sum_{i \neq j} \frac{q_i q_j}{4\pi\epsilon_0 |\mathbf{x}_i - \mathbf{x}_j|} \quad (2.21)$$

To see this, consider adding the particles one at a time, treating each as a test body. When we introduce the first particle there is no external field and so no energy. But after we've added this particle, the field is now

$$\Phi_1(\mathbf{x}) = \frac{q_1}{4\pi\epsilon_0 |\mathbf{x} - \mathbf{x}_1|} \quad (2.22)$$

We now add the second particle by bringing it in from infinity. The energy of the configuration is now equal to the work done to add this particle, which is

$$q_2(\Phi_1(\mathbf{x}_2) - \Phi_1(\infty)) = q_2 \Phi_1(\mathbf{x}_2) = \frac{q_1 q_2}{4\pi\epsilon_0 |\mathbf{x}_1 - \mathbf{x}_2|} \quad (2.23)$$

The field is now

$$\Phi_2(\mathbf{x}) = \frac{q_1}{4\pi\epsilon_0 |\mathbf{x} - \mathbf{x}_1|} + \frac{q_2}{4\pi\epsilon_0 |\mathbf{x} - \mathbf{x}_2|} \quad (2.24)$$

We now repeat with the third particle and so on, obtaining (2.21) by induction (the factor of 1/2 prevents double counting).

Now we want to calculate the electrostatic energy of a continuous distribution of charge. We start by proving an intermediate result. Consider a situation in which we have various static charges bodies. Let $\rho_1(\mathbf{x})$ be the charge density of one of the bodies. By the superposition principle, we can separate Φ into the field Φ_1 produced

by the body (given by setting $\rho = \rho_1$ in (2.15)) and an "external" field Φ_{ext} produced by all the other bodies. Treat the first body as a superposition of a large number N of particles with charges q_i and positions \mathbf{x}_i , i.e.,

$$\rho_1(\mathbf{x}) = \sum_{i=1}^N q_i \delta^{(3)}(\mathbf{x} - \mathbf{x}_i) \quad (2.25)$$

Then the work done against the *external* field to create the first body is

$$W_{\text{ext}} = \sum_{i=1}^N q_i \Phi(\mathbf{x}_i) = \sum_{i=1}^N \int d^3\mathbf{x} q_i \delta^{(3)}(\mathbf{x} - \mathbf{x}_i) \Phi_{\text{ext}}(\mathbf{x}) = \int d^3\mathbf{x} \rho_1(\mathbf{x}) \Phi_{\text{ext}}(\mathbf{x}) \quad (2.26)$$

Armed with this result, we now consider a continuous distribution of charge $\rho(\mathbf{x})$ which produces potential $\Phi(\mathbf{x})$ given by (2.15). To calculate the electrostatic energy define $\rho_\lambda(\mathbf{x}) = \lambda\rho(\mathbf{x})$ where $0 \leq \lambda \leq 1$. The charge distribution ρ_λ produces potential $\Phi_\lambda(\mathbf{x}) = \lambda\Phi(\mathbf{x})$. Let $E(\lambda)$ be the electrostatic energy of ρ_λ . Now increase $\lambda \rightarrow \lambda + \delta\lambda$ by bringing in charge density $\delta\rho_\lambda(\mathbf{x}) = \rho(\mathbf{x})\delta\lambda$ from infinity. View $\delta\rho_\lambda$ as a body immersed in the external field Φ_λ . Using the above result, the work required to produced $\delta\rho_\lambda$ by bringing charge from infinity is

$$\begin{aligned} \delta E &= \int d^3\mathbf{x} \delta\rho_\lambda(\mathbf{x}) \Phi_\lambda(\mathbf{x}) = \int d^3\mathbf{x} d^3\mathbf{x}' \frac{\delta\rho_\lambda(\mathbf{x}) \rho_\lambda(\mathbf{x}')}{4\pi\epsilon_0 |\mathbf{x} - \mathbf{x}'|} \\ &= \lambda\delta\lambda \int d^3\mathbf{x} d^3\mathbf{x}' \frac{\rho(\mathbf{x}) \rho(\mathbf{x}')}{4\pi\epsilon_0 |\mathbf{x} - \mathbf{x}'|} \equiv \lambda\delta\lambda I \end{aligned} \quad (2.27)$$

where we used (2.15) in the second equality. We now divide through by $\delta\lambda$ and take $\delta\lambda \rightarrow 0$ to obtain $dE/d\lambda = \lambda I$. Integrating w.r.t. λ gives $E = (1/2)\lambda^2 I + E_0$ where E_0 is a constant which we set to zero because $E(\lambda)$ should vanish when $\lambda = 0$ (when no charge is present). Finally setting $\lambda = 1$ gives us the electrostatic energy of the charge distribution $\rho(\mathbf{x})$:

$$E = \frac{1}{2} \int d^3\mathbf{x} d^3\mathbf{x}' \frac{\rho(\mathbf{x}) \rho(\mathbf{x}')}{4\pi\epsilon_0 |\mathbf{x} - \mathbf{x}'|} = \frac{1}{2} \int d^3\mathbf{x} \rho(\mathbf{x}) \Phi(\mathbf{x}) \quad (2.28)$$

where we used (2.15) again in the second equality.

We can use Poisson's equation (2.14) to eliminate ρ from the RHS above:

$$\begin{aligned} E &= -\frac{\epsilon_0}{2} \int d^3\mathbf{x} \Phi(\mathbf{x}) \nabla^2 \Phi(\mathbf{x}) = -\frac{\epsilon_0}{2} \int d^3\mathbf{x} [\nabla \cdot (\Phi \nabla \Phi) - \nabla \Phi \cdot \nabla \Phi] \\ &= \frac{\epsilon_0}{2} \int d^3\mathbf{x} (\nabla \Phi)^2 = \frac{\epsilon_0}{2} \int d^3\mathbf{x} \mathbf{E}(\mathbf{x})^2 \end{aligned} \quad (2.29)$$

In the third equality we used the divergence theorem and the fact that $\Phi\nabla\Phi$ vanishes rapidly¹⁵ at infinity to neglect a surface term. This formula shows that instead of thinking of electrostatic energy as potential energy associated with the charge distribution we can view it as energy carried by the electric field, with energy density

$$w = \frac{\epsilon_0}{2} \mathbf{E}^2. \quad (2.30)$$

When we consider time-dependent electromagnetic fields, we will see that it is essential that we adopt the latter point of view and regard the energy as living in the electric and magnetic fields.

We have derived two formulae for electrostatic energy: one for a system of point particles and one for a continuous charge distribution. Unfortunately they are inconsistent with each other! To see this, consider the electric field for a pair of particles:

$$\mathbf{E}(\mathbf{x}) = \sum_{i=1}^2 \frac{q_i(\mathbf{x} - \mathbf{x}_i)}{4\pi\epsilon_0|\mathbf{x} - \mathbf{x}_i|^3} \quad (2.31)$$

so the energy density is

$$w = w_{\text{self}} + w_{\text{int}} \quad (2.32)$$

where “int” stands for “interaction” and

$$w_{\text{self}} = \sum_{i=1}^2 \frac{q_i^2}{32\pi^2\epsilon_0|\mathbf{x} - \mathbf{x}_i|^4} \quad w_{\text{int}} = \frac{q_1q_2(\mathbf{x} - \mathbf{x}_1) \cdot (\mathbf{x} - \mathbf{x}_2)}{16\pi^2\epsilon_0|\mathbf{x} - \mathbf{x}_1|^3|\mathbf{x} - \mathbf{x}_2|^3} \quad (2.33)$$

It can be shown that the integral of w_{int} reproduces the result from (2.21). However the integral of w_{self} is *infinite!*¹⁶ The term w_{self} describes the “self-energy” arising from the interaction of each particle with its own electrostatic field. Since the field diverges at the location of the particle, the self-energy is infinite. The disagreement between (2.29) and (2.21) arises because we did not include this infinite self-energy in (2.21).

This kind divergence is typical when one attempts to introduce point-like particles into a classical field theory. For continuous charge distributions, (2.29) is finite. So we will work with (2.29) when we are discussing continuous charge distributions but return to (2.21) when we discuss point particles. Notice that this simply corresponds to shifting the energy by a constant (i.e. a term independent of \mathbf{x}_i), albeit an infinite one.

¹⁵ $\Phi \propto 1/|\mathbf{x}|$ as $|\mathbf{x}| \rightarrow \infty$ so $\Phi\nabla\Phi$ is $\mathcal{O}(1/|\mathbf{x}|^3)$ so the integral over a large sphere is $\mathcal{O}(1/|\mathbf{x}|)$.

¹⁶This can be seen by converting to spherical polar coordinates centered on \mathbf{x}_i ($i = 1, 2$): the i th term in the integrand diverges as r^{-4} at small r . The volume element contributes a factor of r^2 but this is not enough to render the integral finite.

2.4 Gauss' law

Let V be a region of space with boundary S . Integrate (M1) over V and use the divergence theorem to obtain *Gauss' law*

$$\int_S \mathbf{E} \cdot d\mathbf{S} = \frac{Q[V]}{\epsilon_0} \quad (2.34)$$

where $Q[V]$ is the total charge inside V , as defined by (1.6). The LHS of Gauss' law is called the *electric flux across S* . So if one knows the electric flux across S then one can determine the total charge enclosed by S .

Gauss' law is simply an integral version of (M1), i.e., (M1) is equivalent to demanding that Gauss' law holds for any closed surface S . Sometimes (M1) or (2.14) is also called Gauss' law. Note that Gauss' law applies in general, not just in electrostatics. In a time-dependent situation, Q will depend on time because charge can enter or leave V .

Returning to electrostatics, we can use (2.4) to rewrite Gauss' law as

$$\int_S \nabla\Phi \cdot d\mathbf{S} = -\frac{Q[V]}{\epsilon_0} \quad (2.35)$$

Thus Gauss' law constrains the normal derivative of Φ on S .

In some symmetrical situations this form of Gauss' law can be used as a quick way of finding the electric field produced by a charge distribution. Let's look at some examples.

Example 1. Consider a sphere of radius R with a spherically symmetric charge density, i.e., $\rho = \rho(r)$ in spherical polar coordinates with $\rho = 0$ for $r > R$. By symmetry, the solution given by (2.15) must be a function of r only: $\Phi = \Phi(r)$. This implies $\mathbf{E} = E_r(r)\mathbf{e}_r$ where \mathbf{e}_r is a unit radial vector. Apply Gauss' law (2.34) taking S to be a surface of radius r . The result is

$$4\pi r^2 E_r(r) = \frac{Q(r)}{\epsilon_0} \quad (2.36)$$

where $Q(r)$ is the charge enclosed by S :

$$Q(r) = \int_0^r \int_0^\pi \int_0^{2\pi} \rho(r') r'^2 \sin\theta d\phi d\theta dr' = 4\pi \int_0^r \rho(r') r'^2 dr' \quad (2.37)$$

Hence the electric field is

$$E_r = \frac{Q(r)}{4\pi\epsilon_0 r^2} \quad (2.38)$$

For $r > R$ we have $Q(r) = Q$ where $Q \equiv Q(R)$ is the total charge of the sphere:

$$Q = 4\pi \int_0^R \rho(r)r^2 dr \quad (2.39)$$

Hence the electric field *outside* the sphere is the same as that of a charge Q at the origin. Inside the sphere, the field depends on $\rho(r)$. For example, if the charge density is constant then we have $Q(r) = (4/3)\pi r^3 \rho$ and $Q = (4/3)\pi R^3 \rho$ hence $Q(r) = (r/R)^3 Q$. So in the constant density case

$$E_r = \begin{cases} \frac{Q}{4\pi\epsilon_0 r^2} & \text{if } r > R \\ \frac{Qr}{4\pi\epsilon_0 R^3} & \text{if } r < R \end{cases} \quad (2.40)$$

The scalar potential can be determined from $E_r = -\Phi'(r)$. The result is

$$\Phi = \begin{cases} \frac{Q}{4\pi\epsilon_0 r} & \text{if } r > R \\ \frac{3Q}{8\pi\epsilon_0 R} - \frac{Qr^2}{8\pi\epsilon_0 R^3} & \text{if } r < R \end{cases} \quad (2.41)$$

where we fixed the constant of integration using $\Phi \rightarrow 0$ at infinity.

We can calculate the electrostatic energy of the sphere (with constant charge density) using either (2.28) or (2.29). The result is

$$E = \frac{3Q^2}{20\pi\epsilon_0 R}. \quad (2.42)$$

Example 2. An infinite charged cylinder with radius R . Now we use cylindrical polars (r, ϕ, z) where the cylinder is located at $r = R$ and assume the charge distribution is cylindrically symmetric, i.e., $\rho = \rho(r)$ with $\rho = 0$ for $r > R$. We assume that the symmetry implies $\Phi = \Phi(r)$. Let's apply Gauss' law to a cylinder of constant r . The total charge inside an infinite cylinder is infinite so we consider a finite cylinder with $a \leq z \leq a + h$. Applying Gauss' law to such a cylinder gives

$$2\pi r h E_r = \frac{Q(r, h)}{\epsilon_0} \quad (2.43)$$

on the LHS we have used the fact that \mathbf{E} points in the radial direction so in (2.34) we have $\mathbf{E} \cdot d\mathbf{S} = 0$ on the end caps ($z = a, a + h$) of the cylinder. So only the curved surface of the cylinder contributes to the integral. On the RHS the charge inside the finite cylinder of radius r and height h is

$$Q(r, h) = \int_0^r \int_a^{a+h} \int_0^{2\pi} \rho(r') r' d\phi dz dr' = h\lambda(r) \quad (2.44)$$

where

$$\lambda(r) = 2\pi \int_0^r \rho(r')r' dr' \quad (2.45)$$

Hence we have

$$E_r = \frac{\lambda(r)}{2\pi\epsilon_0 r} \quad (2.46)$$

For $r > R$ we have $\lambda(r) = \lambda$ where $\lambda \equiv \lambda(R)$ is the total charge per unit length of the cylinder. Inside the cylinder, if we assume constant charge density then we have $\lambda(r) = \pi r^2 \rho$ and $\lambda = \pi R^2 \rho$ so $\lambda(r) = (r/R)^2 \lambda$. So in the constant density case

$$E_r = \begin{cases} \frac{\lambda}{2\pi\epsilon_0 r} & \text{if } r > R \\ \frac{\lambda r}{2\pi\epsilon_0 R^2} & \text{if } r < R \end{cases} \quad (2.47)$$

The scalar potential is obtained from $E_r = -\Phi'(r)$. For $r > R$ this gives

$$\Phi = -\frac{\lambda}{2\pi\epsilon_0} \log\left(\frac{r}{R}\right) + \Phi_0 \quad (2.48)$$

where Φ_0 is an arbitrary constant. We've written the argument of the logarithm as r/R to make it dimensionless. In this case we cannot impose $\Phi \rightarrow 0$ at infinity so there is no natural way of fixing Φ_0 . The scalar potential in $r < R$ is determined using continuity at $r = R$ and so also depends on Φ_0 .

In this example, evaluating the electrostatic energy using (2.28) gives a result that depends on the unphysical parameter Φ_0 . On the other hand, if we use (2.29) then the integral over the region $r > R$ diverges. This emphasizes the point that the derivation of (2.28) and the passage from (2.28) to (2.29) both assumed that the charge distribution decays at infinity, which is not the case here. We'll see later that the formula for the energy density (2.30) is correct even without decay at infinity. So in this example the electrostatic energy density is finite but the electrostatic energy (per unit length) is infinite.

If we take the limit $R \rightarrow 0$ whilst keeping the charge per unit length λ fixed then we obtain an infinite *line charge* along the z -axis. The resulting \mathbf{E} field is given by $E_r = \lambda/(2\pi\epsilon_0 r)$. The charge density of this line charge can be written as

$$\rho(\mathbf{x}) = \lambda\delta(x)\delta(y) \quad (2.49)$$

More generally, a line charge is defined as a charge distribution for which $\rho(\mathbf{x})$ vanishes everywhere except on some curve (in this case a straight line). If s denotes arc length along the line then the *line charge density* $\lambda(s)$ is defined so that the total charge on an infinitesimal section of the line is $\lambda(s)ds$. In the above example $s = z$ and $\lambda(s)$ is constant.

2.5 Conductors and surface charges

Consider a conductor occupying a finite region of space V . Recall Ohm's law (1.29)

$$\mathbf{J} = \sigma \mathbf{E} \quad (2.50)$$

In electrostatics we have $\mathbf{J} = 0$ hence we must have $\mathbf{E} = 0$ inside a conductor in electrostatics. From Gauss' law (M1), it follows that ρ must vanish throughout V (indeed we saw in section 1.6 that the charge density decays exponentially with time inside a conductor and so it must vanish in a time-independent situation). Physically, what happens if we apply an external electric field (e.g. by bringing some charge near to V) is that the free charges inside V will move in response to this electric field. They will continue moving until they have rearranged themselves in such a way that they produce an electric field which cancels out the external field. Note that vanishing \mathbf{E} implies that Φ is constant in V . Thus, in electrostatics, in the interior of a conductor we have

$$\mathbf{E}(\mathbf{x}) = 0 \quad \Phi(\mathbf{x}) = \text{constant} \quad \rho(\mathbf{x}) = 0 \quad \mathbf{x} \in V \quad (2.51)$$

If we bring a positive charge Q close to V then (in a metal) the free electrons in V will be attracted towards this positive charge. So we would expect there to be an excess of electrons on the part of S (the boundary of V) nearest Q and a deficit of electrons on the part of S furthest from Q . Similarly, if a conductor is prepared in an initial state with some non-zero charge density then this charge will decay according to (1.34) and eventually all of the charge will reside on S . In both cases, even though the charge density vanishes in V , there will be a non-vanishing *surface charge density* on S .¹⁷ A surface charge density is described by a function $\sigma(\mathbf{x})$ where $\mathbf{x} \in S$ such that the total charge on an element dS of S is $\sigma(\mathbf{x})dS$. The total surface charge is

$$Q_{\text{surface}} = \int_S \sigma(\mathbf{x})dS \quad (2.52)$$

If the conductor is electrically neutral (contains equal amounts of positive and negative charge) then Q_{surface} will vanish even if σ is non-zero.

A surface charge corresponds to a contribution to the charge density ρ that is proportional to a delta-function supported on S . For example, a surface charge density $\sigma(x, y)$ in the plane $z = z_0$ is described by the charge density $\rho(x, y, z) = \sigma(x, y)\delta(z - z_0)$.

Let's consider the behaviour of the electric field at a surface S carrying a non-zero surface charge. We will do this in complete generality, assuming neither electrostatics

¹⁷The notion of surface charge is an idealization. In a physical conductor there is a non-zero charge density ρ confined to a region of thickness a centred on S , where a is typically the size of a few atoms.

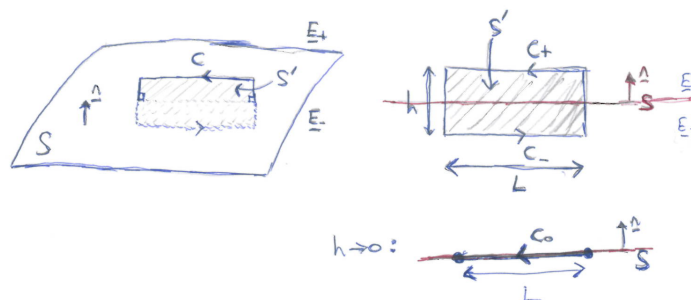

Figure 3. Rectangular surface S' with boundary C used in the argument for continuity of the tangential components of \mathbf{E} .

nor that S is the boundary of a conductor. Since ρ is proportional to a delta-function on S , Gauss' law (M1) implies that $\nabla \cdot \mathbf{E}$ is proportional to a delta function on S , which implies that \mathbf{E} must be *discontinuous* across S . We can determine this discontinuity as follows.

Let \mathbf{E}_{\pm} be the electric field as one approaches S from above or below. Applying Stokes' theorem to (M3) gives

$$\int_C \mathbf{E} \cdot d\mathbf{x} = - \int_{S'} \frac{\partial \mathbf{B}}{\partial t} \cdot d\mathbf{S} \quad (2.53)$$

where S' is a surface whose boundary is the closed curve C . Take S' to be a rectangle with two sides of length L and two sides of length h where $L \gg h$. Choose S' to be small compared to the scale on which S is curved, so we can treat S as approximately planar. Orient S' perpendicular to S so that the two long sides are parallel to S and lie just above and just below S . See Fig. 3. Denote the two long sides as C_{\pm} . Now take the limit $h \rightarrow 0$. In this limit, S' and C_{\pm} collapses to a line C_0 in S . In (2.53), if we assume that $\partial \mathbf{B} / \partial t$ is bounded then the RHS tends to zero (because the region of integration collapses to a line). We are left with

$$\int_{C_0} (\mathbf{E}_+ - \mathbf{E}_-) \cdot d\mathbf{x} = 0 \quad (2.54)$$

The minus sign arises because the direction of C_- is opposite to C_0 . By taking L small enough we can ensure that the integrand does not vary significantly along C_0 and hence

$$(\mathbf{E}_+ - \mathbf{E}_-) \cdot \mathbf{t} = 0 \quad (2.55)$$

where \mathbf{t} is the tangent to C_0 . But we can orient C_0 in any direction tangential to S so we deduce that the (2.55) must hold for *any* vector \mathbf{t} that is tangential to S . Hence the components of \mathbf{E} tangential to S are continuous across S .

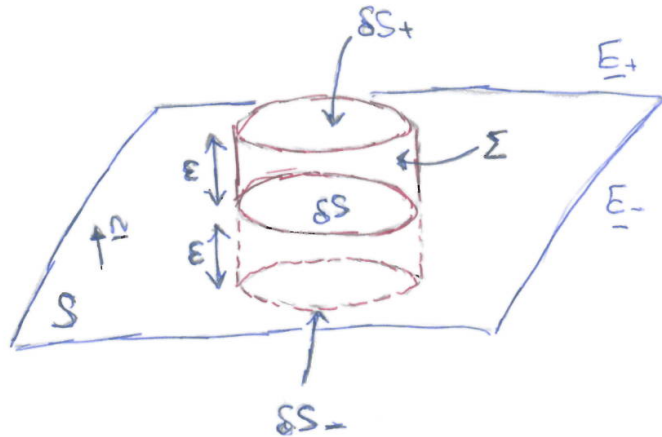

Figure 4. “Pill-box” volume δV with boundary $\delta S_+ \cup \delta S_- \cup \Sigma$ used to calculate the discontinuity in the normal component of \mathbf{E} .

To determine the behaviour of the component of \mathbf{E} normal to S , consider a “pill-box” region δV obtained by translating a section δS of S a small distance ϵ slightly outside (δS_+) and slightly inside (δS_-) the surface S . See Fig. 4. The boundary of δV is $\delta S_+ \cup \delta S_- \cup \Sigma$. Gauss’ law (2.34) gives

$$\int_{\delta S_+ \cup \delta S_- \cup \Sigma} \mathbf{E} \cdot d\mathbf{S} = \frac{1}{\epsilon_0} \int_{\delta S} \sigma dS \quad (2.56)$$

where the RHS is the total charge inside δV : we neglect any contribution from charge density not supported on S because this will be negligible for small enough ϵ . For small ϵ , the integral over Σ on the LHS is negligible. We are left with

$$\int_{\delta S} (\mathbf{E}_+ - \mathbf{E}_-) \cdot d\mathbf{S} = \frac{1}{\epsilon_0} \int_{\delta S} \sigma dS \quad (2.57)$$

where we have taken the limit $\epsilon \rightarrow 0$ in which δS_{\pm} reduces to δS . Since $d\mathbf{S} = \mathbf{n}dS$ and δS is arbitrary we have

$$(\mathbf{E}_+ - \mathbf{E}_-) \cdot \mathbf{n} = \frac{\sigma}{\epsilon_0} \quad (2.58)$$

So the normal component of \mathbf{E} is discontinuous across S . Combining with (2.55), we finally obtain

$$\mathbf{E}_+ - \mathbf{E}_- = \frac{\sigma}{\epsilon_0} \mathbf{n} \quad (2.59)$$

i.e. in the presence of a surface charge σ on S , there is a discontinuity in the electric field at S that is normal to S with magnitude σ/ϵ_0 . Note that in this formula, \mathbf{n} points to the + region.

We now specialize to the surface of a conductor in electrostatics. In this case, we have $\mathbf{E}_- = 0$ and so

$$\mathbf{E}_+ = \frac{\sigma}{\epsilon_0} \mathbf{n} \quad (2.60)$$

where \mathbf{n} points out of the conductor.

Although \mathbf{E} is discontinuous across S , in electrostatics the definition $\mathbf{E} = -\nabla\Phi$ implies that Φ must be continuous across S (because otherwise \mathbf{E} would exhibit δ -function behaviour at S instead of a discontinuity). Hence, even when approached from outside the conductor, S must be a surface of constant Φ (because Φ is constant inside V).¹⁸ Such a surface is called an *equipotential surface*.

A common problem in electrostatics is to determine Φ (or \mathbf{E}) outside a set of conductors, where the potential of each conductor is held fixed. If there are several conductors then they can have different potentials. In practice, this is achieved by connecting each conductor with thin conducting wires to a battery. The wires themselves are assumed to have a negligible effect on the electric field. If a conductor is held fixed at zero potential then it is said to be *earthed* (i.e. connected to the Earth, which is assumed to have zero potential). Charge can flow along the wires from the battery/Earth to the conductors, so in this type of problem the charge on each conductor is not fixed, but has to be determined. This is done by solving Poisson's equation in the region *outside* the conductors with *Dirichlet* boundary conditions, namely that Φ takes the prescribed value at the surface of each conductor (and vanishes at infinity). From the solution Φ one can then calculate \mathbf{E} at the surface of each conductor and determine the surface charge from (2.60). This then determines the total charge on each conductor.

Example 1. A conducting sphere of radius R is held at potential V and there is no charge outside the sphere. Let's determine the charge on the sphere.¹⁹ Outside the sphere, Φ satisfies Laplace's equation. The general spherically symmetric solution of Laplace's equation is $\Phi = A/r + B$ where A and B are constants. The boundary condition $\Phi = 0$ at infinity gives $B = 0$. The boundary condition $\Phi = V$ at $r = R$ fixed $A = VR$. So the solution is $\Phi = VR/r$ for $r > R$ (and $\Phi = V$ for $r < R$). The electric field is $\mathbf{E} = -\nabla\Phi = (VR/r^2)\mathbf{e}_r$ for $r > R$. At the surface of the sphere $\mathbf{E}_+ = (V/R)\mathbf{n}$ hence (2.60) gives $\sigma = \epsilon_0 V/R$. Therefore the total charge on the sphere is $Q = 4\pi R^2\sigma = 4\pi\epsilon_0 RV$. Sometimes one defines the *self-capacitance* C of an isolated conductor as the ratio Q/V so for a sphere we have $C = 4\pi\epsilon_0 R$.

¹⁸This also follows from $\mathbf{E} = -\nabla\Phi$, which implies that \mathbf{E} is orthogonal to surfaces of constant Φ . But (2.60) shows that \mathbf{E}_+ is orthogonal to S . Hence S must be a surface of constant Φ .

¹⁹In this case we can solve the problem immediately using (2.41). But we'll work through the method as if we did not know (2.41).

Example 2. A *capacitor* is a device for storing energy in the electric field. It consists of two spatially separated conductors. The conductors can be connected by wires to the terminals of a battery so that charge Q flows to one conductor and charge $-Q$ to the other one. The battery is then removed. Let V be the potential difference between the conductors, i.e., $V = \Phi_+ - \Phi_-$ where Φ_+ (Φ_-) is the potential of the positively (negatively) charged conductor. Since Poisson's equation is linear, V and Q will be linearly related so we can write

$$Q = CV \quad (2.61)$$

where C is a constant called the *capacitance*. It depends only on the shapes of the conductors, and their separation. If we add charge δQ to the positive conductor and $-\delta Q$ to the negative conductor then, to bring the charge in from infinity, we must do work $\delta Q\Phi_+ - \delta Q\Phi_- = V\delta Q$. Thus the energy of the system increases by $\delta E = \delta QV = Q\delta Q/C$. So $dE/dQ = Q/C$. Since $E = 0$ for $Q = 0$ we deduce that the energy stored by the capacitor is

$$E_{\text{capacitor}} = \frac{Q^2}{2C} = \frac{CV^2}{2} \quad (2.62)$$

This is the same thing as the energy in the electric field, as given by (2.29).

Consider a capacitor consisting of a pair of flat conducting plates, each of area A and separated by a distance d which is small compared to the size of the plates. To calculate C we assume the plates are separated in the z -direction and, since the separation is small compared to the size of the plates, we neglect any variation in the x and y directions. Of course this approximation will break down near the edges of the plates. In the region between the plates, the potential Φ satisfies Laplace's equation (as there is no charge there) and the general solution of the form $\Phi = \Phi(z)$ is $\Phi = A + Bz$. The potential difference is therefore $V = Bd$. Hence $\Phi = A + Vz/d$. This gives constant electric field $\mathbf{E} = -(V/d)\mathbf{k}$. From (2.60), the surface charge is $\sigma_+ = \epsilon_0 V/d$ on the upper plate ($\mathbf{n} = -\mathbf{k}$) and $\sigma_- = -\epsilon_0 V/d$ on the lower plate ($\mathbf{n} = +\mathbf{k}$). Thus $Q = \epsilon_0 AV/d$ and the capacitance is $C = \epsilon_0 A/d$. The energy stored is $CV^2/2 = \epsilon_0 AV^2/(2d) = (1/2)\epsilon_0 Ad \mathbf{E}^2$, in agreement with (2.29) (since \mathbf{E}^2 is constant and Ad is the volume of the capacitor).

Actually, allowing for the non-zero thickness of the plates, what we calculated here is only the charge on the *inner* surface of the each plate, i.e., the surface nearest the other plate. The total charge on each plate is slightly larger because there will also be some charge on the outer surface. So the capacitance will be larger than calculated above. But the above result is a good approximation when d is small compared to the size of the plates (the calculation becomes exact in the limit of infinite plates).

Example 3. Consider a point charge Q held at distance d outside the surface S of a conductor which is held at potential V . Assume that d is much smaller than the

radius of curvature of S , so if we are only interested in the behaviour near Q then we can approximate S by an infinite plane. We take this plane to be $z = 0$ and take the position of the charge to be $(0, 0, d)$. We'll only consider the field in the region $z > 0$. We need to solve Poisson's equation for a point charge source

$$\nabla^2 \Phi = -\frac{Q}{\epsilon_0} \delta(x) \delta(y) \delta(z - d) \quad (2.63)$$

subject to the boundary conditions that Φ is constant on S (i.e. S must be an equipotential surface). You learnt how to do this using the method of images last term in Methods. We introduce a fictitious image charge $-Q$ at the point $(0, 0, -d)$ so that the solution in $z > 0$ is

$$\Phi = \frac{Q}{4\pi\epsilon_0 \sqrt{x^2 + y^2 + (z - d)^2}} - \frac{Q}{4\pi\epsilon_0 \sqrt{x^2 + y^2 + (z + d)^2}} + V \quad (2.64)$$

We've also added the constant V to the solution. Clearly this is a solution of Poisson's equation in $z > 0$ and it obeys $\Phi = V$ on S . So this is the solution to our problem. Note that we cannot impose $\Phi = 0$ at infinity. This is an artefact of the planar approximation, which makes the conductor infinitely extended. See Fig. 5 for a sketch of the electric field and equipotential lines. To calculate the surface charge we consider

$$E_z = -\frac{\partial \Phi}{\partial z} = \frac{Q(z - d)}{4\pi\epsilon_0 (x^2 + y^2 + (z - d)^2)^{3/2}} - \frac{Q(z + d)}{4\pi\epsilon_0 (x^2 + y^2 + (z + d)^2)^{3/2}} \quad (2.65)$$

Evaluating this at $z = 0$ should give σ/ϵ_0 (from (2.60)), so we have

$$\sigma = -\frac{Qd}{2\pi (x^2 + y^2 + d^2)^{3/2}} \quad (2.66)$$

So σ is negative near a positive charge Q , as expected.

2.6 Electric dipoles and the multipole expansion

Consider a charge distribution contained inside a finite region V . We choose our coordinates \mathbf{x} so that V is contained within a ball of radius d centred on the origin. The potential given by (2.15) is

$$\Phi(\mathbf{x}) = \frac{1}{4\pi\epsilon_0} \int_V \frac{\rho(\mathbf{x}')}{|\mathbf{x} - \mathbf{x}'|} d^3 \mathbf{x}' \quad (2.67)$$

Let's now investigate the behaviour of Φ far away from V . We assume

$$|\mathbf{x}| \gg d \quad (2.68)$$

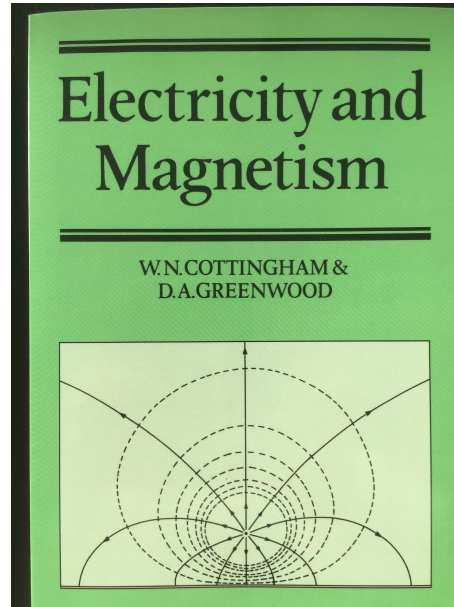

Figure 5. Electric field lines (solid) and equipotential lines (dashed) for a point charge near the surface of a conductor. Here the y coordinate is suppressed and the z coordinate is vertical. Do judge a book by its cover.

Inside the integral we have

$$\begin{aligned} |\mathbf{x} - \mathbf{x}'|^{-1} &= [(\mathbf{x} - \mathbf{x}')^2]^{-1/2} = (\mathbf{x}^2 - 2\mathbf{x} \cdot \mathbf{x}' + \mathbf{x}'^2)^{-1/2} \\ &= \frac{1}{|\mathbf{x}|} \left[1 - 2\frac{\hat{\mathbf{x}} \cdot \mathbf{x}'}{|\mathbf{x}|} + \mathcal{O}\left(\frac{d^2}{|\mathbf{x}^2}\right) \right]^{-1/2} = \frac{1}{|\mathbf{x}|} + \frac{\hat{\mathbf{x}} \cdot \mathbf{x}'}{|\mathbf{x}|^2} + \mathcal{O}\left(\frac{d^2}{|\mathbf{x}|^3}\right) \end{aligned} \quad (2.69)$$

where $\hat{\mathbf{x}} = \mathbf{x}/|\mathbf{x}|$. On the second line we used the fact that $\mathbf{x}' \in V$ so $|\mathbf{x}'| < d$, and the binomial theorem. Substituting into the integral we obtain

$$\Phi = \frac{1}{4\pi\epsilon_0} \left[\frac{Q}{|\mathbf{x}|} + \frac{\hat{\mathbf{x}} \cdot \mathbf{p}}{|\mathbf{x}|^2} + \mathcal{O}\left(\frac{|\rho|_\infty d^5}{|\mathbf{x}|^3}\right) \right] \quad (2.70)$$

where $|\rho|_\infty$ is the maximum value of $|\rho|$, Q is the total charge (1.6) and \mathbf{p} is the *dipole moment* of the charge distribution defined by

$$\mathbf{p} = \int_V \mathbf{x}\rho(\mathbf{x})d^3\mathbf{x} \quad (2.71)$$

On examples sheet 1 you are asked to calculate the next term in the large $|\mathbf{x}|$ expansion (2.70). The result is

$$\frac{Q_{ij}\hat{x}_i\hat{x}_j}{2|\mathbf{x}|^3} \quad (2.72)$$

where Q_{ij} is the *quadrupole moment* tensor of the charge distribution defined by

$$Q_{ij} = \int_V (3x_i x_j - \delta_{ij} \mathbf{x}^2) \rho(\mathbf{x}) d^3 \mathbf{x} \quad (2.73)$$

One can continue this *multipole expansion* to arbitrarily high order in $1/|\mathbf{x}|$ with higher rank tensors appearing at each order. We have written the definition of \mathbf{p} and Q_{ij} for a time-independent ρ (since we're doing electrostatics) but the same definitions apply in the time-dependent case, for which \mathbf{p} and Q_{ij} are functions of t .

The expansion (2.70) shows that the leading behaviour of the field far from the source is the same as for a point charge Q at the origin. However, we are often interested in electrically neutral matter, for which the total charge Q is zero. In this case, it is the dipole moment \mathbf{p} which determines the leading behaviour of the field. Note that if we translate the origin by setting $\mathbf{x}' = \mathbf{x} - \mathbf{a}$ then the dipole moment changes to $\mathbf{p}' = \mathbf{p} - Q\mathbf{a}$. So only when $Q = 0$ is the definition of \mathbf{p} independent of the choice of origin.

Just as it is convenient to think about point charges, it is sometimes useful to think about point dipoles. This is useful for describing molecules, such as water, which have zero charge but a non-zero dipole moment. To do this, consider the field of a pair of equal and opposite point charges with positions $\pm\mathbf{a}/2$:

$$\Phi = \frac{q}{4\pi\epsilon_0} \left(\frac{1}{|\mathbf{x} - \mathbf{a}/2|} - \frac{1}{|\mathbf{x} + \mathbf{a}/2|} \right) \quad (2.74)$$

Now let $\mathbf{a} \rightarrow 0$ with $\mathbf{p} \equiv q\mathbf{a}$ fixed. The result is (using (2.69) with $\mathbf{x}' = \pm\mathbf{a}/2$)

$$\Phi_{\text{dipole}} = \frac{\hat{\mathbf{x}} \cdot \mathbf{p}}{4\pi\epsilon_0 |\mathbf{x}|^2} \quad (2.75)$$

Thus this limiting process gives the dipole field. Calculating $\mathbf{E} = -\nabla\Phi$ gives

$$\mathbf{E}_{\text{dipole}} = \frac{3(\hat{\mathbf{x}} \cdot \mathbf{p})\hat{\mathbf{x}} - \mathbf{p}}{4\pi\epsilon_0 |\mathbf{x}|^3} \quad (2.76)$$

This electric field is sketched in Fig. 6.

Let's determine the charge density that gives rise to this field. Before taking the limit the charge distribution is

$$\rho(\mathbf{x}) = q\delta^{(3)}(\mathbf{x} - \mathbf{a}/2) - q\delta^{(3)}(\mathbf{x} + \mathbf{a}/2). \quad (2.77)$$

We now Taylor expand the delta function for small \mathbf{a} ²⁰

$$\rho(\mathbf{x}) = -\frac{q}{2}\mathbf{a} \cdot \nabla\delta^{(3)}(\mathbf{x}) - \frac{q}{2}\mathbf{a} \cdot \nabla\delta^{(3)}(\mathbf{x}) + \dots \quad (2.78)$$

²⁰More properly we should integrate against a test function and then Taylor expand.

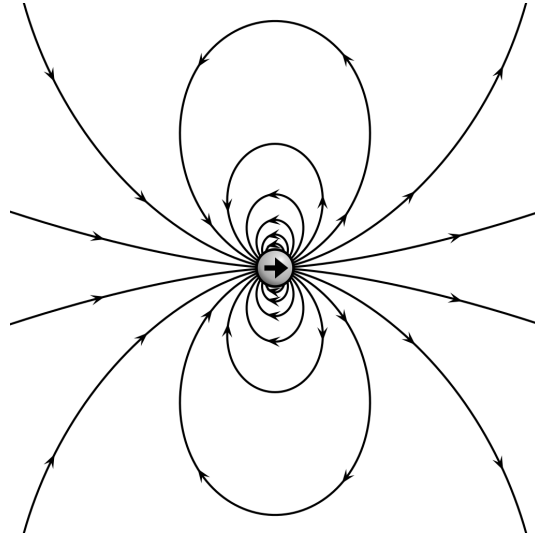

Figure 6. Electric field lines of a point dipole at the origin. The dipole moment \mathbf{p} is in the x -direction, as shown by the big arrow. (Source: Wikipedia)

So taking the limit $\mathbf{a} \rightarrow 0$ with \mathbf{p} fixed we obtain the charge density of a point dipole

$$\rho_{\text{dipole}}(\mathbf{x}) = -\mathbf{p} \cdot \nabla \delta^{(3)}(\mathbf{x}) \quad (2.79)$$

You can check that inserting this into (2.15) reproduces (2.75).

Finally we will consider the effect of an *external* electrostatic field on a charge distribution supported in V . By the superposition principle we can write $\mathbf{E} = \mathbf{E}_{\text{self}} + \mathbf{E}_{\text{ext}}$ where \mathbf{E}_{self} is the field produced by the distribution itself. As discussed above, the force and torque exerted by a charge distribution on itself are zero. Therefore we need only consider the effect of the external field \mathbf{E}_{ext} . Henceforth we'll drop the subscript "ext" and call this external field \mathbf{E} . Consider first the torque. From (1.17) we have

$$\boldsymbol{\tau} = \int_V d^3\mathbf{x} \rho(\mathbf{x}) \mathbf{x} \times \mathbf{E}(\mathbf{x}) \quad (2.80)$$

As above, we choose our origin to lie within V . We now assume that V is small compared to the scale over which \mathbf{E} varies. We can then approximate \mathbf{E} by its Taylor expansion about the origin:

$$E_i(\mathbf{x}) = E_i(0) + x_j \partial_j E_i(0) + \dots \quad (2.81)$$

To calculate the torque, we substitute this into (2.80) and retain just the leading term, which gives

$$\boldsymbol{\tau} \approx \mathbf{p} \times \mathbf{E}(0) \quad (2.82)$$

This formula is exact for a point dipole at the origin, as can be seen by substituting (2.79) into (2.80). Note that the torque vanishes if, and only if, \mathbf{p} is either aligned or anti-aligned with \mathbf{E} . So these correspond to equilibrium configurations of the dipole. In the aligned case if one perturbs \mathbf{p} slightly then the torque acts to return \mathbf{p} to alignment, so the equilibrium is stable. In the anti-aligned case it is unstable.²¹

To calculate the force we substitute (2.81) into (1.16):

$$\begin{aligned} F_i &= \int_V d^3\mathbf{x} \rho(\mathbf{x}) E_i(\mathbf{x}) = \int_V d^3\mathbf{x} \rho(\mathbf{x}) (E_i(0) + x_j \partial_j E_i(0) + \dots) \\ &\approx Q E_i(0) + p_j \partial_j E_i(0) \end{aligned} \quad (2.83)$$

Thus, to leading order, the force is the same as that of a test body of charge Q . However, if the total charge vanishes (as is the case for normal matter), then the leading order term arises from the dipole moment and can be written

$$\mathbf{F}_{\text{dipole}} = \mathbf{p} \cdot \nabla \mathbf{E}(0) = \nabla(\mathbf{p} \cdot \mathbf{E})(0) \quad (2.84)$$

The second equality follows from $\nabla \times \mathbf{E} = 0$ which implies $\partial_i E_j - \partial_j E_i = 0$ so $p_j \partial_j E_i = p_j \partial_i E_j = \partial_i(p_j E_j)$. (2.84) is exact for a point dipole.

Since the force is the gradient of a scalar, we interpret this scalar as minus the potential energy of the dipole. Thus, for a dipole at an arbitrary point \mathbf{x} the potential energy is

$$V_{\text{dipole}}(\mathbf{x}) = -\mathbf{p} \cdot \mathbf{E}(\mathbf{x}) \quad (2.85)$$

(This result can also be derived by viewing the dipole as the limit of a pair of point charges by calculating the limit of the potential energy of the charges.) Note that this is minimized when \mathbf{p} is aligned with $\mathbf{E}(\mathbf{x})$.

3 Magnetostatics

3.1 Ampère's law

Magnetostatics is the study of time-independent magnetic fields produced by time-independent currents. The fields $\mathbf{B}(\mathbf{x})$ and $\mathbf{J}(\mathbf{x})$ are governed by three equations. The charge conservation equation (1.10) reduces to

$$\nabla \cdot \mathbf{J} = 0 \quad (3.1)$$

²¹To justify these statements we'd need to specify how the dipole responds to a torque. This would involve discussing its inertia tensor, angular velocity etc.

The non-trivial Maxwell equations are (M2)

$$\nabla \cdot \mathbf{B} = 0 \quad (3.2)$$

and (M4), which reduces to

$$\nabla \times \mathbf{B} = \mu_0 \mathbf{J}. \quad (3.3)$$

Using Stokes' theorem it can be expressed in integral form as

$$\int_C \mathbf{B} \cdot d\mathbf{x} = \mu_0 \int_S \mathbf{J} \cdot d\mathbf{S} \equiv \mu_0 I[S] \quad (3.4)$$

where S is a surface spanning a closed curve C . Here $I[S]$ is the current across S , defined in (1.5). This equation is called *Ampère's law*. (Sometimes (3.3) is also called Ampère's law.) It lets us determine the magnetic field produced by simple current distributions.

Example. Consider a current density given in cylindrical polar coordinates (r, ϕ, z) by $\mathbf{J} = j(r)\mathbf{e}_z$ with $j(r) = 0$ for $r > R$ (this satisfies (3.1)). Take $S = D_r$, a disc of radius r centered on the z -axis. The RHS of Ampère's law is non-zero. For the LHS to be non-zero then we need $B_\phi \neq 0$. Motivated by symmetry, we assume that $\mathbf{B} = B(r)\mathbf{e}_\phi$. Ampère's law gives

$$2\pi r B(r) = \mu_0 I(r) \quad (3.5)$$

where

$$I(r) = \int_{D_r} j dS = 2\pi \int_0^r r' j(r') dr'. \quad (3.6)$$

Hence we have

$$\mathbf{B} = \frac{\mu_0 I(r)}{2\pi r} \mathbf{e}_\phi = \frac{\mu_0 I(r)(-y, x, 0)}{2\pi(x^2 + y^2)} \quad (3.7)$$

The second expression follows from converting to Cartesian coordinates using $\mathbf{e}_\phi = \mathbf{h}_\phi/|\mathbf{h}_\phi|$ where $\mathbf{h}_\phi = \partial\mathbf{x}/\partial\phi$. One can now check that this \mathbf{B} satisfies equations (M2) and (3.3) (Exercise) so we have solved the problem. Note that for $r > R$ we have $I(r) = I(R) \equiv I$ so

$$\mathbf{B} = \frac{\mu_0 I}{2\pi r} \mathbf{e}_\phi \quad (3.8)$$

An important application of this result is the case of a thin wire oriented along the z -axis and carrying current I . We can obtain the solution in this case by taking the limit $R \rightarrow 0$. The magnetic field outside the wire is then given by (3.8).

Equation (3.1) implies that the current is the same for any cross-section of a conducting wire. To see this, consider a wire made of conducting material, in the shape

of a tube, carrying some time-independent current density \mathbf{J} . We assume that there is no conducting material outside the wire, so \mathbf{J} vanishes outside the wire. Hence, by continuity, \mathbf{J} vanishes at the edges of the tube. Let S_1 and S_2 be two cross-sections of the wire. Applying the divergence theorem to the region V of the tube between S_1 and S_2 gives

$$I[S_1] - I[S_2] = \int_V \nabla \cdot \mathbf{J} dV = 0 \quad (3.9)$$

where the minus sign on the LHS arises because we choose the normals of S_1 and S_2 to point along the wire. This shows that the current I is the same for any cross-section of the wire.

3.2 Vector potential

In a topologically trivial²² region, (M2) implies that there exists a vector field $\mathbf{A}(\mathbf{x})$ such that

$$\mathbf{B} = \nabla \times \mathbf{A} \quad (3.10)$$

\mathbf{A} is called the *vector potential*. If \mathbf{A} satisfies this equation then so does $\mathbf{A} + \nabla\lambda$ for any function $\lambda(\mathbf{x})$ so the vector potential is not uniquely defined by this equation. A map of the form $\mathbf{A} \rightarrow \mathbf{A} + \nabla\lambda$ is called a *gauge transformation* and we say that the definition of \mathbf{A} exhibits “gauge freedom”.

The gauge freedom can be eliminated by imposing an extra condition on \mathbf{A} , referred to as a *gauge condition*. The most common gauge condition is *Coulomb gauge* defined by

$$\nabla \cdot \mathbf{A} = 0 \quad (3.11)$$

We can always achieve this condition using a gauge transformation. To see this, let \mathbf{A} be a vector potential and let $\mathbf{A}' = \mathbf{A} + \nabla\lambda$ be related by a gauge transformation. Then

$$\nabla \cdot \mathbf{A}' = \nabla \cdot \mathbf{A} + \nabla^2\lambda \quad (3.12)$$

Choose λ to solve the Poisson equation $\nabla^2\lambda = -\nabla \cdot \mathbf{A}$. We now have $\nabla \cdot \mathbf{A}' = 0$ so the new vector potential satisfies the Coulomb gauge condition.

Substituting the definition (3.10) into Ampère’s law gives

$$\mu_0\mathbf{J} = \nabla \times (\nabla \times \mathbf{A}) = \nabla(\nabla \cdot \mathbf{A}) - \nabla^2\mathbf{A} \quad (3.13)$$

Hence in Coulomb gauge we have

$$\nabla^2\mathbf{A} = -\mu_0\mathbf{J} \quad (3.14)$$

²²More precisely: this holds in a region V that is *contractible*. This means that there exists a smooth function $f : V \times [0, 1] \rightarrow V$ such that $f(\mathbf{x}, 0) = \mathbf{x}$ and $f(\mathbf{x}, 1) = \mathbf{x}_0$ for some $\mathbf{x}_0 \in V$. In words, “ V can be smoothly deformed to a point”.

so each component of \mathbf{A} satisfies Poisson's equation. If we are solving this equation on \mathbb{R}^3 then we can immediately write down the solution (compare (2.15))

$$\mathbf{A}(\mathbf{x}) = \int \frac{\mu_0 \mathbf{J}(\mathbf{x}')}{4\pi |\mathbf{x} - \mathbf{x}'|} d^3 \mathbf{x}' \quad (3.15)$$

Here we have assumed that $\mathbf{J}(\mathbf{x})$ decays sufficiently rapidly at infinity so that the integral converges, and that $\mathbf{A} \rightarrow 0$ at infinity.

We need to check that (3.15) satisfies the Coulomb gauge condition that we assumed in its derivation:

$$\begin{aligned} \nabla \cdot \mathbf{A} &= \frac{\mu_0}{4\pi} \int \mathbf{J}(\mathbf{x}') \cdot \nabla \frac{1}{|\mathbf{x} - \mathbf{x}'|} d^3 \mathbf{x}' = \frac{\mu_0}{4\pi} \int \mathbf{J}(\mathbf{x}') \cdot \left(-\nabla' \frac{1}{|\mathbf{x} - \mathbf{x}'|} \right) d^3 \mathbf{x}' \\ &= \frac{\mu_0}{4\pi} \int \left[-\nabla' \cdot \left(\frac{\mathbf{J}(\mathbf{x}')}{|\mathbf{x} - \mathbf{x}'|} \right) + \frac{\nabla' \cdot \mathbf{J}(\mathbf{x}')}{|\mathbf{x} - \mathbf{x}'|} \right] d^3 \mathbf{x}' = 0 \end{aligned} \quad (3.16)$$

In the second equality we have used $\nabla(f(\mathbf{x} - \mathbf{x}')) = -\nabla'(f(\mathbf{x} - \mathbf{x}'))$ where ∇' is the gradient w.r.t. \mathbf{x}' . The final equality follows from current conservation (3.1) and the fact that the first term in the integral is a divergence which can be converted to a surface term at infinity and this vanishes because \mathbf{J} vanishes at infinity.

Finally we can use (3.10) to calculate the magnetic field arising from the current distribution \mathbf{J} :

$$\begin{aligned} B_i &= \epsilon_{ijk} \partial_j A_k = \frac{\mu_0}{4\pi} \epsilon_{ijk} \int J_k(\mathbf{x}') \partial_j \frac{1}{|\mathbf{x} - \mathbf{x}'|} d^3 \mathbf{x}' = -\frac{\mu_0}{4\pi} \epsilon_{ijk} \int J_k(\mathbf{x}') \frac{x_j - x'_j}{|\mathbf{x} - \mathbf{x}'|^3} d^3 \mathbf{x}' \\ &= \frac{\mu_0}{4\pi} \epsilon_{ikj} \int J_k(\mathbf{x}') \frac{x_j - x'_j}{|\mathbf{x} - \mathbf{x}'|^3} d^3 \mathbf{x}' \end{aligned} \quad (3.17)$$

hence

$$\mathbf{B}(\mathbf{x}) = \int \frac{\mu_0 \mathbf{J}(\mathbf{x}') \times (\mathbf{x} - \mathbf{x}')}{4\pi |\mathbf{x} - \mathbf{x}'|^3} d^3 \mathbf{x}'. \quad (3.18)$$

This provides the solution to any problem in magnetostatics involving a current density defined on \mathbb{R}^3 and vanishing at infinity. Note that the integrand of (3.18) decays faster than that of (3.15) and so the integral in (3.18) converges under milder assumptions about the decay of \mathbf{J} than are required to obtain the solution (3.15).

3.3 Biot-Savart law

Now we turn to thin wires. We want to apply the solution (3.18) to determine the magnetic field produced by a thin wire carrying a time-independent current I . To do this we first need to discuss the current density of such a wire. Let the wire lie along

some curve C . Clearly \mathbf{J} vanishes outside the wire so it must involve something like a delta function which is non-zero only on C . The simplest thing we can write down is

$$\mathbf{J}(\mathbf{x}) = I \int_C d\mathbf{x}' \delta^{(3)}(\mathbf{x} - \mathbf{x}') \quad (3.19)$$

Let's check that this has the desired properties. First it needs to satisfy the conservation law (3.1). So we calculate

$$\begin{aligned} \nabla \cdot \mathbf{J}(\mathbf{x}) &= I \int_C d\mathbf{x}' \cdot \nabla \delta^{(3)}(\mathbf{x} - \mathbf{x}') = I \int_C d\mathbf{x}' \cdot [-\nabla' \delta^{(3)}(\mathbf{x} - \mathbf{x}')] \\ &= -I [\delta^{(3)}(\mathbf{x} - \mathbf{x}_2) - \delta^{(3)}(\mathbf{x} - \mathbf{x}_1)] \end{aligned} \quad (3.20)$$

where C runs from \mathbf{x}_1 to \mathbf{x}_2 . If C is a *closed* curve then $\mathbf{x}_1 = \mathbf{x}_2$ and so the RHS vanishes. Similarly, if C starts and ends at infinity then \mathbf{x}_1 and \mathbf{x}_2 are infinite so the delta functions in the final expression above are zero for finite \mathbf{x} . So in these cases $\nabla \cdot \mathbf{J} = 0$ as required.²³

Next let's check that (3.19) does indeed give a current I across a surface S that intersects the wire once. Let S be a small disc which intersects C orthogonally at some point \mathbf{x}_0 , i.e., the normal \mathbf{n} to S is tangent to C at \mathbf{x}_0 . We then have

$$\int_S \mathbf{J} \cdot d\mathbf{S} = I \int_S \int_C d\mathbf{S} \cdot d\mathbf{x}' \delta^{(3)}(\mathbf{x} - \mathbf{x}') \quad (3.21)$$

Here \mathbf{x} lies on S and \mathbf{x}' on C . Since S intersects C only at \mathbf{x}_0 , the delta-function is non-zero only at $\mathbf{x} = \mathbf{x}' = \mathbf{x}_0$. Hence we are free to replace to integral over C by an integral over an arbitrarily small section C' of C that includes \mathbf{x}_0 . Similarly we are free to replace S by an arbitrarily tiny subsection S' of S as long as this includes the point \mathbf{x}_0 . Since C' and S' are arbitrarily small, their curvature can be neglected. We can choose coordinates so that C' is along the z -axis and S' in the xy -plane, with \mathbf{x}_0 the origin. We then have $d\mathbf{S} = dx dy \mathbf{k}$ and $d\mathbf{x}' = dz \mathbf{k}$ so the integral reduces to

$$I \int_{S'} \int_{C'} dx dy dz \delta^{(3)}((x, y, 0) - (0, 0, z)) = I \int_{S'} \int_{C'} dx dy dz \delta(x) \delta(y) \delta(-z) = I \quad (3.22)$$

Thus (3.19) does indeed describe a current I along the curve C .

We can now substitute (3.19) into (3.15) to obtain the vector potential and magnetic field produced by a thin wire:

$$\mathbf{A}(\mathbf{x}) = \frac{\mu_0 I}{4\pi} \int d^3 \mathbf{x}'' \frac{1}{|\mathbf{x} - \mathbf{x}''|} \int_C d\mathbf{x}' \delta^{(3)}(\mathbf{x}'' - \mathbf{x}') = \frac{\mu_0 I}{4\pi} \int_C \frac{d\mathbf{x}'}{|\mathbf{x} - \mathbf{x}'|} \quad (3.23)$$

²³If C has finite endpoints then $\nabla \cdot \mathbf{J} \neq 0$. This is to be expected: if the wire has ends then current would be flowing in/out of these ends and so we'd have to allow \mathbf{J} to be non-zero away from C .

In the first step we replaced the dummy variable \mathbf{x}' with \mathbf{x}'' in (3.15). The corresponding magnetic field can be obtained either by taking the curl of this expression (as we did to obtain (3.18)) or by substituting (3.19) into (3.18). The result is

$$\mathbf{B}(\mathbf{x}) = \frac{\mu_0 I}{4\pi} \int_C \frac{d\mathbf{x}' \times (\mathbf{x} - \mathbf{x}')}{|\mathbf{x} - \mathbf{x}'|^3} \quad (3.24)$$

This expression is known as the *Biot-Savart law*. You will use it to calculate \mathbf{B} for some simple examples on examples sheet 2.

3.4 The force on a current distribution

Consider two thin wires carrying currents I_1 and I_2 along curves C_1 and C_2 . By the superposition principle, the magnetic field is $\mathbf{B} = \mathbf{B}_1 + \mathbf{B}_2$ where \mathbf{B}_i is the magnetic field produced by the i th wire. The magnetic field produced by each wire exerts a force on the other wire. (This force will need to be cancelled by an external force to keep the system static.) To calculate this force, we substitute (3.19) into the Lorentz force law to obtain the force exerted on wire 1 by wire 2:

$$\begin{aligned} \mathbf{F}_{12} &= \int d^3\mathbf{x} \mathbf{J}_1(\mathbf{x}) \times \mathbf{B}_2(\mathbf{x}) = \int d^3\mathbf{x} I_1 \int_{C_1} d\mathbf{x}_1 \times \mathbf{B}_2(\mathbf{x}) \delta^{(3)}(\mathbf{x} - \mathbf{x}_1) \\ &= I_1 \int_{C_1} d\mathbf{x}_1 \times \mathbf{B}_2(\mathbf{x}_1) \end{aligned} \quad (3.25)$$

Example. Consider two infinite straight parallel thin wires separated by a distance r . In this case, the force is infinite because the wires are infinite. So let's calculate the force on a section of the first wire of length L . Choose axes so that the second wire is along the z -axis. Let C_1 be a segment of wire 1 with length L , say $z \in [z_0, z_0 + L]$. In this case we know \mathbf{B}_2 from (3.8). Using cylindrical polars and setting $d\mathbf{x}_1 = \mathbf{e}_z dz$ this gives

$$\mathbf{F}_{12} = I_1 \int_{z_0}^{z_0+L} dz \mathbf{e}_z \times \left(\frac{\mu_0 I_2}{2\pi r} \mathbf{e}_\phi \right) = -\frac{\mu_0 I_1 I_2 L}{2\pi r} \mathbf{e}_r \quad (3.26)$$

Thus the force on wire 1 is directed radially (i.e. towards wire 2) and has magnitude $\mu_0 I_1 I_2 / (2\pi r)$ per unit length. The force is attractive (repulsive) if I_1 and I_2 have the same (opposite) sign.

In general, we can use the Biot-Savart law to determine \mathbf{B}_2 in (3.25) and the result can be brought to the form (examples sheet 2)

$$\mathbf{F}_{12} = -\frac{\mu_0 I_1 I_2}{4\pi} \int_{C_1} \int_{C_2} d\mathbf{x}_1 \cdot d\mathbf{x}_2 \frac{(\mathbf{x}_1 - \mathbf{x}_2)}{|\mathbf{x}_1 - \mathbf{x}_2|^3} \quad (3.27)$$

Below we'll derive this formula as the limit of the corresponding result for thick wires. Note that the result is antisymmetric under interchange of the labels 1 and 2 hence it obeys Newton's third law, i.e., the force on wire 2 due to wire 1 is $\mathbf{F}_{21} = -\mathbf{F}_{12}$.

Note that we could also consider the force exerted on wire 1 by its own magnetic field (the "self-force") by replacing \mathbf{B}_2 by \mathbf{B}_1 in (3.25). The integrand is singular in this case which makes the result ambiguous. However, by considering thick wires (below) we'll show that this self-force always vanishes.

Let's now consider the case of two *thick* wires carrying time-independent current densities \mathbf{J}_1 and \mathbf{J}_2 and occupying regions V_1 and V_2 . Let \mathbf{B}_i be the magnetic field produced by current density \mathbf{J}_i , as given by (3.18). Then the force exerted by the second wire on the first is given by the Lorentz force law (1.16) as

$$\mathbf{F}_{12} = \int_{V_1} d^3\mathbf{x}_1 \mathbf{J}_1(\mathbf{x}_1) \times \mathbf{B}_2(\mathbf{x}_1) = \frac{\mu_0}{4\pi} \int_{V_1} \int_{V_2} d^3\mathbf{x}_1 d^3\mathbf{x}_2 \frac{\mathbf{J}_1(\mathbf{x}_1) \times [\mathbf{J}_2(\mathbf{x}_2) \times (\mathbf{x}_1 - \mathbf{x}_2)]}{|\mathbf{x}_1 - \mathbf{x}_2|^3} \quad (3.28)$$

where we used (3.18) in the second expression. We now use the identity $\mathbf{a} \times (\mathbf{b} \times \mathbf{c}) = (\mathbf{a} \cdot \mathbf{c})\mathbf{b} - (\mathbf{a} \cdot \mathbf{b})\mathbf{c}$ to obtain

$$\mathbf{F}_{12} = \frac{\mu_0}{4\pi} \int_{V_1} \int_{V_2} d^3\mathbf{x}_1 d^3\mathbf{x}_2 \left[\frac{\mathbf{J}_1(\mathbf{x}_1) \cdot (\mathbf{x}_1 - \mathbf{x}_2) \mathbf{J}_2(\mathbf{x}_2)}{|\mathbf{x}_1 - \mathbf{x}_2|^3} - \frac{\mathbf{J}_1(\mathbf{x}_1) \cdot \mathbf{J}_2(\mathbf{x}_2) (\mathbf{x}_1 - \mathbf{x}_2)}{|\mathbf{x}_1 - \mathbf{x}_2|^3} \right] \quad (3.29)$$

The first term involves the following integral over \mathbf{x}_1 :

$$\begin{aligned} \int_{V_1} d^3\mathbf{x}_1 \frac{\mathbf{J}_1(\mathbf{x}_1) \cdot (\mathbf{x}_1 - \mathbf{x}_2)}{|\mathbf{x}_1 - \mathbf{x}_2|^3} &= - \int_{V_1} d^3\mathbf{x}_1 \mathbf{J}_1(\mathbf{x}_1) \cdot \nabla_1 \frac{1}{|\mathbf{x}_1 - \mathbf{x}_2|} \\ &= \int_{V_1} d^3\mathbf{x}_1 \left[-\nabla_1 \cdot \left(\frac{\mathbf{J}_1(\mathbf{x}_1)}{|\mathbf{x}_1 - \mathbf{x}_2|} \right) + \frac{\nabla_1 \cdot \mathbf{J}_1(\mathbf{x}_1)}{|\mathbf{x}_1 - \mathbf{x}_2|} \right] \end{aligned} \quad (3.30)$$

where ∇_1 is the derivative w.r.t. \mathbf{x}_1 . Assume that our two wires do not intersect. Then $\mathbf{x}_1 \notin V_1$ because $\mathbf{x}_2 \in V_2$. Hence the integrand above is non-singular. The first term is a divergence so we can convert it to a surface term via the divergence theorem. This surface term vanishes because \mathbf{J}_1 vanishes on the surface of V_1 (by continuity). The second term in the integrand vanishes because \mathbf{J}_1 satisfies the conservation equation (3.1). Hence the integral (3.30) vanishes. This implies that the force on the first wire due to the second wire is

$$\mathbf{F}_{12} = -\frac{\mu_0}{4\pi} \int_{V_1} \int_{V_2} d^3\mathbf{x}_1 d^3\mathbf{x}_2 \frac{\mathbf{J}_1(\mathbf{x}_1) \cdot \mathbf{J}_2(\mathbf{x}_2) (\mathbf{x}_1 - \mathbf{x}_2)}{|\mathbf{x}_1 - \mathbf{x}_2|^3} \quad (3.31)$$

Note the similarity with (2.17) for the force between two charge distributions in electrostatics. As above, the result is antisymmetric under interchange of the labels 1 and

2 so Newton's third law is obeyed. Furthermore, we can calculate the force exerted by a wire occupying region V and carrying current \mathbf{j} on *itself* by setting $V_1 = V_2 = V$ and $\mathbf{J}_1 = \mathbf{J}_2 = \mathbf{J}$ in (3.31). The resulting integrand is antisymmetric in \mathbf{x}_1 and \mathbf{x}_2 hence this self-force vanishes.²⁴

Since $\mathbf{x}_1 - \mathbf{x}_2$ is a vector pointing from the second wire to the first wire, we see that if $\mathbf{J}_1(\mathbf{x}_1) \cdot \mathbf{J}_2(\mathbf{x}_2)$ is positive (negative) then the contribution to \mathbf{F}_{12} from the points $(\mathbf{x}_1, \mathbf{x}_2)$ describes an attractive (repulsive) force. So, roughly speaking, there is an attractive (repulsive) force between currents flowing in the same (opposite) direction, just as we found for the case of parallel thin wires.

Let's now specialize (3.31) to the case of two *thin* wires. To do this we note that, since \mathbf{J}_i vanishes outside V_i we can replace the region of integration V_i with \mathbb{R}^3 in (3.31). We then substitute (3.19) to obtain

$$\begin{aligned}\mathbf{F}_{12} &= -\frac{\mu_0 I_1 I_2}{4\pi} \int d^3 \mathbf{x}_1 \int d^3 \mathbf{x}_2 \frac{(\mathbf{x}_1 - \mathbf{x}_2)}{|\mathbf{x}_1 - \mathbf{x}_2|^3} \int_{C_1} \int_{C_2} d\mathbf{x}'_1 \cdot d\mathbf{x}'_2 \delta^{(3)}(\mathbf{x}_1 - \mathbf{x}'_1) \delta^{(3)}(\mathbf{x}_2 - \mathbf{x}'_2) \\ &= -\frac{\mu_0 I_1 I_2}{4\pi} \int_{C_1} \int_{C_2} d\mathbf{x}'_1 \cdot d\mathbf{x}'_2 \frac{(\mathbf{x}'_1 - \mathbf{x}'_2)}{|\mathbf{x}'_1 - \mathbf{x}'_2|^3}\end{aligned}\quad (3.32)$$

where the final equality follows from the definition of the delta function. Thus we have derived (3.27).

3.5 Surface currents

Just as we defined surface charge, we can also define surface *currents*. Consider a surface S to which charge is confined. The surface current density $\mathbf{K}(t, \mathbf{x})$ is defined for $\mathbf{x} \in S$ to be a vector field tangent to S such that the charge per unit time crossing an infinitesimal curve within S with length $d\ell$ is $\mathbf{K} \cdot \mathbf{m} d\ell$ where \mathbf{m} is a unit vector tangent to S and normal to the curve.

We can now derive conditions for the behaviour of the magnetic field across S in the presence of a surface current. These are analogous to the conditions on the electric field in the presence of a surface charge, as discussed in section 2.5. As in that section, we'll consider the full Maxwell equations, allowing for time-dependence.

²⁴This is a bit too quick because our argument for the vanishing of (3.30) used $\mathbf{x}_2 \notin V_1$ which is no longer the case here. In the self-force case, the integrand of (3.30) is divergent at $\mathbf{x}_1 = \mathbf{x}_2$ but this divergence is integrable, i.e., the integral can still be defined as the limit as $\epsilon \rightarrow 0$ of the integral over V_ϵ where V_ϵ is V minus a ball of radius ϵ and centre \mathbf{x}_2 . In the divergence theorem we pick up an additional surface term from the boundary of this ball but this surface term vanishes as $\epsilon \rightarrow 0$ because the area of the ball scales as ϵ^2 which beats the $1/\epsilon$ coming from the divergent integrand. Hence the conclusion that (3.30) vanishes is still valid in the self-force case.

Consider the pill-box region δV obtained by translating a section δS of S a small distance ϵ slightly outside (δS_+) and slightly inside (δS_-) the surface S (as in Fig. 4). The boundary of δV is $\delta S_+ \cup \delta S_- \cup \Sigma$. Equation (M2) gives

$$\int_{\delta S_+ \cup \delta S_- \cup \Sigma} \mathbf{B} \cdot d\mathbf{S} = 0 \quad (3.33)$$

If we take $\epsilon \rightarrow 0$ then the contribution from Σ vanishes and we are left with

$$\int_{\delta S} (\mathbf{B}_+ - \mathbf{B}_-) \cdot d\mathbf{S} = 0 \quad (3.34)$$

where \mathbf{B}_\pm is the magnetic field just outside/inside S . Since δS is arbitrary, this implies

$$(\mathbf{B}_+ - \mathbf{B}_-) \cdot \mathbf{n} = 0 \quad (3.35)$$

i.e., the normal component of the magnetic field is continuous across S . To determine the behaviour of the tangential components, consider a rectangular contour C with two long sides of length L and two short sides of length h with $L \gg h$. Choose C to be small compared to the scale on which S is curved so that S appears locally planar. Orient C so that the long sides lie just outside and just inside S . Let S' be the rectangle with boundary C as in Fig. 3. From (M4) we have

$$\int_C \mathbf{B} \cdot d\mathbf{x} = \mu_0 I[S'] + \frac{1}{c^2} \int_{S'} \frac{\partial \mathbf{E}}{\partial t} \cdot d\mathbf{S} \quad (3.36)$$

where $I[S']$ is the current across S' . From the definition of the surface current this is

$$I[S'] = \int_{C_0} \mathbf{K} \cdot \mathbf{m} dl \quad (3.37)$$

where C_0 is the line of intersection of S and S' and \mathbf{m} is the unit normal to C_0 that is tangent to S and oriented in a right-handed sense w.r.t. C , as shown in Fig. 7. This can be written $\mathbf{m} = \mathbf{n} \times \mathbf{t}$ where \mathbf{t} is the unit tangent to C_0 . (We neglect any contribution from a bulk current \mathbf{J} because this will vanish when we take $h \rightarrow 0$.)

Now take the limit $h \rightarrow 0$. On the RHS of (3.36), assuming $\partial \mathbf{E} / \partial t$ is bounded, the integral over S' vanishes in this limit in which S' shrinks to a line. The LHS reduces to

$$\int_{C_0} (\mathbf{B}_+ - \mathbf{B}_-) \cdot d\mathbf{x} = \int_{C_0} (\mathbf{B}_+ - \mathbf{B}_-) \cdot \mathbf{t} dl \quad (3.38)$$

Hence we have

$$\int_{C_0} (\mathbf{B}_+ - \mathbf{B}_-) \cdot \mathbf{t} dl = \mu_0 \int_{C_0} \mathbf{K} \cdot (\mathbf{n} \times \mathbf{t}) dl \quad (3.39)$$

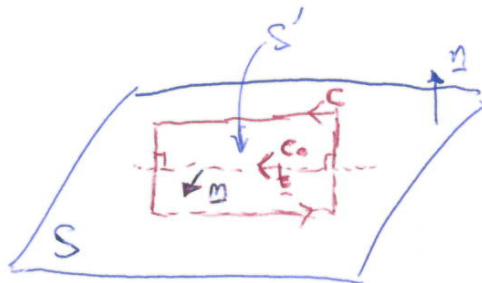

Figure 7. Direction of normal \mathbf{m} to C_0 within S .

Since C_0 is arbitrary, this gives

$$(\mathbf{B}_+ - \mathbf{B}_-) \cdot \mathbf{t} = \mu_0 \mathbf{K} \cdot (\mathbf{n} \times \mathbf{t}) = \mu_0 \mathbf{t} \cdot (\mathbf{K} \times \mathbf{n}) \quad (3.40)$$

where we used the cyclic symmetry of the triple scalar product. This equation says that the tangential components of \mathbf{B} have discontinuity $\mu_0 \mathbf{K} \times \mathbf{n}$ at S . Combining with the result from the normal component we have the final result

$$\mathbf{B}_+ - \mathbf{B}_- = \mu_0 \mathbf{K} \times \mathbf{n} \quad (3.41)$$

where \mathbf{n} points from the $-$ region to the $+$ region.

Example. Consider an infinite *solenoid* consisting of a cylinder of radius R with a thin wire carrying current I wound many times around its surface. Let N be the number of turns of the wire per unit length of the solenoid. We assume that there are so many turns of the wire that each turn can be treated as a circular current loop. Introducing cylindrical polar coordinates (r, ϕ, z) so that the cylinder is the surface $r = R$ we can describe the current in the wire as a surface current \mathbf{K} in the direction \mathbf{e}_ϕ . If we consider a small line interval $z_0 \leq z \leq z_0 + dz$ on the surface of the cylinder then the number of turns crossing this line is Ndz so the total current crossing the line interval is $INdz$. This implies that we have $\mathbf{K} = NI\mathbf{e}_\phi$. The outward normal to the solenoid is $\mathbf{n} = \mathbf{e}_r$ and so $\mathbf{K} \times \mathbf{n} = -NI\mathbf{e}_z$. Equation (3.41) now suggests that we should look for a solution in which \mathbf{B} is parallel to \mathbf{e}_z . We can write such a solution by inspection:

$$\mathbf{B} = \begin{cases} \mu_0 NI \mathbf{e}_z & r < R \\ 0 & r > R \end{cases} \quad (3.42)$$

Why is this a solution? \mathbf{B} has constant Cartesian components in both regions so it has vanishing divergence and curl and hence satisfies Maxwell's equations (with $\mathbf{E} = 0$) for

$r \neq R$. For $r = R$, we've shown that Maxwell's equations reduce to (3.41) and this equation is indeed satisfied by the above expression.²⁵

We've shown that the magnetic field vanishes outside the solenoid. Inside the solenoid, it is constant and directed along the axis of the solenoid. We derived this result for a cylindrical solenoid but the same result holds for a solenoid of arbitrary cross-section, i.e., a wire wrapped on the surface swept out by a simple closed curve translated in the z -direction. Maxwell's equations are satisfied as above, and (3.41) is also satisfied because $\mathbf{K} = NI\mathbf{t}$ where \mathbf{t} is the unit tangent to the wire, which implies that $\mathbf{K} \times \mathbf{n} = -NI\mathbf{e}_z$ as above (if the wire is wound anticlockwise).

3.6 Magnetic dipoles and the field far from a source

In section (2.6) we considered the electric field far from a charge density supported in some region V . Let's now consider the analogous problem in magnetostatics of determining the magnetic field far from a current density supported in a region V contained within a ball of radius d centred on the origin. Start from (3.15):

$$A_i(\mathbf{x}) = \int \frac{\mu_0 J_i(\mathbf{x}')}{4\pi|\mathbf{x} - \mathbf{x}'|} d^3\mathbf{x}' \quad (3.43)$$

This can be obtained from (2.67) via the substitutions $\Phi \rightarrow A_i$, $\rho \rightarrow J_i$ and $\epsilon_0 \rightarrow 1/\mu_0$. Thus we can immediately write down the solution for $|\mathbf{x}| \gg d$ by making the same substitutions in (2.70). The result is

$$A_i(\mathbf{x}) = \frac{\mu_0}{4\pi} \left[\frac{1}{|\mathbf{x}|} \int_V J_i(\mathbf{x}') d^3\mathbf{x}' + \frac{\hat{x}_j}{|\mathbf{x}|^2} \int_V x'_j J_i(\mathbf{x}') d^3\mathbf{x}' + \mathcal{O}\left(\frac{|\mathbf{J}|_\infty d^5}{|\mathbf{x}|^3}\right) \right] \quad (3.44)$$

where $\hat{\mathbf{x}} = \mathbf{x}/|\mathbf{x}|$ and $|\mathbf{J}|_\infty$ is the maximum value of $|\mathbf{J}|$. We can simplify the integrals here using the divergence theorem and current conservation. First we have

$$0 = \int_V d^3\mathbf{x} \partial_j (x_i J_j(\mathbf{x})) = \int_V d^3\mathbf{x} (\delta_{ij} J_j(\mathbf{x}) + x_i \partial_j J_j(\mathbf{x})) = \int_V d^3\mathbf{x} J_i(\mathbf{x}) \quad (3.45)$$

the first equality follows from the divergence theorem and the fact that \mathbf{J} vanishes on the boundary of V (by continuity). The final equality uses current conservation (3.1), i.e., $\partial_j J_j = 0$. We have shown that the first term in (3.44) vanishes. For the second term, consider

$$\begin{aligned} 0 &= \int_V d^3\mathbf{x} \partial_k (x_i x_j J_k(\mathbf{x})) = \int_V d^3\mathbf{x} (\delta_{ik} x_j J_k(\mathbf{x}) + \delta_{jk} x_i J_k(\mathbf{x}) + x_i x_j \partial_k J_k(\mathbf{x})) \\ &= \int_V d^3\mathbf{x} (x_j J_i(\mathbf{x}) + x_i J_j(\mathbf{x})) \end{aligned} \quad (3.46)$$

²⁵If you're not happy with this "by inspection" approach then a more systematic method would be to argue that (3.41), and symmetry, suggests the Ansatz $\mathbf{B} = B(r)\mathbf{e}_z$. Plugging into Maxwell's equations, solving, and demanding that $\mathbf{B} \rightarrow 0$ at infinity will reproduce the above solution.

Again the first equality follows from the divergence theorem and the final equality from current conservation. Using this result we have

$$\int_V d^3\mathbf{x} x_j J_i(\mathbf{x}) = \frac{1}{2} \int_V d^3\mathbf{x} (x_j J_i(\mathbf{x}) - x_i J_j(\mathbf{x})) = -\epsilon_{ijk} m_k \quad (3.47)$$

where the *magnetic dipole moment* of the current distribution is defined by

$$\mathbf{m} = \frac{1}{2} \int_V \mathbf{x} \times \mathbf{J}(\mathbf{x}) d^3\mathbf{x} \quad (3.48)$$

Substituting into (3.44) gives, for $|\mathbf{x}| \gg d$,

$$\mathbf{A}(\mathbf{x}) = \frac{\mu_0}{4\pi} \left[\frac{\mathbf{m} \times \hat{\mathbf{x}}}{|\mathbf{x}|^2} + \mathcal{O}\left(\frac{|\mathbf{J}|_\infty d^5}{|\mathbf{x}|^3}\right) \right] \quad (3.49)$$

Thus the leading order behaviour of \mathbf{A} far from the source is determined by the magnetic dipole moment.

As an example, let's calculate \mathbf{m} for a thin wire carrying current I around a simple closed curve C . Substituting (3.19) into (3.48) gives

$$\mathbf{m} = \frac{I}{2} \int_C \mathbf{x} \times d\mathbf{x} \quad (3.50)$$

We can evaluate this as follows. Let \mathbf{a} be a constant vector. Then

$$\mathbf{a} \cdot \mathbf{m} = \frac{I}{2} \int_C \mathbf{a} \cdot (\mathbf{x} \times d\mathbf{x}) = \frac{I}{2} \int_C d\mathbf{x} \cdot (\mathbf{a} \times \mathbf{x}) = \frac{I}{2} \int_S [\nabla \times (\mathbf{a} \times \mathbf{x})] \cdot d\mathbf{S} = I\mathbf{a} \cdot \int_S d\mathbf{S} \quad (3.51)$$

where the second inequality uses cyclic symmetry of the scalar triple product, the third equality is Stokes' theorem where S is a surface with boundary C . Since \mathbf{a} is arbitrary we have shown

$$\mathbf{m} = I\mathbf{S} \quad (3.52)$$

where $\mathbf{S} = \int_S d\mathbf{S}$ is the *vector area* of S . In particular, if C lies in a plane then $\mathbf{S} = \mathbf{n}A$ where A is the area enclosed by C and \mathbf{n} the unit normal to the plane (oriented in a right handed sense w.r.t. C). So, in the planar case, \mathbf{m} has magnitude IA and direction \mathbf{n} normal to the plane.

The first term of (3.49) gives the vector potential of an idealized point-like magnetic dipole at the origin:

$$\mathbf{A}_{\text{dipole}}(\mathbf{x}) = \frac{\mu_0 \mathbf{m} \times \hat{\mathbf{x}}}{4\pi |\mathbf{x}|^2} \quad (3.53)$$

Taking the curl gives the corresponding magnetic field:

$$\mathbf{B}_{\text{dipole}}(\mathbf{x}) = \frac{\mu_0 [3(\hat{\mathbf{x}} \cdot \mathbf{m})\hat{\mathbf{x}} - \mathbf{m}]}{4\pi |\mathbf{x}|^3} \quad (3.54)$$

Note the exact correspondence with the electric field of an electric dipole, (2.76). Thus the magnetic field lines produced by a magnetic dipole are identical to the electric field lines of an electric dipole, i.e., Fig. 6 with \mathbf{p} replaced by \mathbf{m} .

The current distribution describing a point-like magnetic dipole at the origin is

$$\mathbf{J}_{\text{dipole}}(\mathbf{x}) = \nabla \times [\mathbf{m} \delta^{(3)}(\mathbf{x})] \quad (3.55)$$

Clearly this satisfies (3.1). This result can be derived by taking a limit of (3.19) in which C is shrunk to a point whilst keeping $\mathbf{m} = I\mathbf{S}$ constant. You can check that substituting $\mathbf{J}_{\text{dipole}}$ into (3.15) reproduces (3.53).

The Earth has a magnetic field produced by electric currents in its (molten iron) core. Equation (3.54) is a reasonable approximation to the magnetic field of the Earth. The Earth's magnetic dipole moment has magnitude $|\mathbf{m}| \approx 8 \times 10^{22} \text{ A m}^2$ and points about 11° away from the Earth's South pole. There is good geological evidence that the direction of \mathbf{m} reverses every 10^5 years or so.

The magnetic dipole moment of a body determines how it responds to an external magnetic field. We can analyze this in the same way as we did for an external electric field in section 2.6. The superposition principle let's us write $\mathbf{B} = \mathbf{B}_{\text{self}} + \mathbf{B}_{\text{ext}}$ where \mathbf{B}_{self} is the field produced by the body and \mathbf{B}_{ext} is the external field. As we discussed above, the self-force on a current distribution vanishes, and the same is true for the self-torque. So we'll only consider the effect of \mathbf{B}_{ext} . Henceforth we'll drop "ext" and just call the external field \mathbf{B} . Consider first the torque on the body. From (1.17) we have

$$\boldsymbol{\tau} = \int_V \mathbf{x} \times (\mathbf{J}(\mathbf{x}) \times \mathbf{B}(\mathbf{x})) d^3\mathbf{x} = \int_V (\mathbf{x} \cdot \mathbf{B}(\mathbf{x})\mathbf{J}(\mathbf{x}) - \mathbf{x} \cdot \mathbf{J}(\mathbf{x})\mathbf{B}(\mathbf{x})) d^3\mathbf{x} \quad (3.56)$$

As in section 2.6 we assume our body is restricted to a region V containing the origin. We assume that V is small compared to the scale over which \mathbf{B} varies so we can approximate \mathbf{B} by its Taylor expansion about the origin:

$$B_i(\mathbf{x}) = B_i(0) + x_j \partial_j B_i(0) + \dots \quad (3.57)$$

Substituting into $\boldsymbol{\tau}$ and keeping just the first term gives

$$\tau_i \approx B_j(0) \int_V d^3\mathbf{x} x_j J_i(\mathbf{x}) - B_i(0) \int_V d^3\mathbf{x} x_j J_j(\mathbf{x}) \quad (3.58)$$

We can now use (3.47): the second term vanishes and the first term gives

$$\boldsymbol{\tau} \approx \mathbf{m} \times \mathbf{B}(0) \quad (3.59)$$

As in the electric case, the torque vanishes if, and only if, \mathbf{m} is aligned or anti-aligned with \mathbf{B} , where the aligned case corresponds to stable equilibrium and the anti-aligned case to unstable equilibrium.

Next we consider the force. Substituting (3.57) into (1.16) gives

$$\begin{aligned}
 F_i &= \int_V d^3\mathbf{x} \epsilon_{ijk} J_j(\mathbf{x}) B_k(\mathbf{x}) = \int_V d^3\mathbf{x} \epsilon_{ijk} J_j(\mathbf{x}) (B_k(0) + x_l \partial_l B_k(0) + \dots) \\
 &\approx \epsilon_{ijk} \partial_l B_k(0) \int_V d^3\mathbf{x} x_l J_j(\mathbf{x}) = \epsilon_{ijk} \partial_l B_k(0) (-\epsilon_{jlp} m_p) = m_k \partial_i B_k(0) - m_i \partial_k B_k(0) \\
 &= m_k \partial_i B_k(0) = \partial_i (m_k B_k)(0)
 \end{aligned} \tag{3.60}$$

where the third equality uses (3.45), the fourth equality uses (3.47) and the fifth equality uses $\nabla \cdot \mathbf{B} = 0$. We have shown that, to leading order, the force exerted on a magnetic dipole by an external magnetic field is

$$\mathbf{F} \approx \nabla(\mathbf{m} \cdot \mathbf{B}) \tag{3.61}$$

This suggests that the potential energy of a magnetic dipole at position \mathbf{x} in a magnetic field is

$$V_{\text{dipole}}(\mathbf{x}) = -\mathbf{m} \cdot \mathbf{B}(\mathbf{x}) \tag{3.62}$$

However, there are subtleties in defining magnetic energy so we'll defer discussion of this to the next section.

Our approach to magnetostatics was to view magnetic fields as generated by currents, and to determine the effect of external fields on currents. But magnetism was not discovered via experiments involving currents. It was discovered (in antiquity) through the fact that some materials in nature, notably iron, exhibit a macroscopic magnetic dipole moment and hence give rise to a magnetic field. Such materials are called *ferromagnetic*. These materials are used to build compass needles, bar magnets etc. These objects respond to external magnetic fields produced by other such objects (or the magnetic field of the Earth) according to the above formulae.

What is the origin of the magnetic dipole moment of ferromagnetic materials? To sketch an answer to this question, let's start by considering a system of moving charged particles. The current is given by (1.12)

$$\mathbf{J}(t, \mathbf{x}) = \sum_{i=1}^N q_i \dot{\mathbf{x}}_i(t) \delta^{(3)}(\mathbf{x} - \mathbf{x}_i(t)) \tag{3.63}$$

Note that this is time-dependent so we are going beyond magnetostatics here. But let's define the magnetic moment exactly as above, allowing for time-dependence:

$$\begin{aligned}\mathbf{m}(t) &= \frac{1}{2} \int d^3\mathbf{x} \mathbf{x} \times \mathbf{J}(t, \mathbf{x}) = \frac{1}{2} \sum_{i=1}^N q_i \int d^3\mathbf{x} \mathbf{x} \times \dot{\mathbf{x}}_i(t) \delta^{(3)}(\mathbf{x} - \mathbf{x}_i(t)) \\ &= \frac{1}{2} \sum_{i=1}^N q_i \mathbf{x}_i(t) \times \dot{\mathbf{x}}_i(t) = \sum_{i=1}^N \frac{q_i}{2m_i} \mathbf{L}_i(t)\end{aligned}\quad (3.64)$$

where $\mathbf{L}_i(t)$ is the angular momentum of the i th particle. If the particles all have the same charge to mass ratio q/m then the magnetic moment is proportional to the total angular momentum \mathbf{L} of the system:

$$\mathbf{m} = \frac{q}{2m} \mathbf{L} \quad (3.65)$$

This reveals a connection between magnetic dipole moments and orbital angular momentum. Orbital angular momentum is not the only kind of angular momentum that particles can possess: they may also possess intrinsic *spin* angular momentum \mathbf{S} (you will learn about this in Principles of Quantum Mechanics). This also contributes to the magnetic moment: a particle with $\mathbf{L} = 0$ has

$$\mathbf{m} = g \frac{q}{2m} \mathbf{S} \quad (3.66)$$

where g is a dimensionless constant of order 1. For the electron $g \approx 2.002$ and \mathbf{m} is anti-aligned with \mathbf{S} (since $q = -e$).

In a material, both the electrons and the atomic nuclei contribute to the total magnetic dipole moment, via orbital and spin angular momentum. Since the electrons have much larger q/m than the nuclei, the contribution from the electrons is much more important than that of the nuclei. Usually the various contributions to the magnetic moment tend to cancel each other out, which is why most materials do not have a macroscopic magnetic dipole moment. However, in a ferromagnetic material, quantum effects lead to an interaction between certain pairs of electrons in neighbouring atoms which makes it favourable for the spins (and hence the magnetic dipole moments) of these electrons to become aligned. This alignment extends over a macroscopically large region (called a magnetic domain), and causes the material to develop a macroscopic magnetic dipole moment.

4 Time-dependence

4.1 Faraday's law of induction

Equation (M3) is

$$\nabla \times \mathbf{E} = -\frac{\partial \mathbf{B}}{\partial t} \quad (4.1)$$

This equation implies that a time-varying magnetic field must be accompanied by an electric field. If a conductor is present then this electric field will cause a current to flow. Thus a time-varying magnetic field²⁶ can produce a current in a conductor. This effect is called *induction*.

To convert (M3) to integral form we integrate over a surface S whose boundary is a simple closed curve C and use Stokes' theorem to obtain

$$\int_C \mathbf{E} \cdot d\mathbf{x} = - \int_S \frac{\partial \mathbf{B}}{\partial t} \cdot d\mathbf{S} \quad (4.2)$$

Assume that S does not depend on time. We can then take the time derivative outside the integral on the RHS to obtain *Faraday's law of induction*

$$\mathcal{E} = -\frac{d\mathcal{F}}{dt} \quad (4.3)$$

where we have defined the *electromotive force* (emf) around C

$$\mathcal{E}(t) = \int_C \mathbf{E}(t, \mathbf{x}) \cdot d\mathbf{x} \quad (4.4)$$

and the *magnetic flux* through S

$$\mathcal{F}(t) = \int_S \mathbf{B}(t, \mathbf{x}) \cdot d\mathbf{S} \quad (4.5)$$

Despite its name, emf is not a force! Consider the case for which there is a thin conducting wire along C . Let $\mathbf{F}(t, \mathbf{x})$ be the Lorentz force acting on a charged particle at position $\mathbf{x} \in C$. We have

$$\frac{1}{q} \int_C \mathbf{F}(t, \mathbf{x}) \cdot d\mathbf{x} = \int_C (\mathbf{E} + \dot{\mathbf{x}} \times \mathbf{B}) \cdot d\mathbf{x} = \mathcal{E} \quad (4.6)$$

where we used the fact that the velocity of each particle must be tangent to the wire so $\dot{\mathbf{x}} \times \mathbf{B}$ is normal to C . When \mathbf{E} is independent of time, the LHS is the work done per unit charge by the Lorentz force when a charged particle moves around C . This

²⁶More precisely: a time-varying magnetic flux - see below.

gives some idea of what \mathcal{E} describes but of course we're mainly interested in situations for which \mathbf{E} *does* depend on time.

Consider the case in which C lies inside a (thick) conducting wire. Let R be the resistance of the wire. Let's repeat the argument that we used to derive Ohm's law in the form $V = IR$ (equation (2.13))

$$\mathcal{E} = \int_C \mathbf{E} \cdot d\mathbf{x} = \int_C \frac{\mathbf{J}}{\sigma} \cdot d\mathbf{x} \approx \frac{|\mathbf{J}|\ell}{\sigma} \quad (4.7)$$

where ℓ is the length of the wire. The current in the wire is $I \approx |\mathbf{J}|A$ where A is the cross-sectional area. Hence

$$\mathcal{E} = IR \quad R = \frac{\ell}{\sigma A} \quad (4.8)$$

Faraday's law now implies that if the magnetic flux through a surface spanning the wire varies with time then a current will be induced in the wire:

$$IR = -\frac{d\mathcal{F}}{dt} \quad (4.9)$$

Example 1. Consider a thin wire formed into a loop C . If a magnet is in motion near to C then the magnetic flux through the loop will be time-dependent, and this will induce a current in the loop.

Example 2. Consider a wire in the form of a closed loop that is placed near to second wire. Now connect the second wire to a battery so that current flows along it. Initially, the current in the second wire will be time-dependent, increasing from zero and then settling down to a steady state. During this time-dependent phase, the magnetic field produced by this current will also be time-dependent. Hence the magnetic flux through the first wire will be time-dependent, so a current will be induced in the first wire. This current is a transient effect - it decays to zero when the current in the second wire becomes time-independent.

Example 3. Take C to be a loop in the xy -plane, which is traversed in the positive (anti-clockwise) sense. Then the normal to S points along the positive z -axis (right-hand rule). Faraday's law (4.3) shows that increasing \mathcal{F} gives negative \mathcal{E} and hence negative I , which implies that the current flows clockwise around C . This current will produce its own magnetic field. To a first approximation we can understand this field by treating the current as time-independent and viewing a small section of C as a straight line. The result (3.8) was that the current I produces a magnetic field with field lines that are circles centred on C with direction determined by the right-hand rule (take thumb in the direction of the current). In our case this implies that, on the xy plane inside C , these field lines point in the negative z -direction. Thus they will contribute

negatively to \mathcal{F} , i.e., tend to reduce \mathcal{F} . On the other hand, if \mathcal{F} were decreasing then the induced current would have the opposite sign and produce a magnetic field that would tend to increase \mathcal{F} . This effect, that the induced current produces a magnetic field that tends to oppose the change in \mathcal{F} is called *Lenz's law*. It arises from the minus sign in (4.3).

In the above discussion we considered a situation in which the surface S does not move. However, Faraday's law can also be applied to situations in which S does move. To see this, let $C(t)$ be a closed curve spanned by an open surface $S(t)$. Consider the magnetic flux through $S(t)$ defined as in (4.5). We then have

$$\begin{aligned}\mathcal{F}(t + \delta t) - \mathcal{F}(t) &= \int_{S(t+\delta t)} \mathbf{B}(t + \delta t, \mathbf{x}) \cdot d\mathbf{S} - \int_{S(t)} \mathbf{B}(t, \mathbf{x}) \cdot d\mathbf{S} \\ &= \int_{S(t+\delta t)} \left[\mathbf{B}(t, \mathbf{x}) + \delta t \frac{\partial \mathbf{B}}{\partial t}(t, \mathbf{x}) + \mathcal{O}(\delta t^2) \right] \cdot d\mathbf{S} - \int_{S(t)} \mathbf{B}(t, \mathbf{x}) \cdot d\mathbf{S} \\ &= \int_{S(t+\delta t) - S(t)} \mathbf{B}(t, \mathbf{x}) \cdot d\mathbf{S} + \delta t \int_{S(t)} \frac{\partial \mathbf{B}}{\partial t}(t, \mathbf{x}) \cdot d\mathbf{S} + \mathcal{O}(\delta t^2)\end{aligned}\quad (4.10)$$

In the final line we replaced $S(t + \delta t)$ by $S(t)$ in the second integral which is legitimate because this integral is multiplied by δt and we are neglecting terms that are $\mathcal{O}(\delta t^2)$.

To evaluate the first term we let δV be the volume swept out by $S(t)$ as we increase t by δt . From (M2) and the divergence theorem we have

$$0 = \int_{\delta V} \nabla \cdot \mathbf{B}(t, \mathbf{x}) dV = \int_{S(t+\delta t) - S(t)} \mathbf{B}(t, \mathbf{x}) \cdot d\mathbf{S} + \int_{\Sigma} \mathbf{B}(t, \mathbf{x}) \cdot d\mathbf{S}\quad (4.11)$$

where Σ is the surface swept out by $C(t)$ as we increase t by δt . The minus sign in the first integral on the RHS arises because we've defined the orientation of $C(t)$ so that the normal of $S(t)$ points *into* δV .

We can write a point on $C(t)$ as $\mathbf{x} = \mathbf{x}(\lambda, t)$ where λ is a parameter around the curve. The infinitesimal tangent to the curve and the velocity of a point on the curve are then

$$d\mathbf{x} = \frac{\partial \mathbf{x}}{\partial \lambda} d\lambda \quad \mathbf{v} = \frac{\partial \mathbf{x}}{\partial t}\quad (4.12)$$

The integral over Σ can be calculated by considering the vector area swept out by an infinitesimal section of $C(t)$. This has tangent $d\mathbf{x}$ and velocity \mathbf{v} so in time δt it sweeps out a vector area $d\mathbf{S} = d\mathbf{x} \times (\mathbf{v}\delta t)$ (note this correctly points *out* of δV). Hence the integral over Σ is

$$\int_{\Sigma} \mathbf{B}(t, \mathbf{x}) \cdot d\mathbf{S} = \int_{C(t)} \mathbf{B}(t, \mathbf{x}) \cdot (d\mathbf{x} \times \mathbf{v})\delta t = \delta t \int_{C(t)} d\mathbf{x} \cdot (\mathbf{v} \times \mathbf{B}(t, \mathbf{x}))\quad (4.13)$$

Combining (4.10), (4.11) and (4.13) we have

$$\mathcal{F}(t + \delta t) - \mathcal{F}(t) = -\delta t \int_{C(t)} d\mathbf{x} \cdot (\mathbf{v} \times \mathbf{B}(t, \mathbf{x})) + \delta t \int_{S(t)} \frac{\partial \mathbf{B}}{\partial t}(t, \mathbf{x}) \cdot d\mathbf{S} + \mathcal{O}(\delta t^2) \quad (4.14)$$

Dividing by δt and letting $\delta t \rightarrow 0$ gives

$$\begin{aligned} \frac{d\mathcal{F}}{dt} &= - \int_{C(t)} d\mathbf{x} \cdot (\mathbf{v} \times \mathbf{B}(t, \mathbf{x})) + \int_{S(t)} \frac{\partial \mathbf{B}}{\partial t}(t, \mathbf{x}) \cdot d\mathbf{S} \\ &= - \int_{C(t)} d\mathbf{x} \cdot (\mathbf{v} \times \mathbf{B}(t, \mathbf{x})) - \int_{S(t)} (\nabla \times \mathbf{E}(t, \mathbf{x})) \cdot d\mathbf{S} \\ &= - \int_{C(t)} (\mathbf{E}(t, \mathbf{x}) + \mathbf{v} \times \mathbf{B}(t, \mathbf{x})) \cdot d\mathbf{x} \end{aligned} \quad (4.15)$$

where we used (M3) in the second equality and Stokes' theorem in the third.

Hence we have

$$\mathcal{E} = - \frac{d\mathcal{F}}{dt} \quad (4.16)$$

where, for a time-dependent curve $C(t)$, we define the emf as

$$\mathcal{E}(t) = \int_{C(t)} (\mathbf{E}(t, \mathbf{x}) + \mathbf{v}(t, \mathbf{x}) \times \mathbf{B}(t, \mathbf{x})) \cdot d\mathbf{x} \quad (4.17)$$

with \mathbf{v} the velocity of the curve. Thus the integral form of Faraday's law takes exactly the same form for a moving curve as for a stationary curve provided we define the emf appropriately.

The emf still satisfies equation (4.6). To see this, consider a thin wire around $C(t)$. A charged particle moving around the wire has $\mathbf{x}(t) = \mathbf{x}(\lambda(t), t)$ hence it has velocity $\dot{\mathbf{x}} = \mathbf{v}_r + \mathbf{v}$ where $\mathbf{v}_r = (\partial \mathbf{x} / \partial \lambda) \dot{\lambda}$ is the velocity of the particle relative to the wire. Since \mathbf{v}_r is parallel to $d\mathbf{x}$, the $\mathbf{v}_r \times \mathbf{B}$ term drops out of the integral as before, but the $\mathbf{v} \times \mathbf{B}$ term arising from the motion of the wire gives a non-vanishing contribution.

If $C(t)$ lies within a conductor then we can use Ohm's law for a moving conductor (1.35) to write

$$\mathcal{E}(t) = \int_{C(t)} \sigma^{-1} \mathbf{J}(t, \mathbf{x}) \cdot d\mathbf{x} \quad (4.18)$$

Hence the emf induced by the motion of the conductor in the magnetic field will cause a current to flow. If a thin wire lies along $C(t)$ then $\mathcal{E}(t)$ is proportional to the current $I(t)$ in the wire and so Ohm's law in the form (4.8) still holds.

Example. Consider a thin wire with resistance R formed into a planar simple closed curve. Assume that the wire is initially in the xy -plane and that there is a constant magnetic field $(0, 0, B)$ in the z -direction. Now let's rotate the wire (by hand) about

the x -axis. Let S be the planar region enclosed by the wire, with the normal chosen initially as $\mathbf{n} = \mathbf{e}_z$. During the rotation we can write $\mathbf{n} = (0, -\sin\theta, \cos\theta)$ where θ is the angle through which the wire has been rotated. By Faraday's law (4.16), the induced emf around the wire is

$$\mathcal{E} = -\frac{d\mathcal{F}}{dt} = -\frac{d}{dt} \int_S \mathbf{B} \cdot \mathbf{n} dA = - \int_S \mathbf{B} \cdot \frac{d\mathbf{n}}{dt} dA = AB \sin\theta \frac{d\theta}{dt} \quad (4.19)$$

where A is the area of S . From Ohm's law, the current in the wire is

$$I = \frac{\mathcal{E}}{R} = \frac{AB}{R} \sin\theta \frac{d\theta}{dt} \quad (4.20)$$

Note that the current changes sign as we rotate the wire. In particular if we rotate the wire with a constant angular velocity ω , i.e., $\theta = \omega t$, we have

$$I = \frac{A\omega B}{R} \sin(\omega t) \quad (4.21)$$

This is an example of an *alternating current*. Returning to the general case, let $Q(t)$ be the total charge that has flowed past a particular point of the circuit. From the definition of current we have $I = dQ/dt$. Hence we can integrate (4.20) to obtain the total charge that flows around the loop when we rotate it through π :

$$Q = \frac{AB}{R} [-\cos\theta]_0^\pi = \frac{2AB}{R} \quad (4.22)$$

Note that this is independent of *how* we rotate, whether at constant angular velocity or otherwise.

4.2 Energy of the electromagnetic field

In electrostatics we saw that instead of talking about particles possessing potential energy, we could instead view this as energy carried by the electric field. Specifically, the energy carried by the electric field in a region V is

$$E = \int_V \frac{\epsilon_0}{2} \mathbf{E}^2 dV \quad (4.23)$$

We now want to go beyond electrostatics and determine the energy carried by a general electromagnetic field. Before we do this, let's think about what we mean by energy. Consider a ball. If the ball rolls along a frictionless horizontal plane then it has a conserved quantity that we call kinetic energy. However, if the plane is inclined then kinetic energy is no longer conserved so we introduce a new quantity called potential energy such that the sum of kinetic and potential energy is conserved. If the plane is

not frictionless then we say that friction leads to heating and we can introduce a notion of heat energy such that the sum of kinetic, potential and heat energy is conserved. So at each stage, we are generalizing our notion of energy, adding some new effect, such that the result is conserved. Since what we started from was called energy, we view each new effect as some new form of energy.²⁷

Let's play this game for electromagnetism, starting from the above expression for the energy of an electric field in electrostatics. We will assume that this expression gives the energy of an electric field even in a time-dependent situation, and see what we have to add in order to obtain a conserved quantity. To calculate the time-derivative of E we use

$$\begin{aligned} \frac{\partial}{\partial t} \left(\frac{\epsilon_0}{2} \mathbf{E}^2 \right) &= \epsilon_0 \mathbf{E} \cdot \frac{\partial \mathbf{E}}{\partial t} = \epsilon_0 c^2 \mathbf{E} \cdot (\nabla \times \mathbf{B} - \mu_0 \mathbf{J}) \\ &= \frac{1}{\mu_0} [\mathbf{B} \cdot \nabla \times \mathbf{E} - \nabla \cdot (\mathbf{E} \times \mathbf{B})] - \mathbf{E} \cdot \mathbf{J} \\ &= \frac{1}{\mu_0} \left[-\mathbf{B} \cdot \frac{\partial \mathbf{B}}{\partial t} - \nabla \cdot (\mathbf{E} \times \mathbf{B}) \right] - \mathbf{E} \cdot \mathbf{J} \end{aligned} \quad (4.24)$$

The second equality uses (M4), the third equality uses $c^2 = 1/(\epsilon_0 \mu_0)$ and a vector calculus identity; the final equality uses (M3). We can rearrange the above equation to read

$$\frac{\partial w}{\partial t} + \nabla \cdot \mathbf{S} + \mathbf{E} \cdot \mathbf{J} = 0 \quad (4.25)$$

where

$$w = \frac{\epsilon_0}{2} \mathbf{E}^2 + \frac{1}{2\mu_0} \mathbf{B}^2 \quad (4.26)$$

and we define the *Poynting vector*

$$\mathbf{S} = \frac{\mathbf{E} \times \mathbf{B}}{\mu_0} \quad (4.27)$$

Now integrate (4.25) over a (time-independent) volume V with boundary S and use the divergence theorem to obtain

$$\frac{d}{dt} \int_V w dV = - \int_S \mathbf{S} \cdot \mathbf{n} dA - \int_V \mathbf{E} \cdot \mathbf{J} dV \quad (4.28)$$

where \mathbf{n} is the outward normal to S . We will now see that this is an energy conservation equation. First note that w generalizes the energy density we used in electrostatics, by adding an extra term $\mathbf{B}^2/(2\mu_0)$ which we interpret as the energy density of the

²⁷The fact that this is possible is a consequence of Noether's theorem, which relates conservation laws to symmetries of the laws of physics. In this case, the symmetry is invariance under time translations.

magnetic field. So we interpret w as the energy density of the electromagnetic field. The LHS is the rate of increase of the energy of the electromagnetic field in V . Now energy may leave V by crossing S e.g. in the form of electromagnetic waves. The first term on the RHS describes a flux across S . So we interpret $\mathbf{S} \cdot \mathbf{n}$ as the *energy flux* across S , i.e., the energy per unit time per unit area crossing S . Thus the Poynting vector determines this energy flux. Its direction gives an indication of the direction in which electromagnetic energy is flowing. The second term on the RHS arises because the electromagnetic field may lose energy by doing work on charged matter. The rate of doing work is precisely the final term above. To see this, view the charged matter inside V as made from N charged particles. The rate of working of the electromagnetic field on the i th particle is, from the Lorentz force law,

$$\mathbf{F} \cdot \dot{\mathbf{x}}_i = q_i (\mathbf{E}(t, \mathbf{x}_i) + \dot{\mathbf{x}}_i(t) \times \mathbf{B}(t, \mathbf{x}_i)) \cdot \dot{\mathbf{x}}_i(t) = q_i \mathbf{E}(t, \mathbf{x}_i) \cdot \dot{\mathbf{x}}_i(t) \quad (4.29)$$

Summing over N particles gives the total rate of working

$$\sum_{i=1}^N q_i \mathbf{E}(t, \mathbf{x}_i) \cdot \dot{\mathbf{x}}_i = \sum_{i=1}^N \int_V q_i \mathbf{E}(t, \mathbf{x}) \cdot \dot{\mathbf{x}}_i(t) \delta^{(3)}(\mathbf{x} - \mathbf{x}_i(t)) dV = \int_V \mathbf{E} \cdot \mathbf{J} dV \quad (4.30)$$

where \mathbf{J} is the current density corresponding to the N particles, as given by (1.12). Since we can view any current density as arising from a set of particles, this establishes that the second term on the RHS of (4.28) is minus the rate of working of the electromagnetic field on the charged matter. Thus equation (4.28) states that the rate of increase of the energy in the electromagnetic field is equal to minus the rate that energy leaves V across S minus the rate at which the electromagnetic field does work on charged matter inside V .

The notion of “work done” is just a book-keeping device that lets us keep track of energy transfer between different parts of a physical system, in this case the electromagnetic field and the charged matter. If we consider the *total* energy of the electromagnetic field and the charged matter then the work term cancels out: it decreases the energy of the field but increases the energy of the matter. This total energy can only change if energy (or matter) crosses S .

If \mathbf{J} arises from a current in a conductor then we can use Ohm’s law to write the rate of working of the electromagnetic field inside the conductor as

$$\int_V \mathbf{E} \cdot \mathbf{J} dV = \int_V \frac{1}{\sigma} \mathbf{J}^2 dV \quad (4.31)$$

Where does this energy go? The electric field increases the kinetic energy of the free charges inside the conductor. These charges collide with the ions of the metal lattice,

transferring energy to them and causing them to vibrate faster. This faster vibration means that the temperature of the metal has increased. So the work done by the electromagnetic field is converted into heat energy in the conductor. This process is called *Joule heating*.

In the case of a thin wire at rest inside V we can use (3.19) to write the rate of working of the electromagnetic field as

$$\int_V \mathbf{E} \cdot \mathbf{J} dV = I \int_C \mathbf{E} \cdot d\mathbf{x} = I\mathcal{E} \quad (4.32)$$

The same calculation reveals that the electromagnetic field does work at a rate IV when a potential difference V causes a current I to flow in a section of wire. In either case we can use the thin-wire version of Ohm's law to write this as I^2R , so this is the rate of Joule heating in the wire.

As a special case of the above discussion, we've now determined the formula for the energy density of a magnetic field. In the rest of this section we'll apply this to magnetostatics. The total energy in the magnetic field in all of \mathbb{R}^3 is

$$\begin{aligned} E_B &= \frac{1}{2\mu_0} \int d^3\mathbf{x} \mathbf{B}^2 = \frac{1}{2\mu_0} \int d^3\mathbf{x} \mathbf{B} \cdot \nabla \times \mathbf{A} = \frac{1}{2\mu_0} \int d^3\mathbf{x} [\mathbf{A} \cdot \nabla \times \mathbf{B} - \nabla \cdot (\mathbf{B} \times \mathbf{A})] \\ &= \frac{1}{2} \int d^3\mathbf{x} \mathbf{J}(\mathbf{x}) \cdot \mathbf{A}(\mathbf{x}) \end{aligned} \quad (4.33)$$

where the first equality is the definition of the vector potential, the second equality is a vector calculus identity (the same as above) and the third equality uses Ampère's law and the divergence theorem, and assumes that $\mathbf{B} \times \mathbf{A}$ decays at infinity fast enough for the surface term to vanish. The final expression is the magnetostatics analogue of the RHS of equation (2.28) in electrostatics. If one substitutes in the solution for \mathbf{A} given by (3.15) then one obtains

$$E_B = \frac{\mu_0}{8\pi} \int d^3\mathbf{x} d^3\mathbf{x}' \frac{\mathbf{J}(\mathbf{x}) \cdot \mathbf{J}(\mathbf{x}')}{|\mathbf{x} - \mathbf{x}'|} \quad (4.34)$$

Just like (2.28), E_B can be regarded as the energy required to create the current distribution \mathbf{J} that gives rise to \mathbf{B} .

Consider a thick wire carrying current density \mathbf{J} and total current I . Since I is proportional to \mathbf{J} we can write

$$E_B = \frac{1}{2} LI^2 \quad (4.35)$$

where L is called the *self-inductance* of the wire. It depends only on the geometry of the wire and the way the current density varies across a cross-section of the wire, but

not on the value of I . The self-inductance cannot be calculated using the thin-wire approximation because the above integral diverges in this limit.

Example. Consider a wire formed into a long, but finite, solenoid of length ℓ and cross-sectional area A . We assume that our solution (3.42) for the magnetic field of an infinite solenoid is a good approximation, so $\mathbf{B}^2 \approx \mu_0^2 N^2 I^2$ inside the solenoid and $\mathbf{B} \approx 0$ outside the solenoid where N is the number of turns of wire per unit length. Thus the total magnetic energy is

$$E_B \approx \frac{\mu_0^2 N^2 I^2 \ell A}{2\mu_0} = \frac{\mu_0 n^2 I^2 A}{2\ell} \quad (4.36)$$

where $n = N\ell$ is the total number of turns of the wire. Hence we can read off the self-inductance as

$$L \approx \frac{\mu_0 n^2 A}{\ell} \quad (4.37)$$

Example. Consider a circuit consisting of a capacitor with capacitance C connected by wires of resistance R to a solenoid of self-inductance L . Assume that the total electric field energy is given by the electrostatic formula $(1/2)CQ^2$ (where $\pm Q$ is the charge on the plates of the capacitor) and the total magnetic field energy is given by the magnetostatic formula $(1/2)LI^2$. Then using (4.32), our energy conservation equation (4.28) is

$$\frac{d}{dt} \left(\frac{1}{2}CQ^2 + \frac{1}{2}LI^2 \right) = -I\mathcal{E} \quad (4.38)$$

Here we are assuming that there is negligible energy radiated by the circuit in the form of electromagnetic waves,²⁸ so the energy flux term through a surface surrounding the circuit is zero. We now use Ohm's law to write the RHS as $-I^2R$. Finally we have $I = -\dot{Q}$ and so the above equation reduces to

$$L\ddot{Q} + R\dot{Q} + CQ = 0 \quad (4.39)$$

This is the equation of a damped harmonic oscillator. We could include a switch in the circuit which is open for $t < 0$ and closed for $t \geq 0$. We then have $Q = Q(0)$ for $t < 0$ and, for $t > 0$, we have the usual behaviour of the damped harmonic oscillator. In particular, if $R^2 \ll 4LC$ then the system is underdamped and will oscillate for a long time at the resonant frequency $(C/L)^{1/2}$, with charge flowing backwards and forwards between the two plates of the capacitor.

Now consider two thick non-intersecting wires carrying current densities \mathbf{J}_1 and \mathbf{J}_2 . We have $\mathbf{J} = \mathbf{J}_1 + \mathbf{J}_2$. We write the corresponding vector potential as $\mathbf{A} = \mathbf{A}_1 + \mathbf{A}_2$. The energy is therefore

$$E_B = E_{11} + E_{12} + E_{21} + E_{22} \quad (4.40)$$

²⁸This is true if the time variation is not too rapid and the circuit is not too big.

where

$$E_{ij} = \frac{1}{2} \int d^3\mathbf{x} \mathbf{J}_i(\mathbf{x}) \cdot \mathbf{A}_j(\mathbf{x}) = \frac{\mu_0}{8\pi} \int d^3\mathbf{x} d^3\mathbf{x}' \frac{\mathbf{J}_i(\mathbf{x}) \cdot \mathbf{J}_j(\mathbf{x}')}{|\mathbf{x} - \mathbf{x}'|} \quad (4.41)$$

and so $E_{12} = E_{21}$. Let I_1, I_2 be the currents in each wire. We have $E_{11} = (1/2)L_1I_1^2$ where L_1 is the self-inductance of the first wire, and similarly for E_{22} . The “interaction” term $E_{12} = E_{21}$ can be calculated in the thin-wire limit. In this limit we have

$$E_{12} = E_{21} = \frac{1}{2}M_{12}I_1I_2 \quad (4.42)$$

where

$$M_{12} = \frac{\mu_0}{4\pi} \int_{C_1} \int_{C_2} \frac{d\mathbf{x}_1 \cdot d\mathbf{x}_2}{|\mathbf{x}_1 - \mathbf{x}_2|} \quad (4.43)$$

M_{12} is called the *mutual inductance* of the wires. It depends only the geometry of the curves C_i . From the first equality in (4.41) we can write

$$E_{12} = \frac{I_1}{2} \int_{C_1} d\mathbf{x} \cdot \mathbf{A}_2 = \frac{I_1}{2} \int_{S_1} \mathbf{B}_2 \cdot d\mathbf{S} = \frac{1}{2}I_1\Phi_{12} \quad (4.44)$$

where Φ_{12} is the magnetic flux through C_1 due to the second wire. Comparing the above expressions we see that

$$\Phi_{12} = M_{12}I_2 \quad (4.45)$$

Thus the mutual inductance determines the magnetic flux through the first wire produced by the second wire. There is no analogue of this formula for Φ_{11} because the divergence of the magnetic field on a thin wire implies that Φ_{11} is infinite for a thin wire.

4.3 Electromagnetic waves

We saw in section 1.4 that Maxwell’s equation imply that, in vacuum ($\rho = \mathbf{J} = 0$), \mathbf{E} and \mathbf{B} satisfy the wave equation with speed c . Thus we expect Maxwell’s equations to admit solutions describing waves propagating at the speed of light. In this section we will study the simplest such solutions: monochromatic *plane waves*. These are solutions of the form²⁹

$$\mathbf{E} = \text{Re}(\mathbf{E}_0 e^{-i\omega t + i\mathbf{k} \cdot \mathbf{x}}) \quad \mathbf{B} = \text{Re}(\mathbf{B}_0 e^{-i\omega t + i\mathbf{k} \cdot \mathbf{x}}) \quad (4.46)$$

where \mathbf{E}_0 and \mathbf{B}_0 are *complex* constants and ω and \mathbf{k} are real constants. The reason for writing \mathbf{E} and \mathbf{B} as the real part of a complex expression is that it is easier to work

²⁹Monochromatic means that the waves have a definite frequency ω . More general plane wave solutions are obtained starting from the assumption that each component of \mathbf{E} and \mathbf{B} is an arbitrary function of $\omega t - \mathbf{k} \cdot \mathbf{x}$.

with exponentials than with cosines and sines. It also provides a convenient way of allowing the different components of \mathbf{E} and \mathbf{B} to have different phases. Note that the parameters $(\omega, \mathbf{k}, \mathbf{E}_0, \mathbf{B}_0)$ give the same \mathbf{E} and \mathbf{B} as $(-\omega, -\mathbf{k}, \bar{\mathbf{E}}_0, \bar{\mathbf{B}}_0)$. Hence there is no loss of generality in assuming $\omega > 0$.

Let's plug this Ansatz into Maxwell's equations (in vacuum) to see what we get. First (M1) and (M2) reduce to

$$\operatorname{Re}(i\mathbf{E}_0 \cdot \mathbf{k}e^{-i\omega t + i\mathbf{k} \cdot \mathbf{x}}) = 0 \quad \operatorname{Re}(i\mathbf{B}_0 \cdot \mathbf{k}e^{-i\omega t + i\mathbf{k} \cdot \mathbf{x}}) = 0 \quad (4.47)$$

The only way of satisfying these equations for all (t, \mathbf{x}) is if

$$\mathbf{E}_0 \cdot \mathbf{k} = \mathbf{B}_0 \cdot \mathbf{k} = 0 \quad (4.48)$$

Substituting (4.46) into (M3) gives

$$\operatorname{Re}(i\mathbf{k} \times \mathbf{E}_0 e^{-i\omega t + i\mathbf{k} \cdot \mathbf{x}}) = \operatorname{Re}(i\omega \mathbf{B}_0 e^{-i\omega t + i\mathbf{k} \cdot \mathbf{x}}) \quad (4.49)$$

and for this to hold for all (t, \mathbf{x}) we must have

$$\omega \mathbf{B}_0 = \mathbf{k} \times \mathbf{E}_0 \quad (4.50)$$

Finally substituting (4.46) into (M4) gives

$$\operatorname{Re}(i\mathbf{k} \times \mathbf{B}_0 e^{-i\omega t + i\mathbf{k} \cdot \mathbf{x}}) = -\frac{1}{c^2} \operatorname{Re}(i\omega \mathbf{E}_0 e^{-i\omega t + i\mathbf{k} \cdot \mathbf{x}}) \quad (4.51)$$

which implies

$$\omega \mathbf{E}_0 = -c^2 \mathbf{k} \times \mathbf{B}_0 \quad (4.52)$$

We now have

$$\omega^2 \mathbf{E}_0 = -c^2 \mathbf{k} \times (\omega \mathbf{B}_0) = -c^2 \mathbf{k} \times (\mathbf{k} \times \mathbf{E}_0) = -c^2 [(\mathbf{k} \cdot \mathbf{E}_0) \mathbf{k} - \mathbf{k}^2 \mathbf{E}_0] = c^2 \mathbf{k}^2 \mathbf{E}_0 \quad (4.53)$$

where we used (4.48) in the final step. Since $\omega > 0$ it follows that

$$\omega = c|\mathbf{k}| \quad (4.54)$$

A relation between frequency ω and wavevector \mathbf{k} is called a *dispersion relation*. So (4.54) is the dispersion relation for electromagnetic waves.

In summary, (4.46) solves Maxwell equations if (ω, \mathbf{k}) obeys (4.54), we pick \mathbf{E}_0 to obey (4.48) and we use (4.50) to define \mathbf{B}_0 (which then automatically obeys (4.48)).

Let's now discuss the physical interpretation of these solutions. First note, that the expressions (4.46) are constant on the *surfaces of constant phase* $\mathbf{k} \cdot \mathbf{x} = \omega(t - t_0)$

where t_0 is a constant labelling the surfaces. Each surface of constant phase is a plane with normal in the direction \mathbf{k} and is distance $(\omega/|\mathbf{k}|)(t - t_0)$ from the origin. Hence the speed of these surfaces, known as the *phase velocity* of the waves is $|\omega|/|\mathbf{k}| = c$. So (4.46) describes plane waves propagating with speed c in direction \mathbf{k} .

At any fixed point \mathbf{x} the directions of \mathbf{E} and \mathbf{B} oscillates periodically in time. The condition (4.48) implies that

$$\mathbf{E} \cdot \mathbf{k} = \mathbf{B} \cdot \mathbf{k} = 0 \quad (4.55)$$

Hence the directions of the electric and magnetic field oscillations are always perpendicular to the direction of propagation of the wave. Such waves are referred to as *transverse*. This distinguishes them from *longitudinal* waves, such as sound waves, for which the oscillations lie in the direction of \mathbf{k} . Similarly equation (4.50) implies that

$$\omega \mathbf{B} = \mathbf{k} \times \mathbf{E} \quad (4.56)$$

so the electric and magnetic fields of a plane wave are also perpendicular to each other. Hence, at any point, the vectors \mathbf{E} , \mathbf{B} and \mathbf{k} form an orthogonal basis.

The constants \mathbf{E}_0 and \mathbf{B}_0 describe the *polarization* of the wave, i.e., the directions in which the electric and magnetic fields oscillate. To see this in more detail, choose axes such that $\mathbf{k} = (0, 0, k)$ where $k > 0$ so $\omega = ck$. Equations (4.48) and (4.50) now imply

$$\mathbf{E}_0 = (\alpha, \beta, 0) \quad \mathbf{B}_0 = \frac{1}{c}(-\beta, \alpha, 0) \quad (4.57)$$

for complex constants α, β . Clearly we have a two dimensional space of possible polarization vectors. Thus we say that electromagnetic waves have two independent polarizations.

Writing α, β in modulus-argument form we have

$$\alpha = |\alpha|e^{i\delta_1} \quad \beta = |\beta|e^{i\delta_2}. \quad (4.58)$$

Consider a solution with $\beta = 0$

$$\begin{aligned} \mathbf{E} &= \mathbf{e}_x \operatorname{Re} (|\alpha|e^{-i\omega t + i\mathbf{k} \cdot \mathbf{x} + i\delta_1}) = \mathbf{e}_x |\alpha| \cos(\omega t - \mathbf{k} \cdot \mathbf{x} - \delta_1) \\ \mathbf{B} &= \frac{1}{c} \mathbf{e}_y \operatorname{Re} (|\alpha|e^{-i\omega t + i\mathbf{k} \cdot \mathbf{x} + i\delta_1}) = \mathbf{e}_y \frac{|\alpha|}{c} \cos(\omega t - \mathbf{k} \cdot \mathbf{x} - \delta_1) \end{aligned} \quad (4.59)$$

This describes a wave in which the \mathbf{E} field oscillates in the x -direction and the \mathbf{B} field oscillates in the y -direction. Similarly if we set $\alpha = 0$ then we obtain a solution for which the \mathbf{E} field oscillates in the y -direction and the \mathbf{B} field oscillates in the x -direction. These solutions are said to have *linear polarization*. This means that the

\mathbf{E} always points in the same direction (up to signs), with the \mathbf{B} field pointing in an orthogonal direction.

A general linear polarization corresponds to the special case $\delta_1 = \delta_2$. In this case, the \mathbf{E} field oscillates in the xy plane in a direction making an angle $\tan^{-1}(\beta/\alpha)$ to the x -axis, and the \mathbf{B} field oscillates in the xy plane in a direction orthogonal to the direction of \mathbf{E} oscillations.

In the general case $\delta_1 \neq \delta_2$ then the waves are not linearly polarized. Instead they are said to be *elliptically polarized*. To understand this, we first consider another special case: $\beta = \pm i\alpha$. We then have

$$\mathbf{E} = \mathbf{e}_x |\alpha| \cos(\omega t - \mathbf{k} \cdot \mathbf{x} - \delta_1) \pm \mathbf{e}_y |\alpha| \sin(\omega t - \mathbf{k} \cdot \mathbf{x} - \delta_1) \quad (4.60)$$

and similarly for \mathbf{B} . Now we have $E_1^2 + E_2^2 = |\alpha|^2$, i.e., the electric field vector is constant in magnitude and (in contrast with linear polarization) never vanishes. At any fixed point \mathbf{x} , the direction of this vector rotates around a circle in the xy -plane with constant angular velocity ω . Hence this case is referred to as *circular polarization*. The two signs in (4.60) give two independent circular polarizations.

Elliptical polarization is similar except that now the direction of the electric (and magnetic) field traces out an ellipse rather than a circle. Circular polarization is described by two real numbers: the real and imaginary parts of α . Elliptical polarization is described by four real numbers: the real and imaginary parts of α and β . The additional two numbers specify the ratio of the lengths of the axes of the ellipse, and the angle between the major axis of the ellipse and the x -axis at, say, $t = \mathbf{x} = 0$. The \mathbf{B} field also traces out an ellipse, with axes orthogonal to those of the \mathbf{E} field.

Let's now consider the energy associated with a plane wave. The energy density in the electromagnetic field is

$$w = \frac{\epsilon_0}{2} \mathbf{E}^2 + \frac{1}{2\mu_0} \mathbf{B}^2 \quad (4.61)$$

to evaluate this, we substitute (4.46). This gives

$$\begin{aligned} \mathbf{E}^2 &= \left[\frac{1}{2} (\mathbf{E}_0 e^{-i\omega t + i\mathbf{k} \cdot \mathbf{x}} + \bar{\mathbf{E}}_0 e^{i\omega t - i\mathbf{k} \cdot \mathbf{x}}) \right]^2 = \frac{1}{4} (\mathbf{E}_0^2 e^{-2i\omega t + 2i\mathbf{k} \cdot \mathbf{x}} + \bar{\mathbf{E}}_0^2 e^{2i\omega t - 2i\mathbf{k} \cdot \mathbf{x}} + 2|\mathbf{E}_0|^2) \\ &= \frac{1}{2} \text{Re} (\mathbf{E}_0^2 e^{-2i\omega t + 2i\mathbf{k} \cdot \mathbf{x}}) + \frac{1}{2} |\mathbf{E}_0|^2 \end{aligned} \quad (4.62)$$

where $\mathbf{E}_0^2 = \mathbf{E}_0 \cdot \mathbf{E}_0$ is complex and $|\mathbf{E}_0|^2 = \mathbf{E}_0 \cdot \bar{\mathbf{E}}_0$ is real. Similarly

$$\mathbf{B}^2 = \frac{1}{2} \text{Re} (\mathbf{B}_0^2 e^{-2i\omega t + 2i\mathbf{k} \cdot \mathbf{x}}) + \frac{1}{2} |\mathbf{B}_0|^2 \quad (4.63)$$

Choosing axes so that $\mathbf{k} = (0, 0, k)$ we can use (4.57) to obtain

$$\mathbf{B}_0^2 = \frac{1}{c^2} (\alpha^2 + \beta^2) = \epsilon_0 \mu_0 \mathbf{E}_0^2 \quad |\mathbf{B}_0|^2 = \frac{1}{c^2} (|\alpha|^2 + |\beta|^2) = \epsilon_0 \mu_0 |\mathbf{E}_0|^2 \quad (4.64)$$

where we used $1/c^2 = \epsilon_0\mu_0$. Using these results, the energy density is

$$w = \frac{\epsilon_0}{2} \operatorname{Re} (\mathbf{E}_0^2 e^{-2i\omega t + 2i\mathbf{k}\cdot\mathbf{x}}) + \frac{\epsilon_0}{2} |\mathbf{E}_0|^2 \quad (4.65)$$

If we write $\mathbf{E}_0^2 = r e^{i\phi}$ then the first term is proportional to $\cos(2\omega t - 2\mathbf{k}\cdot\mathbf{x} - \phi)$. Hence at any point \mathbf{x} it oscillates periodically in time with frequency 2ω , and the time-average of this term is zero. Thus the time-averaged energy density is

$$\langle w \rangle = \frac{\epsilon_0}{2} |\mathbf{E}_0|^2 \quad (4.66)$$

Now consider the Poynting vector

$$\begin{aligned} \mathbf{S} &= \frac{1}{\mu_0} \mathbf{E} \times \mathbf{B} = \frac{1}{4\mu_0} (\mathbf{E}_0 e^{-i\omega t + i\mathbf{k}\cdot\mathbf{x}} + \bar{\mathbf{E}}_0 e^{i\omega t - i\mathbf{k}\cdot\mathbf{x}}) \times (\mathbf{B}_0 e^{-i\omega t + i\mathbf{k}\cdot\mathbf{x}} + \bar{\mathbf{B}}_0 e^{i\omega t - i\mathbf{k}\cdot\mathbf{x}}) \\ &= \frac{1}{2\mu_0} \operatorname{Re} (\mathbf{E}_0 \times \mathbf{B}_0 e^{-2i\omega t + 2i\mathbf{k}\cdot\mathbf{x}}) + \frac{1}{4\mu_0} (\mathbf{E}_0 \times \bar{\mathbf{B}}_0 + \bar{\mathbf{E}}_0 \times \mathbf{B}_0) \end{aligned} \quad (4.67)$$

As above, the first term gives a contribution that, at any point \mathbf{x} , oscillates in time with frequency 2ω and averages to zero. Hence the time-averaged Poynting vector is

$$\begin{aligned} \langle \mathbf{S} \rangle &= \frac{1}{2\mu_0} \operatorname{Re} (\mathbf{E}_0 \times \bar{\mathbf{B}}_0) = \frac{1}{2\omega\mu_0} \operatorname{Re} [\mathbf{E}_0 \times (\mathbf{k} \times \bar{\mathbf{E}}_0)] \\ &= \frac{1}{2\omega\mu_0} \operatorname{Re} [|\mathbf{E}_0|^2 \mathbf{k} - (\mathbf{E}_0 \cdot \mathbf{k}) \bar{\mathbf{E}}_0] = \frac{|\mathbf{E}_0|^2}{2\omega\mu_0} \mathbf{k} \end{aligned} \quad (4.68)$$

where we used (4.50) in the second equality and (4.48) in the final equality. Finally using $\omega = c|\mathbf{k}|$ and $1/c^2 = \epsilon_0\mu_0$ we obtain

$$\langle \mathbf{S} \rangle = \frac{c\epsilon_0}{2} |\mathbf{E}_0|^2 \hat{\mathbf{k}} = cw \hat{\mathbf{k}} \quad (4.69)$$

where $\hat{\mathbf{k}} = \mathbf{k}/|\mathbf{k}|$. To understand this, consider a plane orthogonal to $\hat{\mathbf{k}}$. The Poynting vector gives the energy per unit area per unit time crossing this surface. In time Δt the above result implies that the average energy crossing a portion of the plane of area A is $cwA\Delta t = w(Ac\Delta t)$. Hence, in time Δt all of the energy in a region of volume $Ac\Delta t$ crosses this portion of the plane, which shows that the electromagnetic plane wave transports energy at the speed of light c .

Finally we note that since Maxwell's equations are linear, any superposition of plane waves will solve these equations. This shows that electromagnetic waves do not interact with each other.