

Part II Dynamical Systems Michaelmas Term 2014

lecturer: Professor Peter Haynes (phh1@cam.ac.uk)

October 9, 2014

These lecture notes, plus examples sheets and any other extra material will be made available at <http://www.damtp.cam.ac.uk/user/phh/dynsys.html>.

Note that in 2014-15 this is being lectured as a D course. There is no change in the syllabus from 2013-14, but the 2015 examination questions will be of D-course type.

Informal Introduction

Course Structure

Informal Introduction

Section 1: Introduction and Basic Definitions [3]

Section 2: Fixed Points of Flows in \mathbb{R}^2 [3]

Section 3: Stability [2]

Section 4: Existence and Stability of Periodic Orbits in \mathbb{R}^2 [5]

Section 5: Bifurcations of Flows [3]

Section 6: Fixed Points and Bifurcations of Maps [2]

Section 7: Chaos [6]

Books

There are many excellent texts. The following are those listed in the *Schedules*.

- P.A. Glendinning *Stability, Instability and Chaos* [CUP].
A very good text written in clear language.
- D.K. Arrowsmith & C.M. Place *Introduction to Dynamical Systems* [CUP].
Also very good and clear, covers a lot of ground.

- P.G. Drazin *Nonlinear Systems* [CUP].
Covers a great deal of ground in some detail. Good on the maps part of the course. Could be the book to go to when others fail to satisfy.
- J. Guckenheimer & P. Holmes *Nonlinear Oscillations, Dynamical Systems and Bifurcations of Vector Fields* [Springer]
Comprehensive treatment of most of the course material and beyond. The style is mathematically more sophisticated than of the lectures.
- D.W. Jordan & P. Smith *Nonlinear Ordinary Differential Equations* [OUP].
A bit long in the tooth and not very rigorous but has some very useful material especially on perturbation theory.

Other books:

- S.H. Strogatz *Nonlinear Dynamics and Chaos* [Perseus Books, Cambridge, MA.]
An excellent informal treatment, emphasising applications. Inspirational!
- R. Grimshaw *An Introduction to Nonlinear Ordinary Differential Equations* [CRC Press].
Very good on stability of periodic solutions. Quite technical in parts.

Motivation

A 'dynamical system' is a system, whose configuration is described by a state space, with a mathematically specified rule for evolution in time. Time may be continuous, in which the rule for evolution might typically be a differential equation, or discrete, in which case the rule takes the form of a map from the state space to itself. The study of dynamical systems originates in Newtonian dynamics, e.g. planetary systems, but is relevant to any system in physics, biology, economics, etc. where the notion of time evolution is relevant.

In this course we shall be concerned with nonlinear dynamical systems, i.e. the rule for time evolution takes the form of a nonlinear equation. Of course the evolution of some simple systems such as a pendulum following simple harmonic motion can be expressed in terms of linear equations: but to know how the period of the pendulum changes with amplitude the linear equations are not adequate - we must solve a nonlinear equation. Solving a linear system usually requires a simple set of mathematical tasks, such as determining eigenvalues. Nonlinear systems have an amazingly rich structure, and most importantly they do not in general have analytical solutions, or at least none expressible in terms of elementary (or even non-elementary) functions. Thus in general we rely on a *geometric* approach, which allows the determination of important characteristics of the solution without the need for explicit solution. (The geometry here is the geometry of solutions in the state space.) Much of the course will be taken up with such ideas.

We also study the *stability* of various simple solutions. A simple special solution (e.g. a steady or periodic state) is not of much use if small perturbations destroy it (e.g. a pencil balanced exactly on its point). So we need to know what happens to solutions that start near such a special solution. This involves linearizing, which allows the classification of fixed and periodic points (the latter corresponding to periodic oscillations). We shall also develop *perturbation methods*, which allow us to find good approximations to solutions that are close to well-understood simple solutions.

Many nonlinear systems depend on one or more *parameters*. Examples include the simple equation $\dot{x} = \mu x - x^3$, where the parameter μ can take positive or negative values. If $\mu > 0$ there are three stationary points, while if $\mu < 0$ there is only one. The point $\mu = 0$ is called a *bifurcation point*, and we shall see that we can classify bifurcations and develop a general method for determining the solutions near such points.

Many of the systems we shall consider correspond to second order differential equations, and we shall see that these have relatively simple long-time solutions (fixed and periodic points, essentially). In the last part of the course we shall look at some aspects of third order (and time-dependent second order) systems, which can exhibit "chaos". These systems are usually treated by the study of maps (of the line or the plane) which can be related to the dynamics of the differential system. Maps can be treated in a rigorous manner and there are some remarkable theorems (such as Sharkovsky's on the order of appearance of periodic orbits in one-humped maps of the interval) that can be proved.

A simple example of a continuous-time dynamical system is the *Lotka-Volterra system* describing two competing populations (e.g. r =rabbits, s =sheep):

$$\dot{r} = r(a - br - cs), \quad \dot{s} = s(d - cr - fs)$$

where a, b, c, d, e, f are (positive in this example) constants. This is a *second order system* which is *autonomous* (time does not appear explicitly). The system lives in the *state*

note that
is not all
of \mathbb{R}^2

space or phase space $(r, s) \in [0, \infty) \times [0, \infty)$. We regard r, s as continuous functions of time and the dynamical system is said to describe a *flow* in the state space, which takes a point describing the configuration at one time to that describing it at a later time. The solutions follow curves in the phase space called *trajectories*.

Typical analysis looks at *fixed points*. These are at $(r, s) = (0, 0)$, $(r, s) = (0, d/f)$, $(r, s) = (a/b, 0)$ and a solution with $r, s \neq 0$ as long as $bf \neq ce$. Assuming, as can be proved, that at long times the solution tends to one of these, we can look at local approximations near the fixed points. Near $(0, d/f)$, write $u = s - d/f$, then approximately $\dot{r} = r(a - cd/f)$, $\dot{u} = -du - der/f$, so the solution tends to this point ($r = u = 0$) if $a/c < d/f$ (so this fixed point is *stable*), but not otherwise. The concept of stability is more involved than naive ideas would suggest and so we will be considering the nature of stability. We use *bifurcation theory* to study the change in stability as parameters are varied. As the stability of fixed points changes the nature of the *phase portraits*, i.e. patterns of solution curves or trajectories, changes. For the Lotka-Volterra system there are three distinct phase portraits possible, depending on the parameters. (Exercise.)

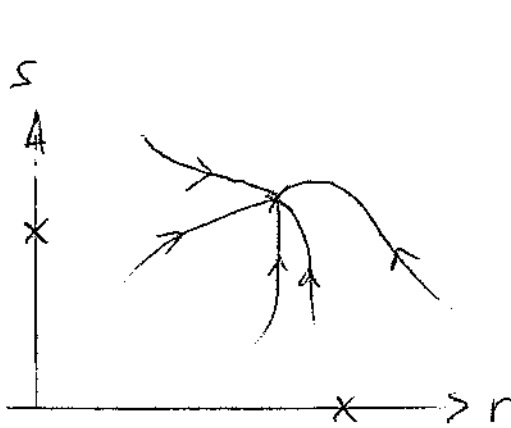

$$c/f < a/d < b/e$$

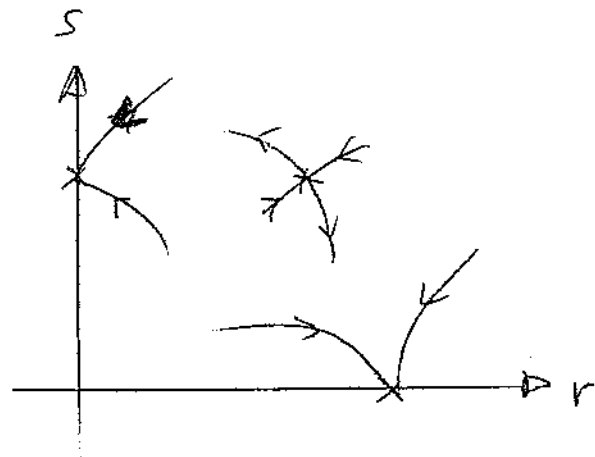

$$b/e < a/d < c/f$$

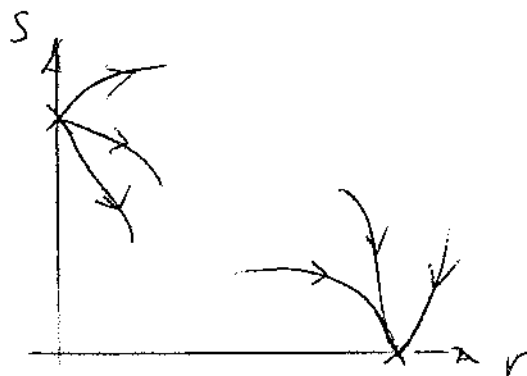

$$b/e, c/f < a/d \quad (\text{I}) \quad (\text{shown})$$

$$a/d < b/e, c/f \quad (\text{II})$$

Other Lotka-Volterra models have different properties, for example the struggle between sheep s and wolves w :

$$\dot{w} = w(-a + bs), \quad \dot{s} = s(c - dw)$$

This system turns out to have *periodic orbits*.

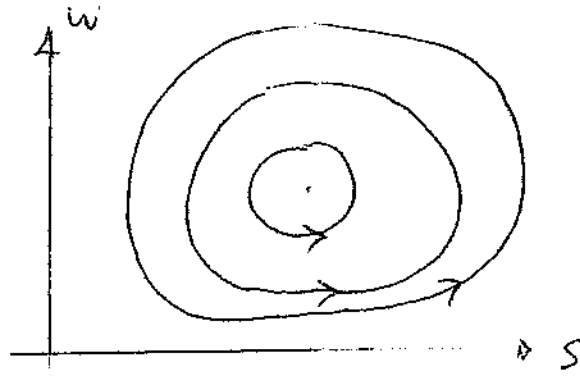

maximum in sheep
leads
maximum in wolves

In 2 dimensions periodic orbits are common for topological reasons, so it will be useful to investigate their stability. Consider the system

$$\dot{x} = -y + \mu x(1 - x^2 - y^2), \quad \dot{y} = x + \mu y(1 - x^2 - y^2)$$

In polar coordinates r, θ , $x = r \cos \theta$, $y = r \sin \theta$ we have

$$\dot{r} = \mu(r - r^3), \quad \dot{\theta} = 1$$

The case $\mu = 0$ is special since there are infinitely many periodic orbits. This is *nonhyperbolic* or not *structurally stable*. Any small change to the value of μ makes a qualitative change in the phase portrait.

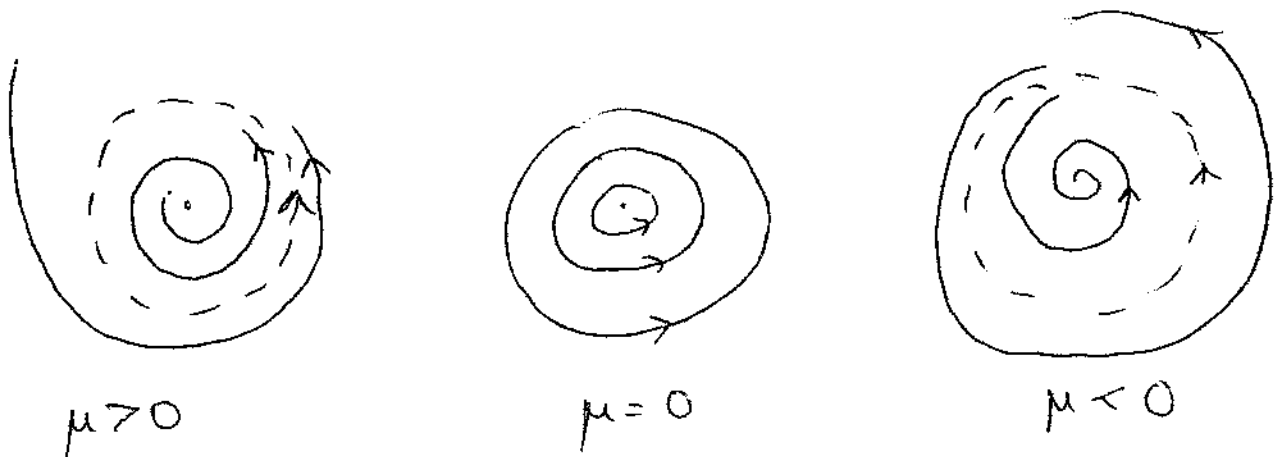

The stability of periodic orbits can be studied in terms of maps. If a solution curve (e.g. in a 3-D phase space) crosses a plane at a point x_n and then crosses again at x_{n+1} this

defines a map of the plane into itself (the *Poincaré map*).

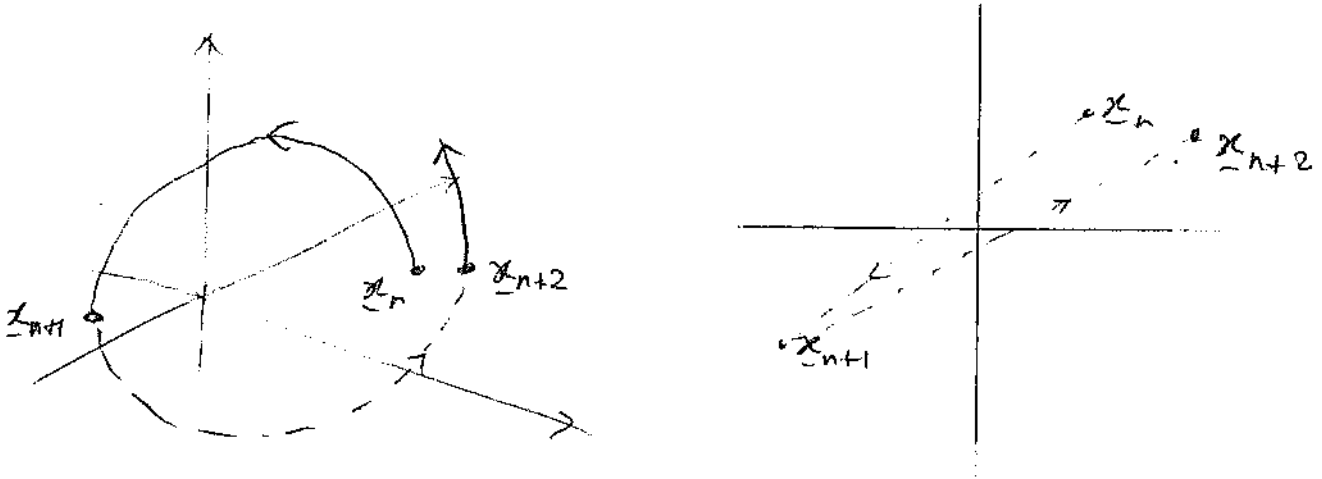

Maps also arise naturally as approximations to flows, e.g. the equation $\dot{x} = \mu x - x^3$ can be approximated using Euler's method (with $x_n = x(n \delta t)$) to give $x_{n+1} = x_n(\mu \delta t + 1) - x_n^3 \delta t$.

Poincaré maps for 3D flows can have many interesting properties including *chaos*. A famous example is the the *Lorenz equations* $\dot{x} = \sigma(y - x)$, $\dot{y} = rx - y - xz$, $\dot{z} = -bz + xy$ (and the corresponding 2-D Poincaré map). For maps, even 1D maps such as the *logistic map* $x_{n+1} = \mu x_n(1 - x_n)$ can have chaotic behaviour.

The Matlab Demo 'lorenz' shows trajectories of the Lorenz equations.

1 Introduction and Basic Definitions

1.1 Elementary concepts

We need some notation to describe our equations.

Define a **State Space** (or **Phase Space**) $E \subseteq \mathbb{R}^n$ (E is sometimes denoted by X). Then the **state** of the system is denoted by $\mathbf{x} \in E$. The state depends on the **time** t and the (ordinary) differential equation gives a rule for the evolution of \mathbf{x} with t :

$$\dot{\mathbf{x}} \equiv \frac{d\mathbf{x}}{dt} = \mathbf{f}(\mathbf{x}, t), \quad (1)$$

where $\mathbf{f} : E \times \mathbb{R} \rightarrow E$ is a vector field.

If $\frac{\partial \mathbf{f}}{\partial t} \equiv 0$ the equation is **autonomous**. The equation is of **order** n . N.B. a system of n first order equations as above is equivalent to an n^{th} order equation in a single dependent variable. If $d^n x/dt^n = g(x, dx/dt, \dots, d^{n-1}x/dt^{n-1})$ then we write $\mathbf{y} = (x, dx/dt, \dots, d^{n-1}x/dt^{n-1})$ and $\dot{\mathbf{y}} = (y_2, y_3, \dots, y_n, g)$.

Non-autonomous equations can be made (formally) autonomous by defining $\mathbf{y} \in E \times \mathbb{R}$ by $\mathbf{y} = (\mathbf{x}, t)$, so that $\dot{\mathbf{y}} = \mathbf{g}(\mathbf{y}) \equiv (\mathbf{f}(\mathbf{y}), 1)$. (We shall assume autonomous unless otherwise stated.)

Example 1 *Second order system $\ddot{x} + \dot{x} + x = 0$ can be written $\dot{x} = y$, $\dot{y} = -x - y$, so $(x, y) \in \mathbb{R}^2$.*

In this course we adopt a *geometric* viewpoint: rather than solving equations in terms of “elementary” (a.k.a. tabulated) functions, look for general properties of the solutions. Since almost all equations cannot be solved in terms of elementary functions, this is more productive!

1.2 Initial Value Problems

Typically, seek solutions to (1) understood as an **initial value problem**:

Given an initial condition $\mathbf{x}(t_0) = \mathbf{x}_0$ ($\mathbf{x}_0 \in E$, $t_0 \in I \subseteq \mathbb{R}$), find a differentiable function $\mathbf{x}(t)$ for $t \in I$ which remains in E for $t \in I$ and satisfies the initial condition and the differential equation.

For an autonomous system we can alternatively define the solution in terms of a flow ϕ_t :

Definition 1 (*Flow*) $\phi_t(\mathbf{x})$ s.t. $\phi_t(\mathbf{x}_0)$ is the solution at time t of $\dot{\mathbf{x}} = \mathbf{f}(\mathbf{x})$ starting at \mathbf{x}_0 when $t = 0$ is called the **flow** through \mathbf{x}_0 at $t = 0$. Thus $\phi_0(\mathbf{x}_0) = \mathbf{x}_0$, $\phi_s(\phi_t(\mathbf{x}_0)) = \phi_{s+t}(\mathbf{x}_0)$ etc. (Continuous semi-group). We sometimes write $\phi_t^{\mathbf{f}}(\mathbf{x}_0)$ to identify the particular dynamical system leading to this flow.

Does such a solution exist? And is it unique?

Existence is guaranteed for many sensible functions by the ****Cauchy-Peano theorem****:

Theorem 1 (Cauchy-Peano). If $f(x, t)$ is continuous and $|f| < M$ in the domain $\mathcal{D} : \{|t - t_0| < \alpha, |x - x_0| < \beta\}$, then the initial value problem above has a solution for $|t - t_0| < \min(\alpha, \beta/M)$.

But *uniqueness* is guaranteed only for stronger conditions on f .

Example 2 Unique solution: $\dot{x} = |x|$, $x(t_0) = x_0$. Then $x(t) = x_0 e^{t-t_0}$ ($x_0 > 0$), $x(t) = x_0 e^{t_0-t}$ ($x_0 < 0$), $x(t) = 0$ ($x_0 = 0$). Here f is not differentiable, but it is continuous.

Example 3 Non-unique solution: $\dot{x} = |x|^{\frac{1}{2}}$, $x(t_0) = x_0$. We still have f continuous. Solving gives $x(t) = (t + c)^2/4$ ($x > 0$) or $x(t) = -(c - t)^2/4$ ($x < 0$). So for $x_0 > 0$, for example, we have $x(t) = (t - t_0 + \sqrt{4x_0})^2/4$ ($t > t_0$). However for $x_0 = 0$ we have two solutions: $x(t) = 0$ and $x(t) = (t - t_0)|t - t_0|/4$ both valid for all t and both matching the initial condition at $t = t_0$.

Why are these different? Because in second case derivatives of $|x|^{\frac{1}{2}}$ are not bounded at the origin. To guarantee uniqueness of solutions need stronger property than continuity; function to be Lipschitz.

Definition 2 (Lipschitz property). A function f defined on a subset of \mathbb{R}^n satisfies a Lipschitz condition at a point x_0 with Lipschitz constant L if $\exists(L, a)$ such that $\forall x, y$ with $|x - x_0| < a, |y - x_0| < a, |f(x) - f(y)| \leq L|x - y|$.

Note that Differentiable \rightarrow Lipschitz \rightarrow Continuous.

We can now state the result (discussed in Part IA also):

Theorem 2 (Uniqueness theorem). Consider an initial value problem to the system (1) with $x = x_0$ at $t = t_0$. If f satisfies a Lipschitz condition at x_0 then the solution $\phi_{t-t_0}(x_0)$ exists and is unique and continuous in a neighbourhood of (x_0, t_0)

Note that uniqueness and continuity do not mean that solutions exist for all time!

Example 4 (Finite time blowup). $\dot{x} = x^3$, $x \in \mathbb{R}$, $x(0) = 1$. This is solved by $x(t) = 1/\sqrt{1 - 2t}$, so $x \rightarrow \infty$ when $t \rightarrow \frac{1}{2}$.

This does not contradict earlier result [why not?] .

From now on consider differentiable functions f unless stated otherwise.

1.3 Trajectories and Flows

Consider the o.d.e. $\dot{x} = f(x)$ with $x(0) = x_0$, or equivalently the flow $\phi_t(x_0)$

Definition 3 (Orbit). The orbit of ϕ_t through x_0 is the set $\mathcal{O}(x_0) \equiv \{\phi_t(x_0) : -\infty < t < \infty\}$. This is also called the trajectory through x_0 .

Definition 4 (Forwards orbit). The forwards orbit of ϕ_t through x_0 is $\mathcal{O}^+(x_0) \equiv \{\phi_t(x_0) : t \geq 0\}$; backwards orbit \mathcal{O}^- defined similarly for $t \leq 0$.

Note that flows and maps can be linked by considering $x_{n+1} = \phi_{\delta t}(x_n)$.

1.4 Invariant and Limit Sets

Work by considering the phase space E , and the flow $\phi_t(x_0)$, considered as a trajectory (directed line) in the phase space. we are mostly interested in special sets of trajectories, as long-time limits of solutions from general initial conditions. These are called **invariant sets**.

Definition 5 (Invariant set). A set of points $\Lambda \subset E$ is **invariant under f** if $x \in \Lambda \Rightarrow \mathcal{O}(x) \in \Lambda$. (Can also define forward and backward invariant sets in the obvious way).

Clearly $\mathcal{O}(x)$ is invariant. Special cases are;

Definition 6 (Fixed point). The point x_0 is a **fixed point (equilibrium, stationary point, critical point)** if $f(x_0) = 0$. Then $x = x_0$ for all time and $\mathcal{O}(x_0) = x_0$.

Definition 7 (Periodic point). A point x_0 is a **periodic point** if $\phi_T(x_0) = x_0$ for some $T > 0$, but $\phi_t(x_0) \neq x_0$ for $0 < t < T$. The set $\{\phi_t(x_0) : 0 \leq t < T\}$ is called a **periodic orbit** through x_0 . T is the **period** of the orbit. If a periodic orbit C is **isolated**, so that there are no other periodic orbits in a sufficiently small neighbourhood of C , the periodic orbit is called a **limit cycle**.

Example 5 (Family of periodic orbits). Consider

$$\begin{pmatrix} \dot{x} \\ \dot{y} \end{pmatrix} = \begin{pmatrix} -y^3 \\ x^3 \end{pmatrix}$$

This has solutions of form $x^4 + y^4 = \text{const.}$, so all orbits except the fixed point at the origin are periodic.

Example 6 (Limit cycle). Now consider

$$\begin{pmatrix} \dot{x} \\ \dot{y} \end{pmatrix} = \begin{pmatrix} -y + x(1 - x^2 - y^2) \\ x + y(1 - x^2 - y^2) \end{pmatrix}$$

Here we have $\dot{r} = r(1 - r^2)$, where $r^2 = x^2 + y^2$. There are no fixed points except the origin and there is a unique limit cycle $r = 1$.

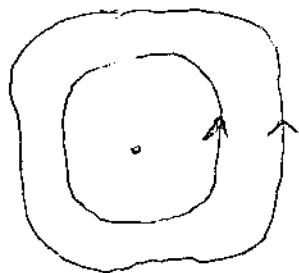

Example 5 - no limit cycles

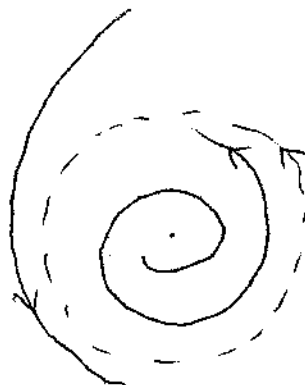

Example 6 - stable limit cycle

Definition 8 (Homoclinic and heteroclinic orbits). If x_0 is a fixed point and $\exists y \neq x_0$ such that $\phi_t(y) \rightarrow x_0$ as $t \rightarrow \pm\infty$, then $\mathcal{O}(y)$ is called a **homoclinic orbit**. If there are two fixed points x_0, x_1 and $\exists y \neq x_0, x_1$ such that $\phi_t(y) \rightarrow x_0$ ($t \rightarrow -\infty$), $\phi_t(y) \rightarrow x_1$ ($t \rightarrow +\infty$) then $\mathcal{O}(y)$ is a **heteroclinic orbit**. A closed sequence of heteroclinic orbits is called a **heteroclinic cycle** (sometimes also called heteroclinic orbit!)

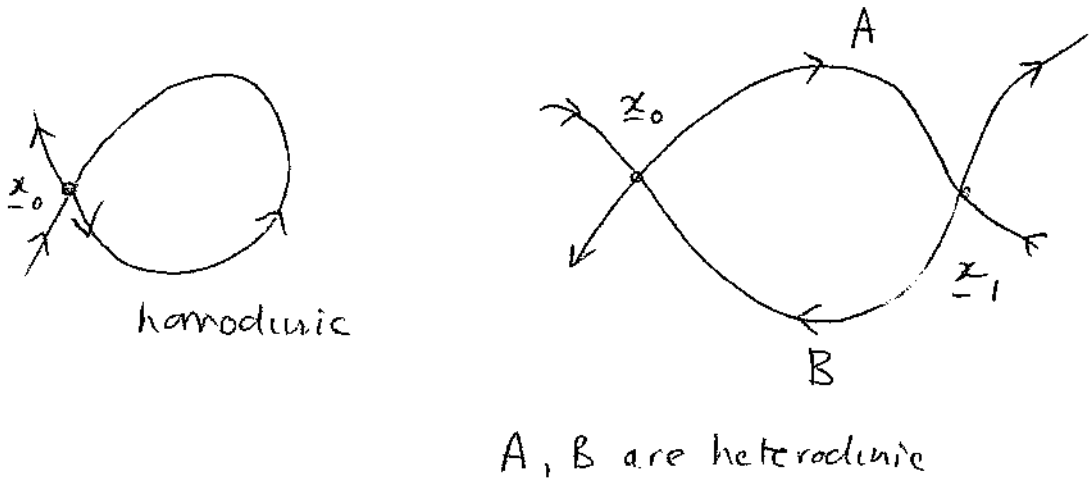

When the phase space has dimension greater than 2 more exotic invariant sets are possible.

Example 7 (2-Torus). let θ_1, θ_2 be coordinates on the surface of a 2-torus, such that $\dot{\theta}_1 = \omega_1, \dot{\theta}_2 = \omega_2$. If ω_1, ω_2 are not rationally related the trajectory comes arbitrarily close to any point on the torus.

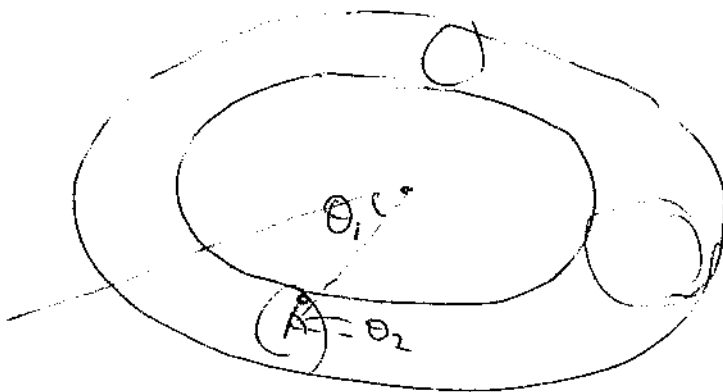

Example 8 (Strange Attractor). Anything more complicated than above is called a *strange attractor*. Examples include the *Lorenz attractor*.

Try the Matlab `lorenz` demo again. Note the term 'attractor' is justified by the fact that trajectories tend to a set which occupies a 'small' part of phase space (a part which has dimension less than 3). The term 'strange' is justified by the complex structure of the attractor which has a fractal nature.

We have to be careful in defining how invariant sets arise as limits of trajectories. Not enough to have definition like "set of points \mathbf{y} s.t. $\phi_t(\mathbf{x}) \rightarrow \mathbf{y}$ as $t \rightarrow \infty$ ", as that does not include e.g. limit cycles. Instead use the following:

Definition 9 (Limit set). The ω -limit set of \mathbf{x} , denoted by $\omega(\mathbf{x})$ is defined by $\omega(\mathbf{x}) \equiv \{\mathbf{y} : \phi_{t_n}(\mathbf{x}) \rightarrow \mathbf{y} \text{ for some sequence of times } t_1, t_2, \dots, t_n, \dots \rightarrow \infty\}$. Can also define α -limit set by sequences $\rightarrow -\infty$.

The ω -limit set $\omega(\mathbf{x})$ has nice properties when $\mathcal{O}(\mathbf{x})$ is bounded: In particular, $\omega(\mathbf{x})$ is:

(a) Non-empty [every sequence of points in a closed bounded domain has at least one accumulation point] (b) Invariant under f [Obvious from definition] (c) Closed [think about limit of a sequence of points in $\omega(\mathbf{x})$] and bounded (d) Connected [Assume not, consider two points in the two separate parts of $\omega(\mathbf{x})$, then a sequence where alternate members tend to each of the two points. Sufficiently far in the sequence, the parts of the orbit between alternate members then contain points that lie outside of $\omega(\mathbf{x})$.]

1.5 Topological equivalence and structural stability

What do we mean by saying that two flows (or maps) have essentially the same (topological/geometric) structure? Or that the structure of a flow changes at a bifurcation?

Definition 10 (Topological Equivalence). Two flows $\phi_t^f(\mathbf{x})$ and $\phi_t^g(\mathbf{y})$ are *topologically equivalent* if there is a homeomorphism $\mathbf{h}(\mathbf{x}) : E^f \rightarrow E^g$ (i.e. a continuous bijection with continuous inverse) and time-increasing function $\tau(\mathbf{x}, t)$ (i.e. a continuous, monotonic function of t) with

$$\phi_t^f(\mathbf{x}) = \mathbf{h}^{-1} \circ \phi_{\tau}^g \circ \mathbf{h}(\mathbf{x}) \quad \text{and} \quad \tau(\mathbf{x}, t_1 + t_2) = \tau(\mathbf{x}, t_1) + \tau(\phi_{t_1}^f(\mathbf{x}), t_2)$$

In other words it is possible to find a map \mathbf{h} from one phase space to the other, and a map τ from time in one phase space to time in the other, in such a way that the evolution of the two systems are the same. Clearly topological equivalence maps fixed points to fixed points, and periodic orbits to periodic orbits – though not necessarily of the same period. A stronger condition is *topological conjugacy*, where time is preserved, i.e. $\tau(\mathbf{x}, t) = t$.

Example 9 The dynamical systems

$$\begin{aligned} \dot{r} &= -r & \text{and} & & \dot{\rho} &= -2\rho \\ \dot{\theta} &= 1 & & & \dot{\psi} &= 0 \end{aligned}$$

are topologically equivalent with $h(0) = 0$, $h(r, \theta) = (r^2, \theta + \ln r)$ for $r \neq 0$ in polar coordinates, and $\tau(x, t) = t$. To show this, integrate the ODEs to get

$$\phi_t^f(r_0, \theta_0) = (r_0 e^{-t}, \theta_0 + t), \quad \phi_t^g(\rho_0, \psi_0) = (\rho_0 e^{-2t}, \psi_0)$$

and check

$$h \circ \phi_t^f = (r_0^2 e^{-2t}, \theta_0 + \ln r_0) = \phi_t^g \circ h$$

(Note that in this case the two systems are also *topologically conjugate*.)

Example 10 *The dynamical systems*

$$\begin{array}{l} \dot{r} = 0 \\ \dot{\theta} = 1 \end{array} \quad \text{and} \quad \begin{array}{l} \dot{r} = 0 \\ \dot{\theta} = r + \sin^2 \theta \end{array}$$

are topologically equivalent. This should be obvious because the trajectories are the same *conjugate* and so we can put $h(x) = x$. Then stretch timescale. (Note *not* topologically equivalent - because periods vary in second.)

Definition 11 ***(Structural Stability)***. The vector field f [system $\dot{x} = f(x)$ or flow $\phi_t^f(x)$] is *structurally stable* if $\exists \epsilon > 0$ s.t. $f + \delta$ is topologically equivalent to f $\forall \delta(x)$ with $|\delta| + \sum_i |\partial \delta / \partial x_i| < \epsilon$.

Examples: The first system above is structurally stable. The second is not (since the periodic orbits are destroyed by a small perturbation $\dot{r} \neq 0$).

2 Flows in \mathbb{R}^2

2.1 Linearization

In analyzing the behaviour of nonlinear systems the first step is to identify the fixed points. Then near these fixed points, behaviour should approximate linear. In fact near a fixed point \mathbf{x}_0 s.t. $\mathbf{f}(\mathbf{x}_0) = 0$, let $\mathbf{y} = \mathbf{x} - \mathbf{x}_0$; then $\dot{\mathbf{y}} = \mathbf{A}\mathbf{y} + O(|\mathbf{y}|^2)$, where $A_{ij} = \left. \frac{\partial f_i}{\partial x_j} \right|_{\mathbf{x}=\mathbf{x}_0}$ is the **linearization of \mathbf{f} about \mathbf{x}_0** . The matrix \mathbf{A} is also written $D\mathbf{f}$, the **Jacobian matrix** of \mathbf{f} at \mathbf{x}_0 . We hope that in general the flow near \mathbf{x}_0 is topologically equivalent to the linearized problem. This is not always true, as shown below.

2.2 Classification of fixed points

Consider general linear system $\dot{\mathbf{x}} = \mathbf{A}\mathbf{x}$, where \mathbf{A} is a constant matrix. We need the eigenvalues $\lambda_{1,2}$ of the matrix, given by $\lambda^2 - \lambda \text{TrA} + \text{DetA} = 0$. This has solutions $\lambda = \frac{1}{2}\text{TrA} \pm \sqrt{\frac{1}{4}(\text{TrA})^2 - \text{DetA}}$. We can then classify the roots into classes.

- **Saddle point** ($\text{DetA} < 0$). Roots are real and of opposite sign.
E.g. $\begin{pmatrix} -2 & 0 \\ 0 & 1 \end{pmatrix}, \begin{pmatrix} 0 & 3 \\ 1 & 0 \end{pmatrix}$; (canonical form $\begin{pmatrix} \lambda_1 & 0 \\ 0 & \lambda_2 \end{pmatrix}$: $\lambda_1 \lambda_2 < 0$.)

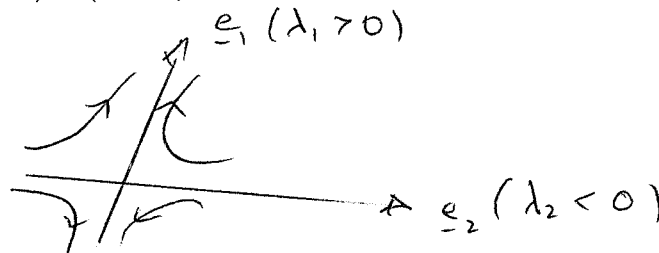

- **Node** ($(\text{TrA})^2 > 4\text{DetA} > 0$). Roots are real and either both positive ($\text{TrA} > 0$: *unstable, repelling node*), or both negative ($\text{TrA} < 0$: *stable, attracting node*).

E.g. $\begin{pmatrix} 2 & 0 \\ 0 & 1 \end{pmatrix}, \begin{pmatrix} 0 & 1 \\ -1 & -3 \end{pmatrix}$; (canonical form $\begin{pmatrix} \lambda_1 & 0 \\ 0 & \lambda_2 \end{pmatrix}$: $\lambda_1 \lambda_2 > 0$.)

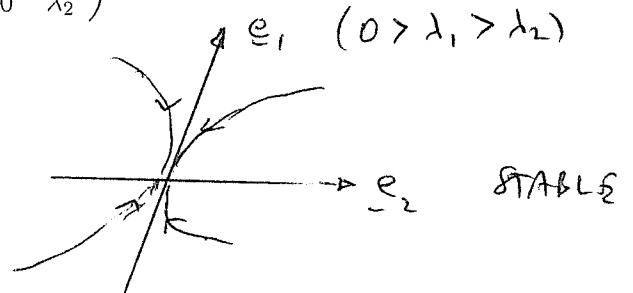
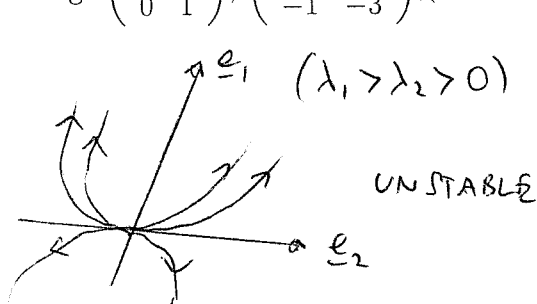

- **Focus (Spiral)** ($(\text{TrA})^2 < 4\text{DetA}$). Roots are complex and either both have positive real part ($\text{TrA} > 0$: *unstable, repelling focus*), or both negative real part ($\text{TrA} < 0$:

stable, attracting focus).

E.g. $\begin{pmatrix} -1 & 1 \\ -1 & -1 \end{pmatrix}$, $\begin{pmatrix} 2 & 1 \\ -2 & 3 \end{pmatrix}$; (canonical form $\begin{pmatrix} \lambda & \omega \\ -\omega & \lambda \end{pmatrix}$: eigenvalues $\lambda \pm i\omega$.)

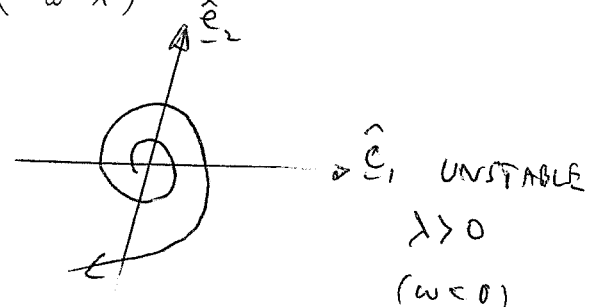
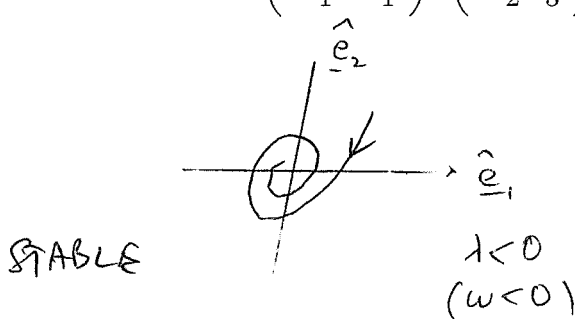

Degenerate cases occur when two eigenvalues are equal ($(\text{Tr}A)^2 = 4\text{Det}A \neq 0$) giving either **Star/Stellar nodes**, e.g. $\begin{pmatrix} 1 & 0 \\ 0 & 1 \end{pmatrix}$ or **Improper nodes** e.g. $\begin{pmatrix} 1 & 1 \\ 0 & 1 \end{pmatrix}$.

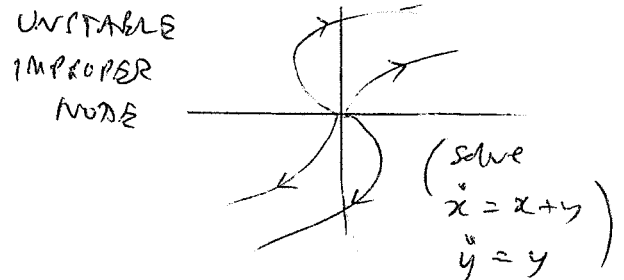
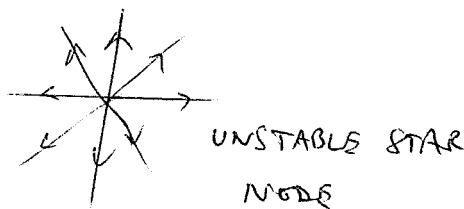

In all these cases the fixed point is **hyperbolic**.

Definition 12 (Hyperbolic fixed point). A fixed point \mathbf{x} of a dynamical system is **hyperbolic** iff all the eigenvalues of the linearization A of the system about \mathbf{x} have non-zero real part.

This definition holds for higher dimensions too.

Thus the nonhyperbolic cases, which are of great importance in bifurcation theory, are those for which at least one eigenvalue has zero real part. These are of three kinds:

- $A = 0$. Both eigenvalues are zero.
- $\text{Det}A = 0$. Here one eigenvalue is zero and we have a line of fixed points. e.g. $\begin{pmatrix} 0 & 0 \\ 0 & -1 \end{pmatrix}$
- $\text{Tr}A = 0$, $\text{Det}A > 0$ (**Centre**). Here the eigenvalues are $\pm i\omega$ and trajectories are closed curves, e.g. $\begin{pmatrix} 0 & 2 \\ -1 & 0 \end{pmatrix}$.

All this can be summarized in a diagram

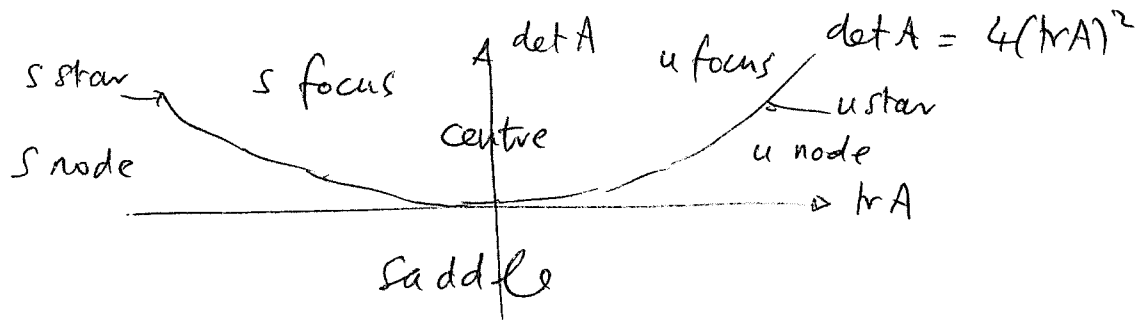

To find canonical form, find the *eigenvectors* of A and use as basis vectors (possibly generalised if eigenvalues equal), when eigenvalues real. For complex eigenvalues in \mathbb{R}^2 we have two complex eigenvectors e, e^* so use $\{Re(e), Im(e)\}$ as a basis. This can help in drawing trajectories. But note classification is independent of basis.

Centres are special cases in context of general flows; but *Hamiltonian systems* have centres generically. These systems have the form $\dot{x} = (H_y, -H_x)$ for some $H = H(x, y)$. At a fixed point $\nabla H = 0$, and the matrix

$$A = \begin{pmatrix} H_{xy} & H_{yy} \\ -H_{xx} & -H_{xy} \end{pmatrix} \Rightarrow \text{Tr}A = 0.$$

Thus all fixed points are saddles or centres. Clearly also $\dot{x} \cdot \nabla H = 0$, so H is constant on all trajectories, i.e. trajectories are contours of $H(x, y)$

2.3 Effect of nonlinear terms

For a general nonlinear system $\dot{x} = f(x)$, we start by locating the fixed points, x_0 , where $x_0 = 0$. Then what does the linearization of the system about the fixed point x_0 tell us about the behaviour of the nonlinear system?

We can show (e.g. Glendinning Ch. 4) that if

- (i) x_0 is hyperbolic; and
- (ii) the nonlinear corrections are $O(|x - x_0|^2)$,

then the nonlinear system and the linearized system are topologically conjugate.

We thus discuss separately hyperbolic and non-hyperbolic fixed points.

2.3.1 Stable and Unstable Manifolds

For the *linearized* system we can separate the phase space into different domains corresponding to different behaviours in time.

Definition 13 (Invariant subspaces). The *stable, unstable and centre subspaces* of the linearization of f at the fixed point x_0 are the three linear subspaces E^u, E^s, E^c , spanned by the subsets of (possibly generalised) eigenvectors of A whose eigenvalues have real parts $< 0, > 0, = 0$ respectively.

Note that a hyperbolic fixed point has no centre subspace.

These concepts can be extended simply into the nonlinear domain for hyperbolic fixed points. We suppose that the fixed point is at the origin and that \mathbf{f} is expandable in a Taylor series. We can write $\dot{\mathbf{x}} = \mathbf{A}\mathbf{x} + \mathbf{f}(\mathbf{x})$, where $\mathbf{f} = O(|\mathbf{x}|^2)$. We need the **Stable (or Invariant) Manifold Theorem**.

Theorem 3 (*Stable (or Invariant) Manifold Theorem*). *Suppose 0 is a hyperbolic fixed point of $\dot{\mathbf{x}} = \mathbf{f}(\mathbf{x})$, and that E^u, E^s are the unstable and stable subspaces of the linearization of \mathbf{f} about 0. Then \exists local stable and unstable manifolds $W_{loc}^u(0), W_{loc}^s(0)$, which have the same dimension as E^u, E^s and are tangent to E^u, E^s at 0, such that for $\mathbf{x} \neq 0$ but in a sufficiently small neighbourhood of 0,*

$$W_{loc}^u = \{\mathbf{x} : \phi_t(\mathbf{x}) \rightarrow 0 \text{ as } t \rightarrow -\infty\}$$

$$W_{loc}^s = \{\mathbf{x} : \phi_t(\mathbf{x}) \rightarrow 0 \text{ as } t \rightarrow +\infty\}$$

Proof: rather involved; see Glendinning, p.96. The trick is to produce a near identity change of coordinates. Suppose that for each \mathbf{x} , $\mathbf{x} = \mathbf{y} + \mathbf{z}$, where $\mathbf{y} \in E^u$ and $\mathbf{z} \in E^s$. The linearized stable manifold is therefore $\mathbf{y} = 0$ and the linearized unstable manifold is $\mathbf{z} = 0$. We look for the stable manifold in the form $\mathbf{y} = \mathbf{S}(\mathbf{z})$; then make a change of variable $\boldsymbol{\xi} = \mathbf{y} - \mathbf{S}(\mathbf{z})$ so that the transformed equation has $\boldsymbol{\xi} = 0$ as an invariant manifold. The function $\mathbf{S}(\mathbf{z})$ can be expanded as a power series, and the idea is to check that the expansion can be performed to all orders, giving a finite (i.e. non-zero) radius of convergence. The unstable manifold can be constructed in a similar way.

The local stable manifold W_{loc}^s can be extended to a *global invariant manifold* W^s by following the flow backwards in time from points in W_{loc}^s . Correspondingly W_{loc}^u can also be extended to a global invariant manifold.

It is easy to find approximations to the stable and unstable manifolds of a saddle point in \mathbb{R}^2 . The stable (say) manifold must tend to the origin and be tangent to the stable subspace E^s (i.e. to the eigenvector corresponding to the negative eigenvalue). (It is often easiest though not necessary to change to coordinates such that $x = 0$ or $y = 0$ is tangent to the manifold). Then for example if we want to find the manifold (for 2D flows just a trajectory) that is tangent to $y = 0$ at the origin for the system $\dot{x} = f(x, y)$, $\dot{y} = g(x, y)$, write $y = p(x)$; then

$$g(x, p(x)) = \dot{y} = p'(x)\dot{x} = p'(x)f(x, p(x)),$$

which gives a nonlinear ODE for $p(x)$. In general this cannot be solved exactly, but we can find a (locally convergent) series expansion in the form $p(x) = a_2x^2 + a_3x^3 + \dots$, and solve term by term.

Example 11 Consider $\begin{pmatrix} \dot{x} \\ \dot{y} \end{pmatrix} = \begin{pmatrix} x \\ -y + x^2 \end{pmatrix}$. This can be solved exactly to give $x = x_0e^t$, $y = \frac{1}{3}x_0^2e^{2t} + (y_0 - \frac{1}{3}x_0^2)e^{-t}$ or $y(x) = \frac{1}{3}x^2 + (y_0 - \frac{1}{3}x_0^2)x_0x^{-1}$. Two obvious invariant curves are $x = 0$ and $y = \frac{1}{3}x^2$, and $x = 0$ is clearly the stable manifold. The linearization

about 0 gives the matrix $A = \begin{pmatrix} 1 & 0 \\ 0 & -1 \end{pmatrix}$ and so the unstable manifold must be tangent to $y = 0$; $y = \frac{1}{3}x^2$ fits the bill. To find constructively write $y(x) = a_2x^2 + a_3x^3 + \dots$. Then

$$\frac{dy}{dt} = \dot{x} \frac{dy}{dx} = (2a_2x + 3a_3x^2 + \dots)x = -a_2x^2 - a_3x^3 + \dots + x^2$$

Equating coefficients, find $a_2 = \frac{1}{3}$, $a_3 = 0$, etc.

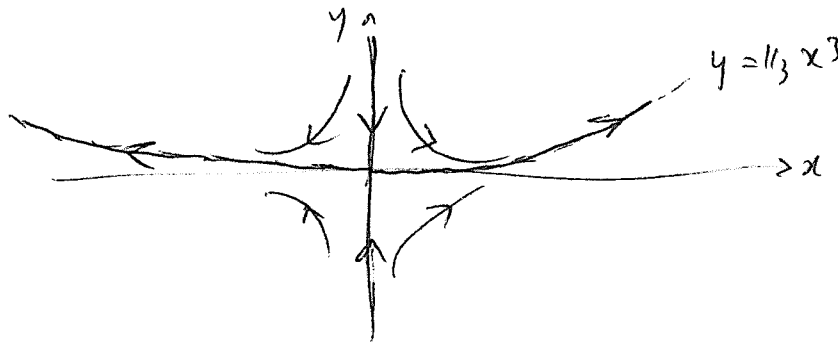

Example 12 Now $\begin{pmatrix} \dot{x} \\ \dot{y} \end{pmatrix} = \begin{pmatrix} x - xy \\ -y + x^2 \end{pmatrix}$; there is no simple form for the unstable manifold (stable manifold is still $x = 0$). The unstable manifold has the form $y = ax^2 + bx^3 + cx^4 + \dots$, where [exercise] $a = \frac{1}{3}$, $b = 0$, $c = \frac{2}{45}$, etc. Note that this infinite series (in powers of x^2) has a finite radius of convergence since the unstable manifold of the origin is attracted to a stable focus at $(1, 1)$.

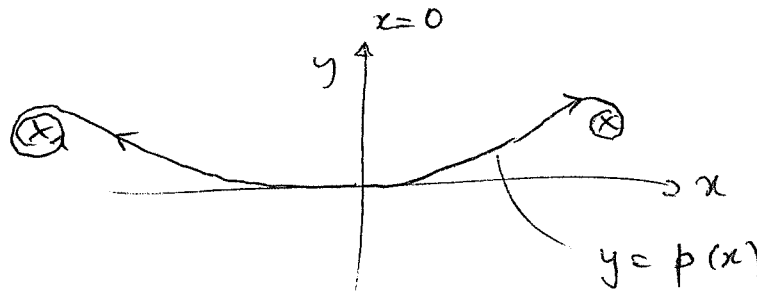

2.3.2 Nonlinear terms for non-hyperbolic cases

We now suppose that there is at least one eigenvalue on the imaginary axis. Concentrate on \mathbb{R}^2 , generalization not difficult. There are two possibilities:

- (i) A has eigenvalues $\pm i\omega$. The linear system is a centre. The nonlinear systems have different forms for different r.h.s.'s

- Stable focus: $\begin{pmatrix} -y - x^3 \\ x - y^3 \end{pmatrix}$

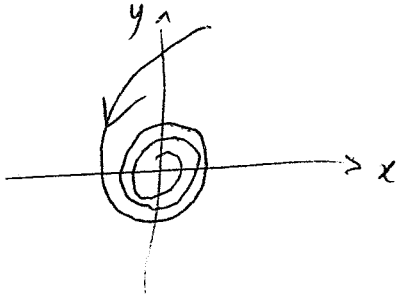

$$r\dot{r} = -x^4 - y^4 = -r^4 (\cos^4\theta + \sin^4\theta)$$

$$r^2\dot{\theta} = x^2 - xy^3 + y^2 + x^3y$$

$$= r^2 \{1 + r^3 \sin\theta \cos\theta (\cos^2\theta - \sin^2\theta)\}$$

$$(\dot{\theta} > 0 \text{ for } r^2 < 2)$$

- Unstable focus: $\begin{pmatrix} -y + x^3 \\ x + y^3 \end{pmatrix}$

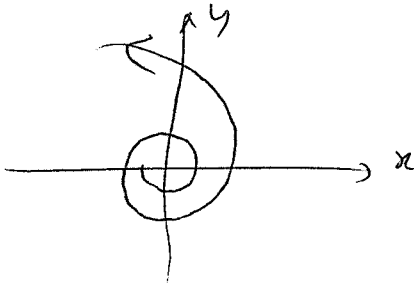

$$r\dot{r} = r^4 (\cos^4\theta + \sin^4\theta)$$

$$r^2\dot{\theta} = 1 - r^2 \sin\theta \cos\theta (\cos^2\theta - \sin^2\theta)$$

- Nonlinear centre: $\begin{pmatrix} -y - 2x^2y \\ x + 2y^2x \end{pmatrix}$

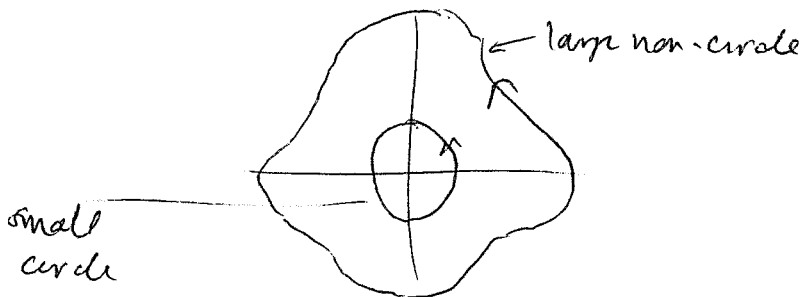

$$\dot{x} = -\frac{\partial}{\partial y}(y^2 + x^2y^2)$$

$$\dot{y} = \frac{\partial}{\partial x}(x^2 + x^2y^2)$$

$$x^2 + y^2 + x^2y^2 \text{ constant}$$

along trajectories

- (ii) A has one zero eigenvalue, other e.v. non-zero, e.g. (a) $\dot{x} = x^2, \dot{y} = -y$ [Saddle-node],
 (b) $\dot{x} = x^3, \dot{y} = -y$ [Nonlinear Saddle].

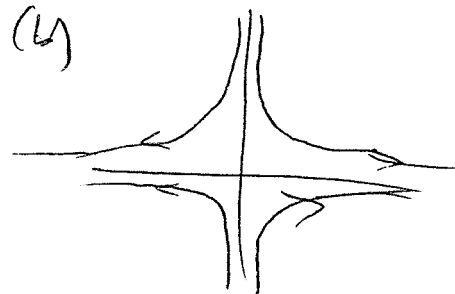
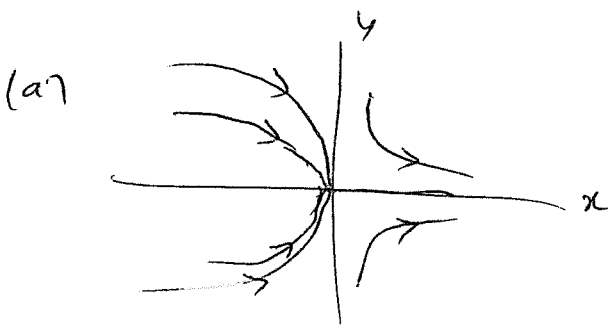

- (iii) Two zero eigenvalues. Here almost anything is possible. Change to polar coords. Find lines as $r \rightarrow 0$ on which $\dot{\theta} = 0$. Between each of these lines can have three different

types of behaviour. (See diagram).

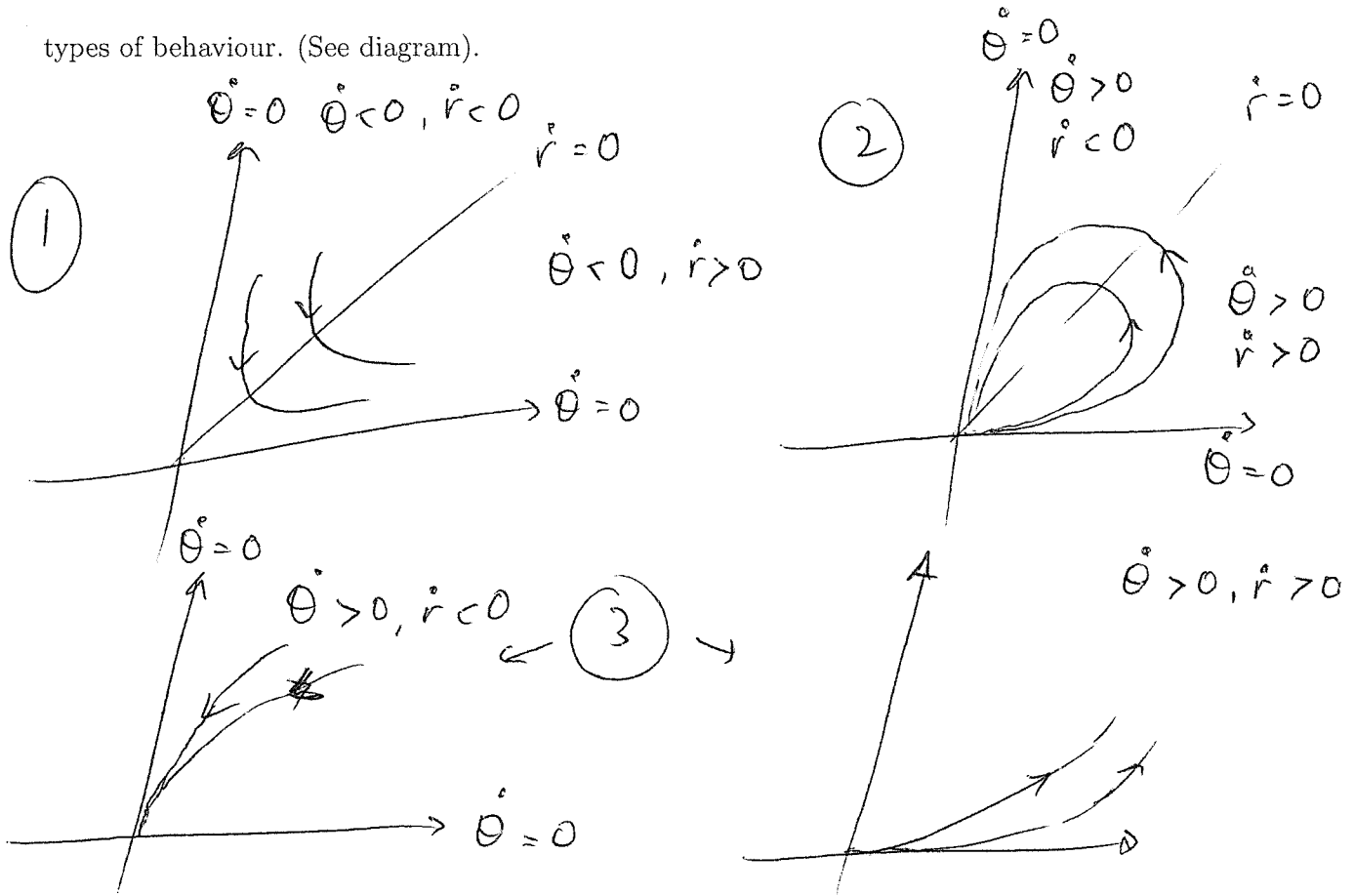

2.4 Sketching phase portraits

This often involves some good luck and good judgement! Nonetheless there are some guidelines which if followed will give a good chance of success. The general procedure is as follows:

- 1. Find the fixed points, and find any obvious invariant lines e.g. $x = 0$ when $\dot{x} = xh(x, y)$ etc.
- 2. Calculate the Jacobian and hence find the type of fixed point. (Accurate calculation of eigenvalues etc. for nodes may not be needed for sufficiently simple systems - just find the type.) Do find eigenvectors for saddles.
- 3. If fixed points non-hyperbolic get local picture by considering nonlinear terms.
- 4. If still puzzled, find nullclines, where \dot{x} or \dot{y} (or \dot{r} or $\dot{\theta}$) are zero.
- 5. Construct global picture by joining up local trajectories near fixed points (especially saddle separatrices) and put in arrows.
- 6. Use results of Section 4 to decide whether there are periodic orbits.

Example 13 (worked example). Consider $\begin{pmatrix} \dot{x} \\ \dot{y} \end{pmatrix} = \begin{pmatrix} x(1-y) \\ -y+x^2 \end{pmatrix}$. Jacobian $A = \begin{pmatrix} 1-y & -x \\ 2x & -1 \end{pmatrix}$.

Fixed points at $(0,0)$ (saddle) and $(\pm 1,1)$; $A = \begin{pmatrix} 0 & \mp 1 \\ \pm 2 & -1 \end{pmatrix}$. $\text{Tr}A^2 = 1 < \text{Det}A$ so stable foci. $x = 0$ is a trajectory, $\dot{x} = 0$ on $y = 1$ and $\dot{y} \leq 0$ when $y \geq x^2$.

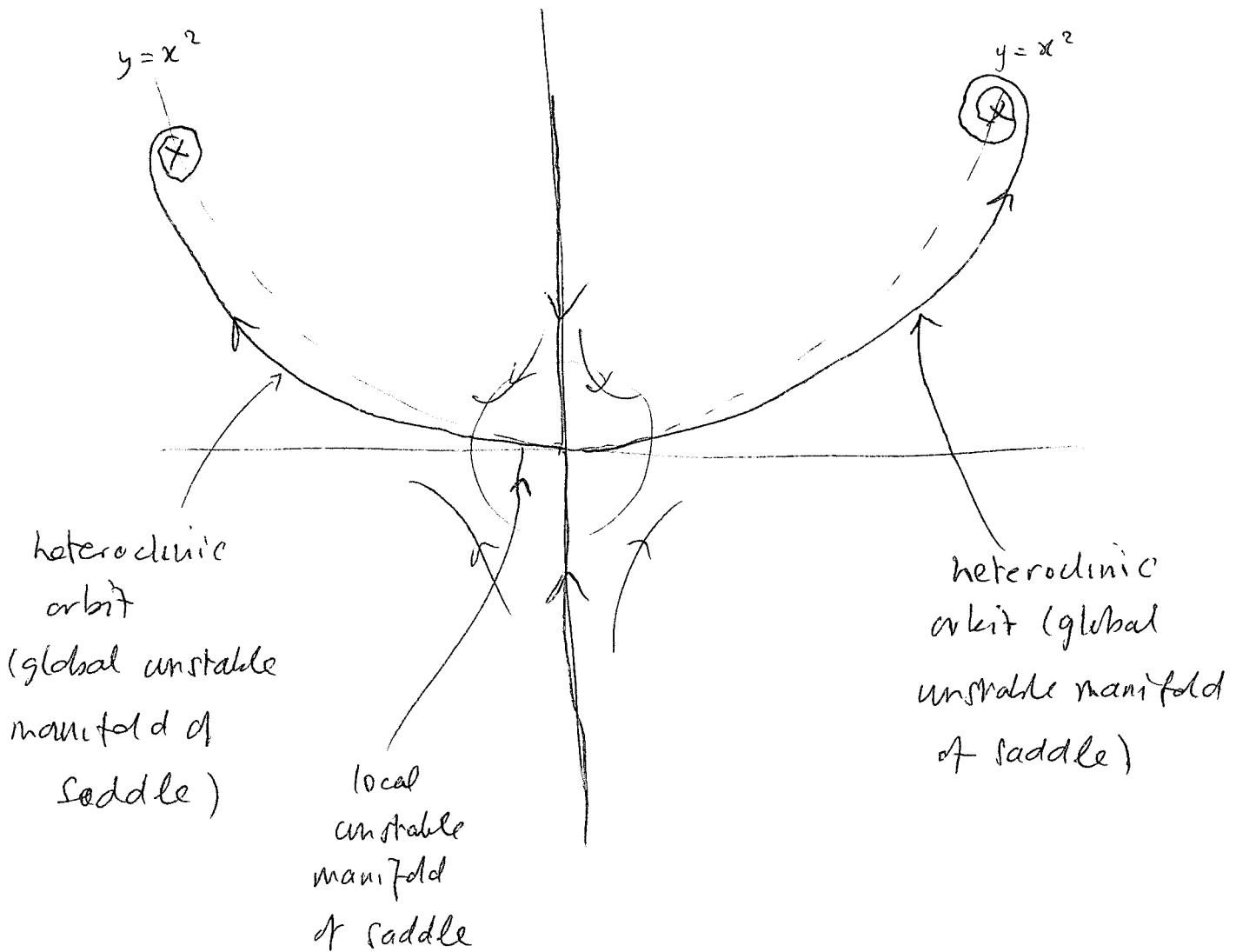

3 Stability

3.1 Definitions of stability

If we find a fixed point, or more generally an invariant set, of a dynamical system we want to know what happens to the system under small perturbations away from the invariant set. We also want to know which invariant sets will be approached at large times. If in some sense the solution stays “nearby”, or the set is approached after long times, then we call the set stable. There are several differing definitions of stability. We will consider stability of whole invariant sets (and not just of points in those sets). This shortens the discussion.

Consider an invariant set Λ in a general (autonomous) dynamical system described by a flow ϕ_t . (This could be a fixed point, periodic orbit, torus etc.) We need a definition of points *near* the set Λ :

Definition 14 (*Neighbourhood of a set Λ*). For $\delta > 0$ the **neighbourhood** $N_\delta(\Lambda) = \{x : \exists y \in \Lambda \text{ s.t. } |x - y| < \delta\}$

We also need to define the concept of a flow trajectory tending to Λ .

Definition 15 (*flow tending to Λ*). The flow $\phi_t(x) \rightarrow \Lambda$ iff $\min_{y \in \Lambda} |\phi_t(x) - y| \rightarrow 0$ as $t \rightarrow \infty$

Definition 16 (*Lyapunov stability*)[LS]. The set Λ is **Lyapunov stable** if $\forall \epsilon > 0 \exists \delta > 0$ s.t. $x \in N_\delta(\Lambda) \Rightarrow \phi_t(x) \in N_\epsilon(\Lambda) \forall t \geq 0$. (“**start near, stay near**”).

Definition 17 (*Quasi-asymptotic stability*)[QAS]. The set Λ is **quasi-asymptotically stable** if $\exists \delta > 0$ s.t. $x \in N_\delta(\Lambda) \Rightarrow \phi_t(x) \rightarrow \Lambda$ as $t \rightarrow \infty$. (“**get close eventually**”).

Definition 18 (*Asymptotic stability*)[AS]. The set Λ is **asymptotically stable** if it is both Lyapunov stable and quasi-asymptotically stable.

Example 14 (*The origin is LS but not QAS*). $\begin{pmatrix} \dot{x} \\ \dot{y} \end{pmatrix} = \begin{pmatrix} -y \\ x \end{pmatrix}$.

All limit sets are circles or the origin.

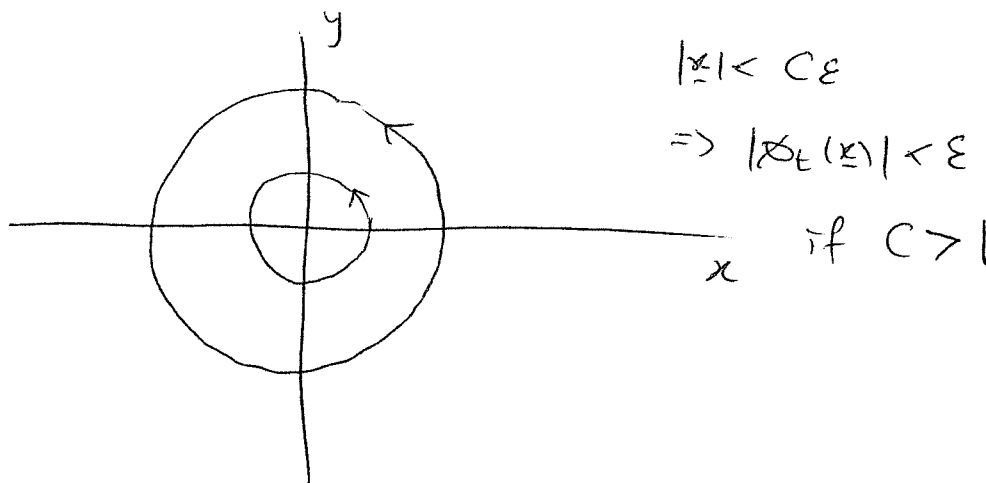

Example 15 (QAS but not LS). $\begin{pmatrix} \dot{r} \\ \dot{\theta} \end{pmatrix} = \begin{pmatrix} r(1-r^2) \\ \sin^2 \frac{\theta}{2} \end{pmatrix}$.

Point $r = 1, \theta = 0$ is a saddle-node.

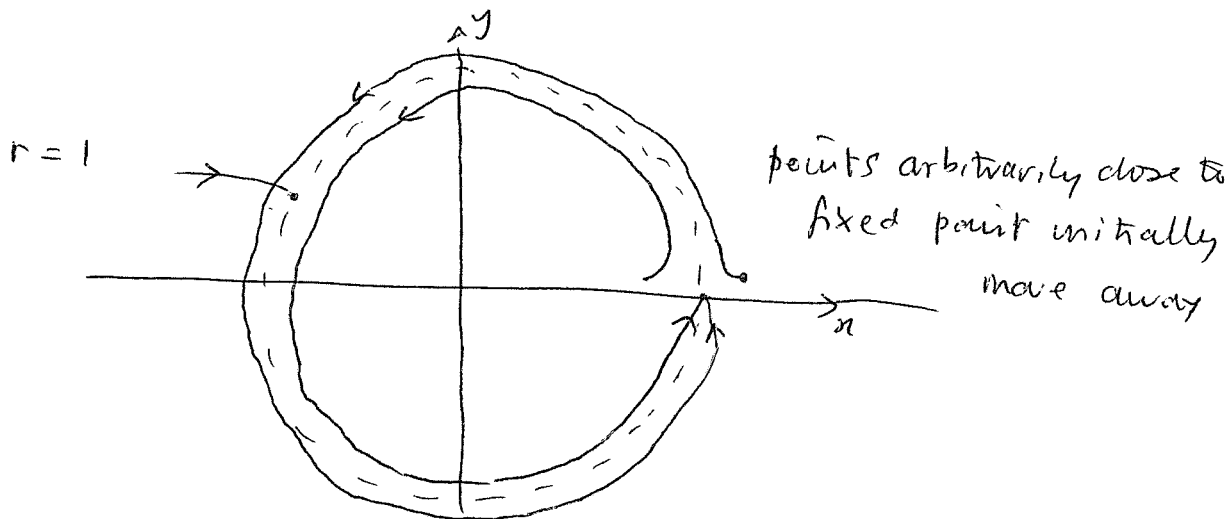

Example 16 $\begin{pmatrix} \dot{x} \\ \dot{y} \end{pmatrix} = \begin{pmatrix} y - \mu x \\ -2\mu y \end{pmatrix}$ ($\mu > 0$). Here $y = y_0 e^{-2\mu t}$, $x = x_0 e^{-\mu t} + y_0 \mu^{-1} (e^{-\mu t} - e^{-2\mu t})$. Thus for $t \geq 0$, $|y| \leq |y_0|$, $|x| \leq |x_0| + \frac{1}{4}\mu^{-1}|y_0|$, and so $x^2 + y^2 \leq (x_0^2 + y_0^2)(1 + \mu^{-1} + \mu^{-2}/16)$. This proves Lyapunov stability. Furthermore the solution clearly tends to the origin as $t \rightarrow \infty$.

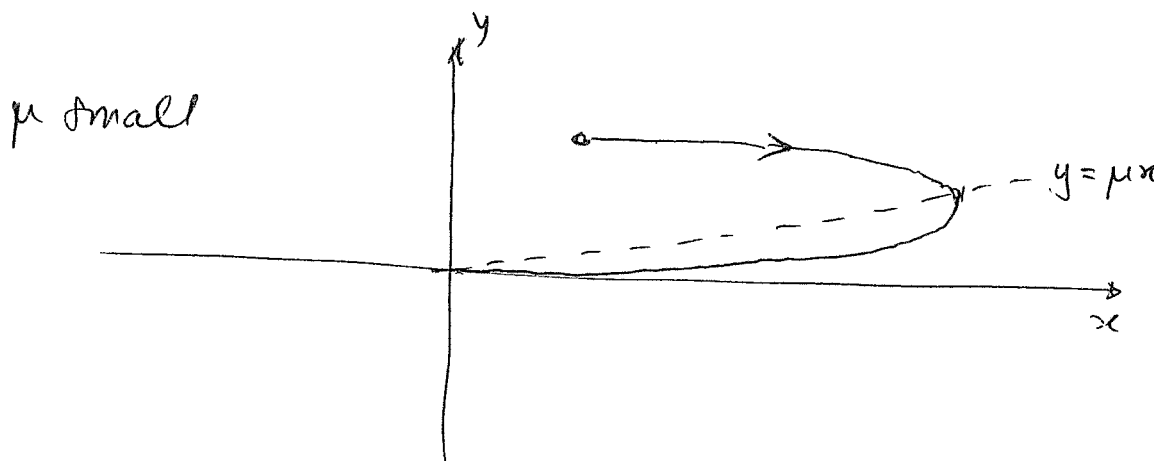

This example is instructive because for μ sufficiently small the solution can grow to large values before eventually decaying. To require that the norm of the solution decays monotonically is a stronger result, only applicable to a small number of problems.

If an invariant set is not LS or QAS we say it is **unstable** (or according to some books, **nonstable**).

There may be more than one asymptotically stable limit set. In that case we want to know what parts of the phase space lead to which limit sets being approached. Then we define the **basin of attraction** (or domain of stability):

Definition 19 If Λ is an asymptotically stable invariant set the **basin of attraction of Λ** , $\mathcal{B}(\Lambda) \equiv \{\mathbf{x} : \phi_t(\mathbf{x}) \rightarrow \Lambda \text{ as } t \rightarrow \infty\}$. If $\mathcal{B}(\Lambda) = \mathbb{R}^n$ then Λ is **globally attracting** (or **globally stable**). Note that $\mathcal{B}(\Lambda)$ is an open set.

When there are many fixed points the basin of attraction can be quite complicated.

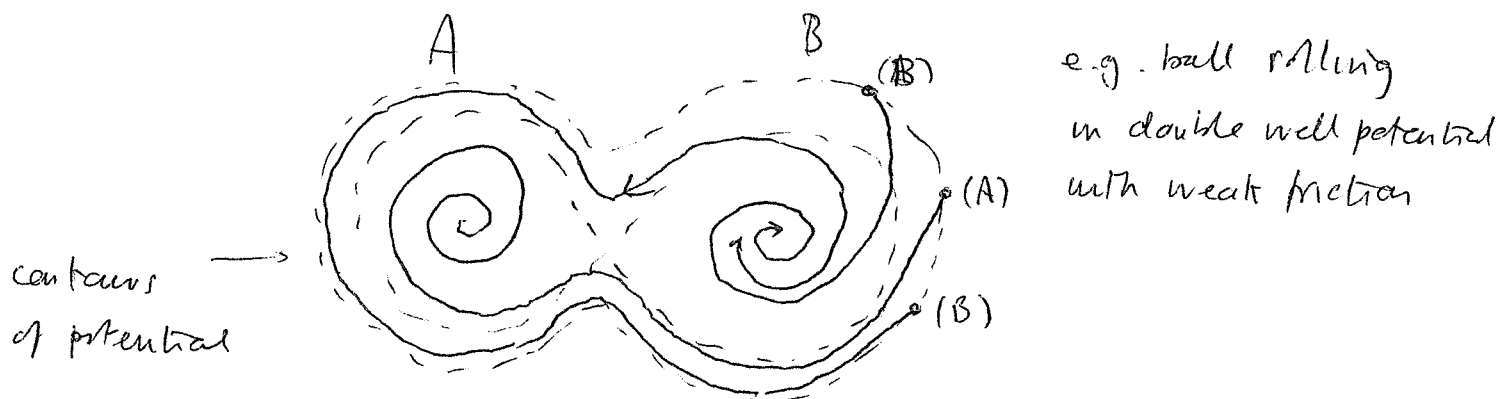

When Λ is an isolated fixed point (\mathbf{x}_0 , say) we can investigate its stability by **linearizing** the system about \mathbf{x}_0 (see previous section of notes).

Theorem 4 (*Stability of hyperbolic fixed points*). If 0 is a hyperbolic stable focus or stable node then it is asymptotically stable. If 0 is a hyperbolic fixed point with at least one eigenvalue with $\text{Re}\lambda > 0$, then it is unstable.

3.2 Lyapunov functions

We can prove much about stability of a fixed point (which, for convenience, will be taken to be at the origin) if we can find a suitable positive function \mathcal{V} of the independent variables that is zero at the origin and decreases monotonically under the flow ϕ_t . Then under certain reasonable conditions we can show that $\mathcal{V} \rightarrow 0$ so that the appropriately defined modulus of the solution similarly tends to zero. This is a **Lyapunov function**, defined precisely by

Definition 20 (*Lyapunov function*). Let E be a closed connected region of \mathbb{R}^n containing the origin. A continuous function $\mathcal{V} : \mathbb{R}^n \rightarrow \mathbb{R}$ which is differentiable except perhaps at the origin is a **Lyapunov function** for a flow ϕ if (i) $\mathcal{V}(0) = 0$, (ii) \mathcal{V} is **positive definite** ($\mathcal{V}(\mathbf{x}) > 0$ when $0 \neq \mathbf{x}$), and if also (iii) $\mathcal{V}(\phi_t(\mathbf{x})) \leq \mathcal{V}(\mathbf{x}) \forall \mathbf{x} \in E$ (or equivalently if $\dot{\mathcal{V}} \leq 0$ on trajectories).

Then we have the following theorems:

Theorem 5 (*Lyapunov's First Theorem [L1]*). Suppose that a dynamical system $\dot{\mathbf{x}} = \mathbf{f}(\mathbf{x})$ has a fixed point at the origin. If a Lyapunov function exists, as defined above, then the origin is Lyapunov stable.

Theorem 6 (Lyapunov's Second Theorem [L2]). *If in addition $\dot{V} < 0$ for $\mathbf{x} \neq 0$ then V is a **Strict Lyapunov function** and the origin is asymptotically stable.*

An important point is that level sets (e.g. contours in 2-D) of $V(\mathbf{x})$ can be used to define neighbourhoods of the origin. In particular, for sufficiently small ϵ , there is an α such that $V(\mathbf{x}) < \alpha$ implies that $|\mathbf{x}| < \epsilon$ and correspondingly there is a β such that $V(\mathbf{x}) > \beta$ implies that $|\mathbf{x}| > \epsilon$.

Proof of First Theorem: We want to show that for any sufficiently small neighbourhood U of the origin, there is a neighbourhood V s.t. if $\mathbf{x}_0 \in V$, $\phi_t(\mathbf{x}_0) \in U$ for all positive t . Let $U = \{\mathbf{x} : |\mathbf{x}| < \epsilon\} \subseteq E$ and let $\alpha = \min\{V(\mathbf{x}) : |\mathbf{x}| = \epsilon\}$. Clearly $\alpha > 0$ from the definition of V . Now consider the set $U_1 = \{\mathbf{x} \in U : V(\mathbf{x}) < \alpha\}$. Certainly U_1 contains the origin, but furthermore there is a $\delta > 0$ such that $V = \{\mathbf{x} : |\mathbf{x}| < \delta\} \subseteq U_1$. Then $\mathbf{x} \in V$ implies that $V(\phi_t(\mathbf{x})) < \alpha \forall t \geq 0$, since V does not increase along trajectories. Hence $(\phi_t(\mathbf{x}))$ does not leave U_1 and hence it does not leave U , as required.

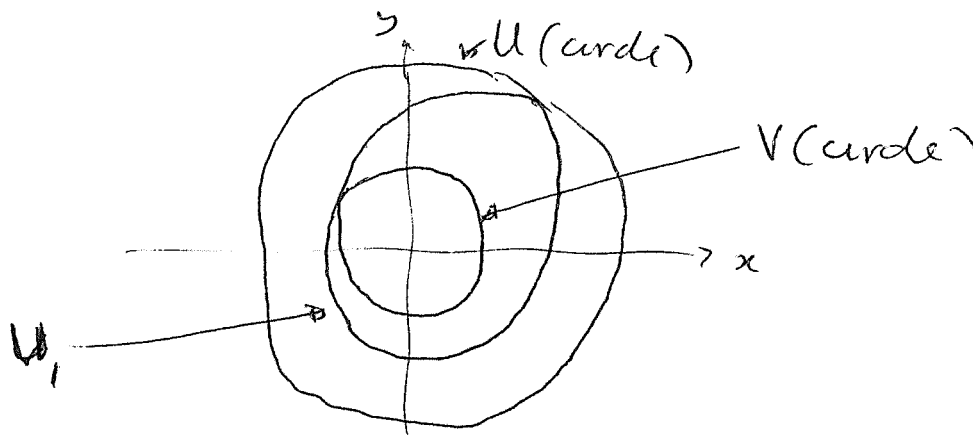

Proof of Second Theorem: [L1] implies that \mathbf{x} remains in the domain U . For any initial point $\mathbf{x}_0 \neq 0$, $V(\mathbf{x}_0) > 0$ and $\dot{V} < 0$ along trajectories. Thus $V(\phi_t(\mathbf{x}_0))$ decreases monotonically and is bounded below by 0. Then $V \rightarrow \alpha \geq 0$; suppose $\alpha > 0$. Then $|\mathbf{x}|$ is bounded away from zero (by continuity of V), and so $\dot{V} < -b < 0$. Thus $V(\phi_t(\mathbf{x}_0)) < V(\mathbf{x}_0) - bt$ and so is certainly negative after a finite time. Thus there is a contradiction, and so $\alpha = 0$. Hence $V \rightarrow 0$ as $t \rightarrow \infty$ and so $|\mathbf{x}| \rightarrow 0$ (again by continuity). This proves asymptotic stability.

To prove results about instability just reverse the sense of time. Sometimes we can demonstrate asymptotic stability even when V is not a strict Lyapunov function. For this need another theorem, **La Salle's Invariance Principle**:

Theorem 7 (La Salle's Invariance Principle). *If V is a Lyapunov function for a flow ϕ then $\forall \mathbf{x}$ such that $\phi_t(\mathbf{x})$ is bounded $\exists c$ s.t. $\omega(\mathbf{x}) \subseteq M_c \equiv \{\mathbf{x} : V(\phi_t(\mathbf{x})) = c \forall t \geq 0\}$. (Or, $\phi_t(\mathbf{x}) \rightarrow$ an invariant subset of the set $\{\mathbf{y} : \dot{V}(\mathbf{y}) = 0\}$.)*

Proof : choose a point \mathbf{x} and let $c = \inf_{t \geq 0} V(\phi_t(\mathbf{x}))$. By assumption $\phi_t(\mathbf{x})$ remains finite and $\omega(\mathbf{x})$ is not empty. Then if $\mathbf{y} \in \omega(\mathbf{x})$, \exists a sequence of times t_n s.t. $\phi_{t_n}(\mathbf{x}) \rightarrow \mathbf{y}$ as $n \rightarrow \infty$, then by continuity of V and since $\dot{V} \leq 0$ on trajectories we have $V(\mathbf{y}) = c$. We

need to prove that $\mathbf{y} \in M_c$ (i.e. that $\mathcal{V}(\phi_t(\mathbf{y})) = c$ for $t \geq 0$). Suppose to the contrary that $\exists s$ s.t. $\mathcal{V}(\phi_s(\mathbf{y})) < c$. Thus for all \mathbf{z} sufficiently close to \mathbf{y} we have $\mathcal{V}(\phi_s(\mathbf{z})) < c$. But if $\mathbf{z} = \phi_{t_n}(\mathbf{x})$ for sufficiently large n we have $\mathcal{V}(\phi_{t_n+s}(\mathbf{x})) < c$, which is a contradiction. This proves the theorem.

As a corollary we note that if \mathcal{V} is a Lyapunov function on a bounded domain D and the only invariant subset of $\{\mathbf{y} : \dot{\mathcal{V}}(\mathbf{y}) = 0\}$ is the origin then the origin is asymptotically stable.

The following are examples of the use of the Lyapunov theorems.

Example 17 (Finding the basin of attraction). Consider $\begin{pmatrix} \dot{x} \\ \dot{y} \end{pmatrix} = \begin{pmatrix} -x + xy^2 \\ -2y + yx^2 \end{pmatrix}$. We can ask: what is the best condition on \mathbf{x} which guarantees that $\mathbf{x} \rightarrow 0$ as $t \rightarrow \infty$? Consider $\mathcal{V}(x, y) = \frac{1}{2}(x^2 + b^2y^2)$ for constant b . Then $\dot{\mathcal{V}} = -(x^2 + 2b^2y^2) + (1 + b^2)x^2y^2$. We can then show easily that $\dot{\mathcal{V}} < 0$ if $\mathcal{V} < (3 + 2\sqrt{2})b^2/2(1 + b^2)$ [Check by setting $z = by$ and using polars for (x, z)]. The domain of attraction of the origin certainly includes the union of these sets over all values of b .

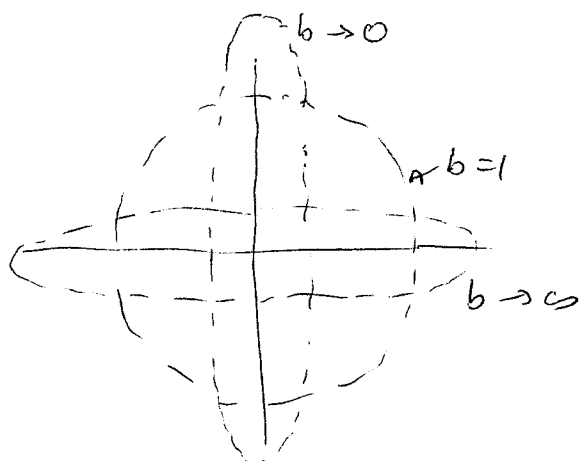

$$\frac{1}{2}(x^2 + b^2y^2) = \mathcal{V} < \frac{3 + 2\sqrt{2}}{2} \frac{b^2}{1 + b^2}$$

ellipse with axes $\frac{(1 + \sqrt{2})b}{\sqrt{1 + b^2}}$ and $\frac{1 + \sqrt{2}}{\sqrt{1 + b^2}}$

union of sets over all b is square.

Example 18 (Damped pendulum). Here $\begin{pmatrix} \dot{x} \\ \dot{y} \end{pmatrix} = \begin{pmatrix} y \\ -ky - \sin x \end{pmatrix}$ with $k > 0$. We can choose $\mathcal{V} = \frac{1}{2}y^2 + 1 - \cos x$; clearly \mathcal{V} is positive definite provided we identify x and $x + 2\pi$, and $\dot{\mathcal{V}} = -ky^2 \leq 0$. So certainly the origin is Lyapunov stable by [L1]. But we cannot use [L2] since $\dot{\mathcal{V}}$ is not negative definite. Nonetheless from La Salle's principle we see that the set M_c is contained in the set of complete orbits satisfying $y = 0$. The only such orbits are $(0, 0)$ ($c = 0$) and $(\pi, 0)$ ($c = 2$) So these points are the only possible members of $\omega(\mathbf{x})$. Since the origin is Lyapunov stable we conclude that for all points \mathbf{x} s.t. $\mathcal{V} < 2$ the only member of $\omega(\mathbf{x})$ is the origin and so this point is asymptotically stable.

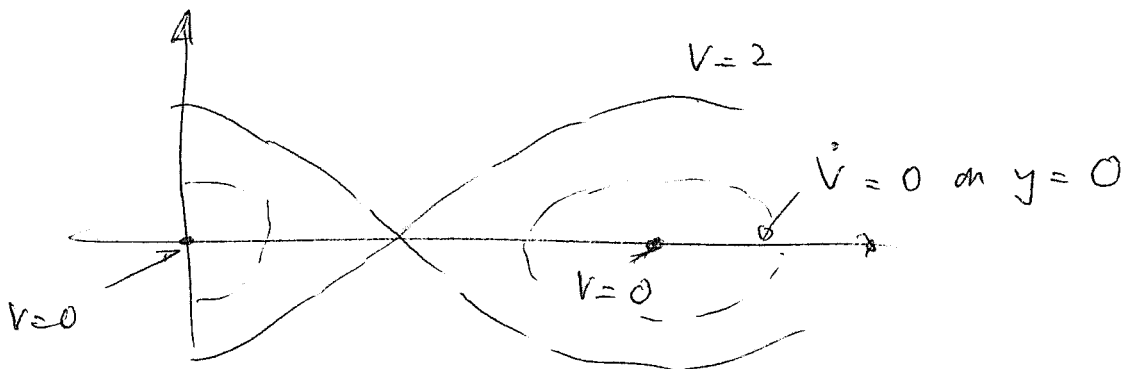

Special cases are *gradient flows*.

Definition 21 A system is called a **gradient system** or **gradient flow** if we can write $\dot{x} = -\nabla V(x)$.

In this case we have $\dot{V} = -|\nabla V|^2 \leq 0$, with $\dot{V} < 0$ except at the fixed points which have $|\nabla V| = 0$. Thus we can use La Salle's principle to show that $\Omega = \{\omega(x) : x \in E\}$ consists only of the fixed points. Note that this does NOT mean that all the fixed points are asymptotically stable (see diagram). These ideas can be extended to more general systems of the form $\dot{x} = -h\nabla V$, where $h(x)$ is a strictly positive continuously differentiable function. [Proof: exercise].

always point 'downhill'

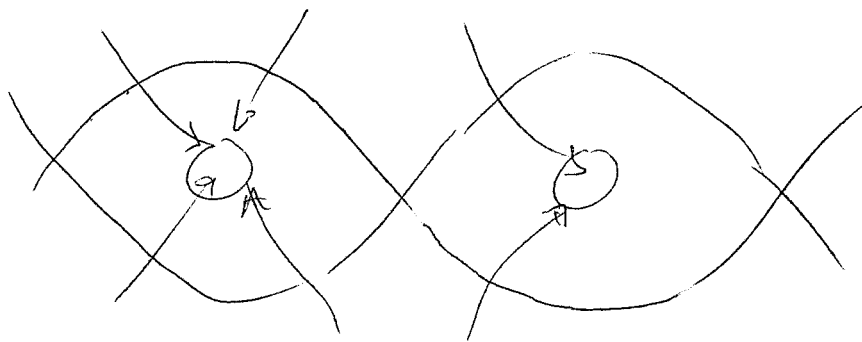

dynamics is that of strongly damped particle in potential

(not standard problem of undamped particle)

3.3 Bounding functions

Even when we cannot find a Lyapunov function in the exact sense, we can sometimes find positive definite functions \mathcal{V} s.t. $\dot{\mathcal{V}} < 0$ outside some neighbourhood of the origin. We call these **bounding functions**. They are used to show that x remains in some neighbourhood of the origin.

Theorem 8 Let $\mathcal{V} : E \subseteq \mathbb{R}^n \rightarrow \mathbb{R}$ be a continuously differentiable function, such that for each $k > 0$, $V_k = \{x \in E : \mathcal{V}(x) < k\}$ is a simply connected bounded domain with $V_k \subset V_{k'}$ if $k < k'$. Then if there is a simply connected compact domain $D \subset E$ such that, for all $x \notin D$, $\dot{\mathcal{V}}(x) < -\delta < 0$ for some $\delta > 0$, and there is a $\kappa > 0$ such that $D \subset V_\kappa$ then all orbits eventually enter and remain inside the set V_κ .

Proof: exercise (see diagram).

$$k_1 > k_2 > k_3$$

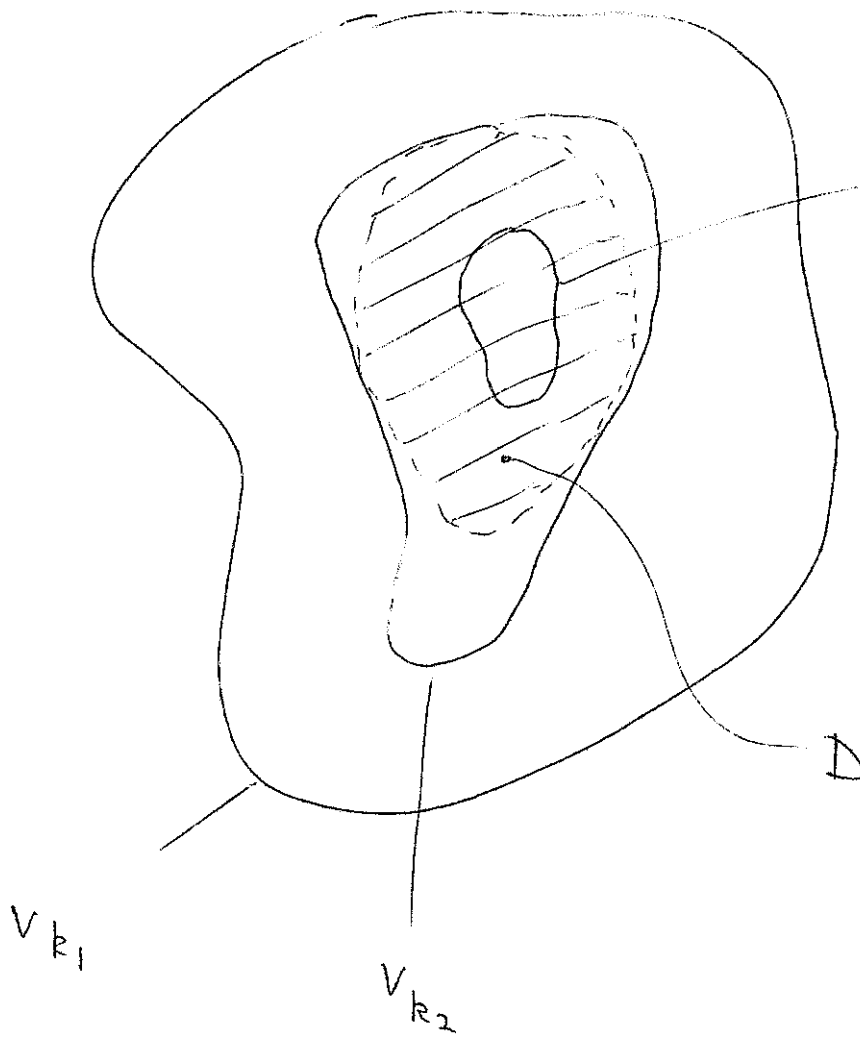

$$\dot{V} < 0 \text{ for } \underline{x} \notin D$$

all trajectories enter and remain in V_{k_2}

$$k = k_2 = \sup(V(x); \underline{x} \in D)$$

4 Existence and stability of periodic orbits in \mathbb{R}^2

Example 19 *Damped pendulum with torque.* Consider the system $\ddot{\theta} + k\dot{\theta} + \sin\theta = F$, $k > 0$, $F > 0$. We would like to know whether there is a periodic orbit of this equation. We can find a bounding function of the form $\mathcal{V} = \frac{1}{2}p^2 + 1 - \cos\theta$ ($p = \dot{\theta}$). Then $\dot{\mathcal{V}} = p\dot{p} + \dot{\theta}\sin\theta = p(F - kp)$. Thus $\dot{\mathcal{V}} < 0$ unless $0 < p < F/k$. Maximum value of \mathcal{V} on boundary of this domain is $\mathcal{V}_{max} = \frac{1}{2}(\frac{F}{k})^2 + 2$. By previous result on bounding functions we see that all orbits eventually enter and remain in the region $\mathcal{V} < \mathcal{V}_{max}$.

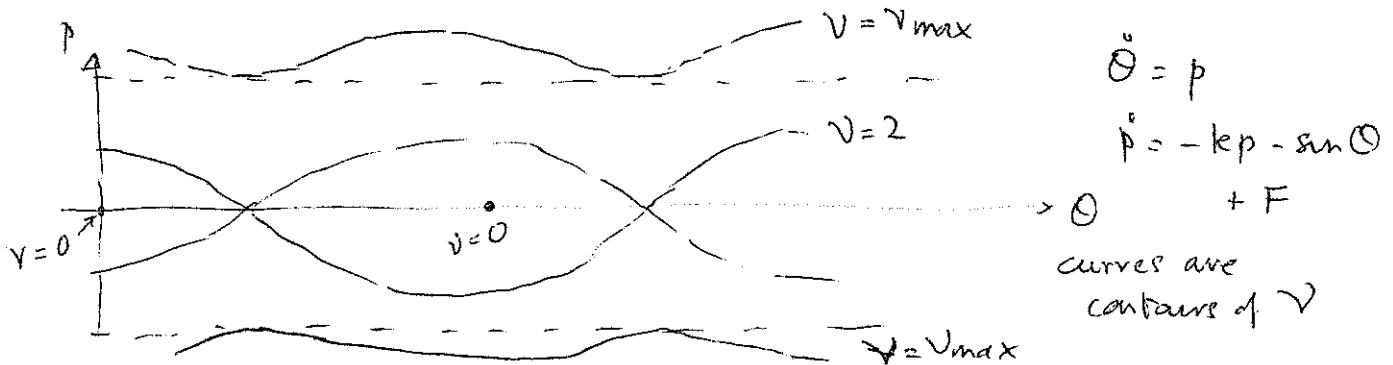

What happens within this region? We can look for fixed points: these are at $p = 0$, $\sin\theta = F$. So there are 2 f.p.'s if $F < 1$, no f.p.'s if $F > 1$. In the first case one fixed point is stable (node or focus depending on k) and the other is a saddle. In the second case what can happen? Either there is a closed orbit or possibly a space filling curve. There are some nontrivial theorems that we can use to answer this.

4.1 The Poincaré Index

Closed curves can be distinguished by the number of rotations of the vector field \mathbf{f} as the curve is traversed. This property of a curve in a vector field is very useful in understanding the phase portrait.

Definition 22 (*Poincaré Index*). Consider a vector field $\mathbf{f} = (f_1, f_2)$. At any point the direction of \mathbf{f} is given by $\psi = \tan^{-1}(f_2/f_1)$ (with the usual conventions). Now let \mathbf{x} traverse a closed curve C . ψ will increase by some multiple (possibly negative) or 2π . This multiple is called the **Poincaré Index** I_C of C .

This index can be put in integral form. We have

$$I_C = \frac{1}{2\pi} \oint_C d\psi = \frac{1}{2\pi} \oint_C d \tan^{-1} \left(\frac{f_2}{f_1} \right) = \frac{1}{2\pi} \oint_C \frac{f_1 df_2 - f_2 df_1}{f_1^2 + f_2^2}$$

In fact the index is most easily worked out by hand. There are several results that are easily proved about Poincaré indices that makes them easier to calculate.

1. **The index takes only integer values, and is continuous when the vector field has no zeroes.** It therefore is the same for two curves which can be deformed into each other without crossing any fixed point.

2. The index of any curve not enclosing any fixed point is zero. This is because it can be shrunk to zero size.
3. The index of a curve enclosing a number of fixed points is the sum of the indices for curves enclosing the fixed points individually. This is because the curve can be deformed into small curves surrounding each fixed point together with connecting lines along which the integral cancels.

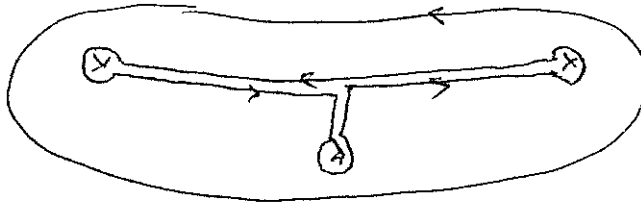

4. The index of a curve for $\dot{x} = f(x)$ is the same as that of the system $\dot{x} = -f(x)$. Proof: Consider effect on integral representation of the change $f \rightarrow -f$.
5. The index of a periodic orbit is +1. The vector field is tangent to the orbit at every point.

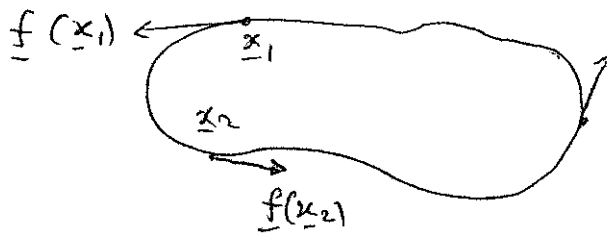

6. The index of a saddle is -1, and of a node or focus +1. By inspection, or by noting that in complex notation a saddle can be written, in suitable coordinates as $\dot{x} = x, \dot{y} = -y$ or $\dot{z} = \bar{z}$. For a node or focus, curve can be found such that trajectories cross in same direction.

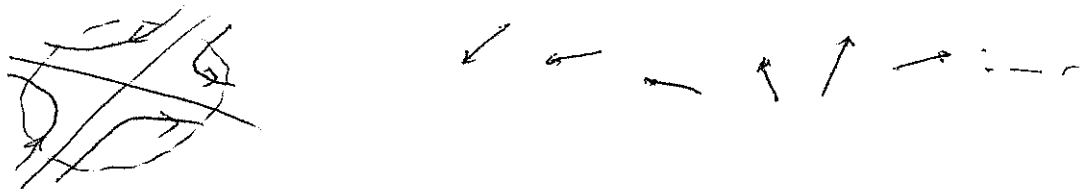

7. Indices of more complicated, non hyperbolic points can be found by adding the indices for the simpler fixed points that may appear under perturbation. This is because a small change in the system does not change the index round a curve where the vector field is smooth. e.g. index of a saddle-node $\dot{x} = x^2, \dot{y} = -y$ is zero, since indices of saddle and node cancel.

The most important result that follows from the above is that any periodic orbit contains at least one fixed point. In fact the total number of nodes and foci enclosed by a periodic orbit must exceed the total number of saddles enclosed by the orbit by one. Proof: simple exercise.

4.2 Poincaré-Bendixson Theorem

This remarkable result, which only holds in \mathbb{R}^2 , is very useful for proving the existence of periodic orbits.

Theorem 9 (Poincaré-Bendixson). Consider the system $\dot{\mathbf{x}} = \mathbf{f}(\mathbf{x})$, $\mathbf{x} \in \mathbb{R}^2$, and suppose that \mathbf{f} is continuously differentiable. If the forward orbit $\mathcal{O}^+(\mathbf{x})$ remains in a compact (closed and bounded) set D (i.e. once the orbit enters D then it stays in D) containing no fixed points then $\omega(\mathbf{x})$ contains a periodic orbit.

We can apply this directly to the pendulum equation with $F > 1$ to show that there is at least one (stable) periodic orbit. However we cannot rule out multiple periodic orbits.

The proof of the Poincaré-Bendixson Theorem is quite complicated. Before starting it is useful to establish a preliminary result concerning multiple intersections of a trajectory with a transversal. A transversal is a line or curve (typically not closed) that trajectories cross from one side to the other. A transversal can be defined in a neighbourhood of any point that is not a fixed point. (See diagram.)

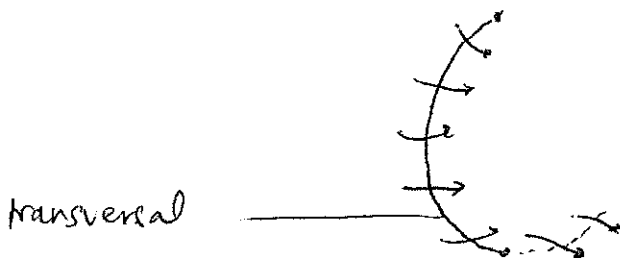

In \mathbb{R}^2 transversals have the important property that, if a trajectory has multiple intersections with the transversal, then successive intersections move monotonically along the transversal. (See diagram.) Note that this property has no counterpart in higher dimensions.

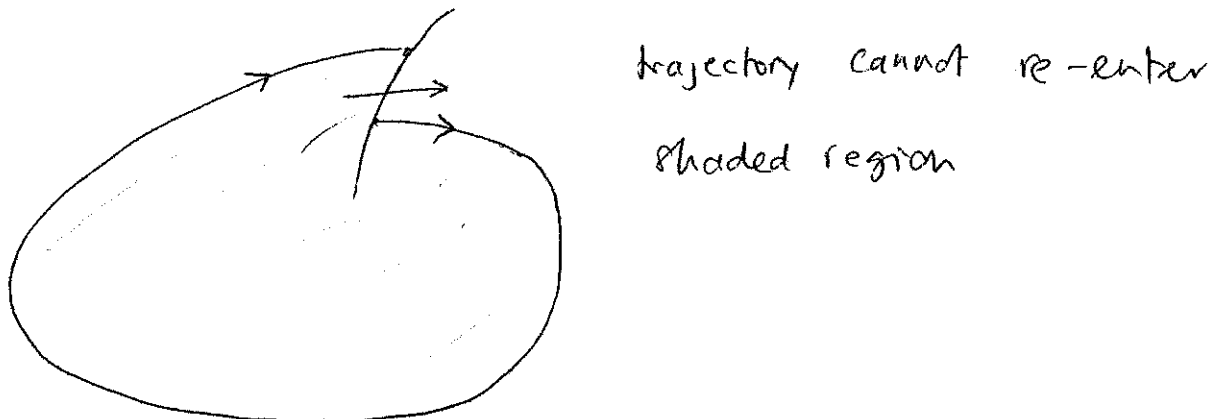

Proof of the Poincaré-Bendixson Theorem: We first note that since $\mathcal{O}^+(\mathbf{x})$ remains in a compact set D , then $\omega(\mathbf{x})$ is non-empty, with $\omega(\mathbf{x}) \subset D$.

Choose $\mathbf{y} \in \omega(\mathbf{x})$ and then $\mathbf{z} \in \omega(\mathbf{y})$. Note that $\mathbf{y} \in D$ and hence $\mathbf{z} \in D$ and that neither are fixed points (by assumption). We show first that $\mathcal{O}^+(\mathbf{y})$ is a periodic orbit. Pick a local transversal Σ through \mathbf{z} , then $\mathcal{O}^+(\mathbf{y})$ makes intersections with Σ arbitrarily close to \mathbf{z} . [Choose a set of points on $\mathcal{O}^+(\mathbf{y})$ that come arbitrarily close to \mathbf{z} . Given continuity of $\mathbf{f}(\mathbf{x})$ in the neighbourhood of \mathbf{z} the trajectory through each point must have a nearby intersection with Σ .]

If $\mathcal{O}^+(\mathbf{y})$ intersects Σ at \mathbf{z} then $\mathcal{O}^+(\mathbf{y})$ is closed. [$\mathbf{z} \in \mathcal{O}^+(\mathbf{y})$, if next intersection of $\mathcal{O}^+(\mathbf{y})$ is not at \mathbf{z} then successive intersections must move away from \mathbf{z} by the monotonicity property. This is inconsistent with $\mathbf{z} \in \omega(\mathbf{y})$.]

If $\mathcal{O}^+(\mathbf{y})$ does not intersect Σ at \mathbf{z} then suppose one intersection is at \mathbf{y}_1 and the next is at \mathbf{y}_2 . But $\mathbf{y}_1 \in \omega(\mathbf{x})$ and $\mathbf{y}_2 \in \omega(\mathbf{x})$, implying that there is an intersection of $\mathcal{O}^+(\mathbf{x})$ with Σ that is arbitrarily close to \mathbf{y}_1 , a later intersection that is arbitrarily close to \mathbf{y}_2 and later to that, an intersection that is arbitrarily close to \mathbf{y}_1 . But this is inconsistent with the monotonicity property, so $\mathbf{y}_1 = \mathbf{y}_2$ and $\mathcal{O}^+(\mathbf{y})$ is closed.

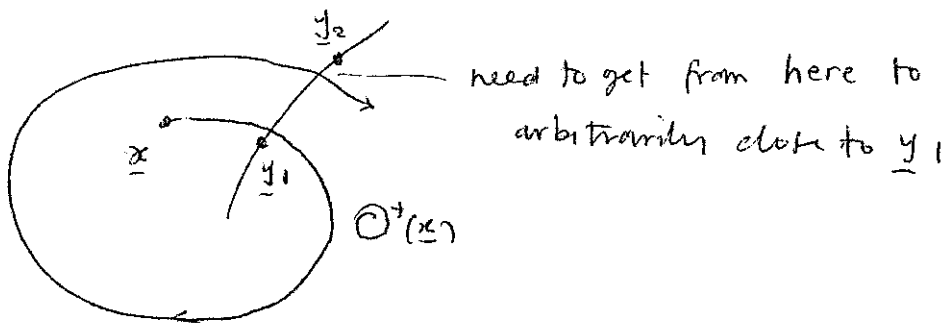

Furthermore $\mathbf{z} = \mathbf{y}_1 = \mathbf{y}_2$, otherwise \mathbf{z} cannot be in $\omega(\mathbf{y})$. So $\mathbf{z} \in \mathcal{O}^+(\mathbf{y})$ and hence $\mathbf{z} \in \omega(\mathbf{x})$ (because the latter is invariant). Hence $\mathcal{O}^+(\mathbf{y}) \subset \omega(\mathbf{x})$. In fact $\mathcal{O}^+(\mathbf{y}) = \omega(\mathbf{x})$, since if $\hat{\mathbf{y}} \notin \mathcal{O}^+(\mathbf{y})$ then it cannot be the case that there is an infinite sequence of points in $\mathcal{O}^+(\mathbf{x})$ that come arbitrarily close to $\hat{\mathbf{y}}$. (But note also that $\omega(\mathbf{x})$ may be different for different \mathbf{x} .)

Example 20 Consider the system

$$\begin{pmatrix} \dot{x} \\ \dot{y} \end{pmatrix} = \begin{pmatrix} x - y + 2x^2 + axy - x(x^2 + y^2) \\ y + x + 2xy - ax^2 - y(x^2 + y^2) \end{pmatrix}. \text{ In polar coordinates we get}$$

$\dot{r} = r + 2r^2 \cos \theta - r^3, \dot{\theta} = 1 - a \cos \theta$. Then $\dot{r} > 0$ for $r < \sqrt{2} - 1$, and $\dot{r} < 0$ for $r > \sqrt{2} + 1$. Thus the trajectories enter the annulus $\sqrt{2} - 1 \leq r \leq \sqrt{2} + 1$. For any fixed points we have $1 + 2r \cos \theta - r^2 = 0, 1 - a \cos \theta = 0$. Hence $x = 1/a, r^2 = 1 + 2/a$. So there are fixed points in the annulus only if $\sqrt{2} - 1 < \sqrt{1 + 2/a} < \sqrt{2} + 1$. The first inequality is always satisfied, the second requires $1/a < 1 + \sqrt{2}$, i.e. $a > \sqrt{2} - 1$. Thus if $a < \sqrt{2} - 1$ then there must be a periodic orbit in the annulus.

4.3 Dulac's criterion and the divergence test

Suppose that $\dot{\mathbf{x}} = \mathbf{f}(\mathbf{x})$ has a periodic orbit \mathcal{C} . Then \mathbf{f} is tangent to \mathcal{C} at every point and since there are no fixed points on \mathcal{C} we have that $\rho(\mathbf{x})\mathbf{f}(\mathbf{x}) \cdot \mathbf{n} = 0$ everywhere on \mathcal{C} , where ρ is a C^1 function and \mathbf{n} is the unit outward normal. Then

$$\oint_{\mathcal{C}} \rho \mathbf{f} \cdot \mathbf{n} d\ell = \int_A \nabla \cdot (\rho \mathbf{f}) dA = 0$$

Thus unless ρ and \mathbf{f} are such that $\nabla \cdot (\rho \mathbf{f})$ takes different signs within the periodic orbit, we have a contradiction. This is a special case of

Theorem 10 (*Dulac's negative criterion*). Consider a dynamical system $\dot{\mathbf{x}} = \mathbf{f}$, $\mathbf{x} \in \mathbb{R}^n$. If there is a C^1 scalar function $\rho(\mathbf{x})$, such that $\nabla \cdot (\rho \mathbf{f}) < 0$ everywhere (or > 0 everywhere) in some domain $E \subseteq \mathbb{R}^n$, then there are no invariant sets of dimension $n-1$ wholly within E and enclosing finite volume.

Proof: suppose there is such a set S enclosing a volume $V \subset E$. Then since S is invariant $\rho(\mathbf{x})\mathbf{f}(\mathbf{x}) \cdot \mathbf{n} = 0$, where \mathbf{n} is the outward normal to S . But

$$\int_S \rho \mathbf{f} \cdot \mathbf{n} d\ell = 0 = \int_V \nabla \cdot (\rho \mathbf{f}) dV.$$

But $\nabla \cdot (\rho \mathbf{f})$ is one-signed by assumption and so the integral on the right-hand side cannot be zero.

Often it is only necessary to take $\rho = 1$. If conditions of the theorem satisfied in \mathbb{R}^2 then there are no periodic orbits in E , if in \mathbb{R}^3 there are no invariant 2-tori, etc.

Example 21 (*Lorenz system*). Here we are in \mathbb{R}^3 and equations are

$$\begin{pmatrix} \dot{x} \\ \dot{y} \\ \dot{z} \end{pmatrix} = \begin{pmatrix} \sigma y - \sigma x \\ rx - y - zx \\ -bz + xy \end{pmatrix}.$$

Hence $\nabla \cdot \mathbf{f} = -\sigma - 1 - b < 0$. Thus this system has no invariant sets of dimension 2 that enclose non-zero volume. Note that periodic orbits, which are not of dimension 2 and do not enclose a volume, are not excluded.

Example 22 Return to Example 19 (damped pendulum with torque) and consider the phase space $-\infty < p < \infty$, $0 \leq \theta < 2\pi$ to be the surface of a cylinder. We have seen that when $F > 1$ there are no fixed points and so, by Poincaré-Bendixson, there must be a periodic orbit in the region $\mathcal{V} < \mathcal{V}_{\max}$. However $\nabla \cdot \mathbf{f} = -k < 0$ and so, by Dulac's criterion, there are no periodic orbits **not** encircling the cylinder. Orbits that do encircle the cylinder (orbits of 'rotational' type) are not ruled out, since they have no 'interior' and so the theorem does not apply. But now suppose there are two periodic orbits (both necessarily encircling the cylinder). Consider the integral of $\nabla \cdot \mathbf{f}$ over the region between the two orbits (in an extension of the standard form of Dulac's criterion) to obtain a contradiction. Thus there is a unique periodic orbit, of rotational type, when $F > 1$. Since it is unique and trajectories enter the region $\mathcal{V} < \mathcal{V}_{\max}$ it must be stable.

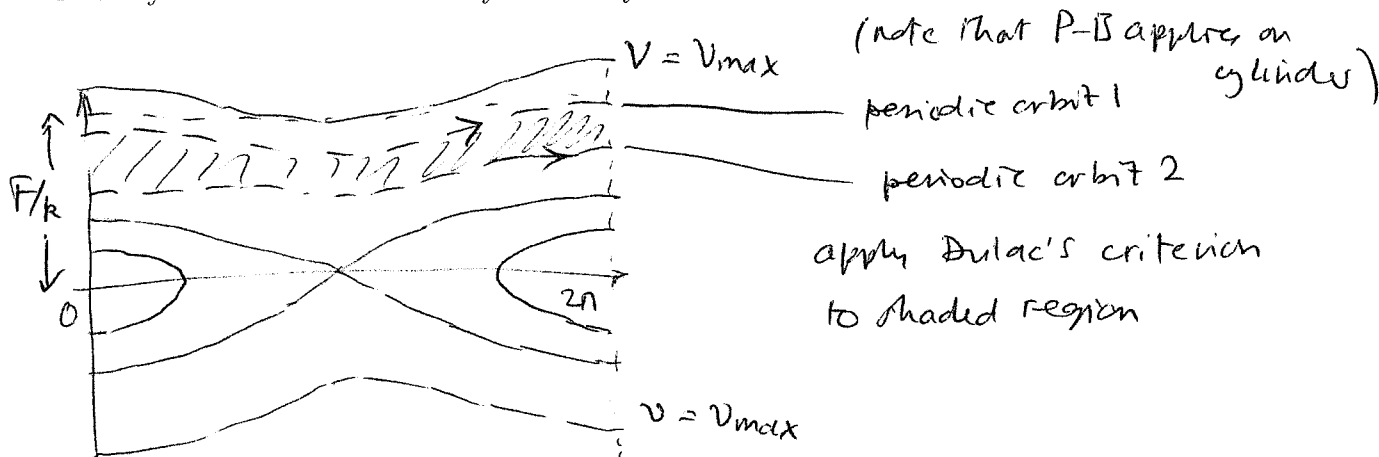

Example 23 (Predator-Prey equations). These take the general form

$$\begin{pmatrix} \dot{x} \\ \dot{y} \end{pmatrix} = \begin{pmatrix} x(A - a_1x + b_1y) \\ y(B - a_2y + b_2x) \end{pmatrix}, \text{ where } a_1, a_2 \geq 0. \text{ The lines } x = 0, y = 0 \text{ are invariant.}$$

Are there periodic orbits in the first quadrant? Consider $\rho = (xy)^{-1}$. Then $\nabla \cdot \rho \mathbf{f} = \frac{\partial}{\partial x}(y^{-1}(A - a_1x + b_1y)) + \frac{\partial}{\partial y}(x^{-1}(B - a_2y + b_2x)) = -a_1y^{-1} - a_2x^{-1} < 0$. So there are no periodic orbits unless $a_1 = a_2 = 0$. In this case we potentially have an infinite number of periodic orbits, which are contours of $U(x, y) = A \ln y - B \ln x + b_1y - b_2x$, provided these are closed curves. [When is this true?]

Another useful result excluding periodic orbits relies on the fact that on such orbits the vector field \mathbf{f} is everywhere tangent to the orbit and is never zero.

Theorem 11 (Gradient criterion). Consider a dynamical system $\dot{\mathbf{x}} = \mathbf{f}$ where \mathbf{f} is defined throughout a simply connected domain $E \subset \mathbb{R}^2$. If there exists a positive function $\rho(\mathbf{x})$ such that $\rho \mathbf{f} = \nabla \psi$ for some single valued function ψ , then there are no periodic orbits lying entirely within E .

Proof: if $\rho \mathbf{f} = \nabla \psi$ then for a periodic orbit \mathcal{C} , $\oint_{\mathcal{C}} \rho \mathbf{f} \cdot d\ell = \oint_{\mathcal{C}} \nabla \psi \cdot d\ell = 0$. But this is impossible as $\rho \mathbf{f} \cdot d\ell$ has the same sign everywhere on \mathcal{C} .

Example 24 Consider the system $\begin{pmatrix} \dot{x} \\ \dot{y} \end{pmatrix} = \begin{pmatrix} 2x + xy^2 - y^3 \\ -2y - xy^2 + x^3 \end{pmatrix}$. Hard to apply Dulac. But in fact $e^{xy} \mathbf{f} = \nabla(e^{xy}(x^2 - y^2))$ and so there are no periodic orbits.

4.4 Near-Hamiltonian flows

Many systems of importance have a Hamiltonian structure; that is they may be written in the form

$$\begin{pmatrix} \dot{x} \\ \dot{y} \end{pmatrix} = \begin{pmatrix} H_y \\ -H_x \end{pmatrix}$$

Then it is easy to see that $\frac{dH}{dt} = \dot{x}H_x + \dot{y}H_y = 0$ so that the curves $H = \text{const.}$ are invariant. If these curves are closed then they are periodic orbits, but not limit cycles since they are not isolated. The Jacobian of \mathbf{f} at the fixed point is $\begin{pmatrix} H_{xy} & H_{yy} \\ -H_{xx} & -H_{xy} \end{pmatrix}$.

Thus the trace is always zero and fixed points are either saddles or (nonlinear) centres.

Example 25 Consider $\ddot{x} + x - x^2$. Writing $y = \dot{x}$, we have an equation in Hamiltonian form, with $H = \frac{1}{2}(y^2 + x^2) - \frac{1}{3}x^3$. There are two fixed points, at $y = 0, x = 0, 1$, which are a centre and a saddle respectively. Using symmetry about the x -axis we can construct the phase portrait.

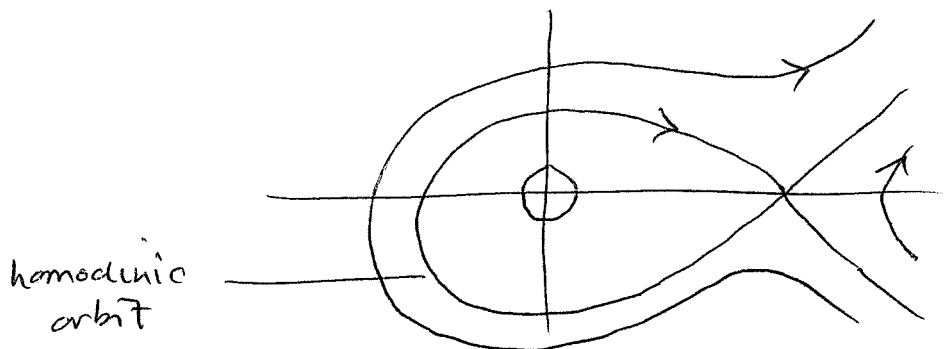

Writing a system in Hamiltonian form with perturbations is a useful approach to finding conditions for periodic orbits. Suppose we have the system

$$\begin{pmatrix} \dot{x} \\ \dot{y} \end{pmatrix} = \begin{pmatrix} H_y + g_1(x, y) \\ -H_x + g_2(x, y) \end{pmatrix} \tag{2}$$

then we can see that

$$\frac{dH}{dt} = g_2\dot{x} - g_1\dot{y} = (g_2 - \dot{y})\dot{x} + (\dot{x} - g_1)\dot{y} \tag{3}$$

If there is a closed orbit C , we have from the above that $\oint_C dH = \oint_C g_2 dx - g_1 dy = 0$. If we can show that this line integral cannot vanish, we can deduce that there are no periodic orbits.

Example 26 Consider $\begin{pmatrix} \dot{x} \\ \dot{y} \end{pmatrix} = \begin{pmatrix} y \\ -x + x^2 + \epsilon y(a - x) \end{pmatrix}$ ($\epsilon > 0$). Choose the same H as in the previous example 25; then for a periodic orbit C we must have $\oint_C y^2(a - x) dt = 0$. We can see from the equation that the extrema of x are reached when $y = 0$, and that the fixed points of the system are still at $(0, 0)$ (focus/node) and $(1, 0)$ (saddle) (Exercise: verify this). The index results show that no periodic orbit can enclose both fixed points, so the maximum value of x on a periodic orbit is 1. Thus if $a > 1$ there are no periodic orbits (however small ϵ). (Note that $\dot{x} = y$ implies that if $x > 1$ somewhere on an orbit then $(1, 0)$ must be enclosed by that orbit.)

If the flow is *nearly Hamiltonian*, and the value of H is such that the Hamiltonian orbit is closed, we can derive an approximate relation for the rate of change of H . From equation (3) we have exactly $dH/dt = g_2\dot{x} - g_1\dot{y}$. If g_1, g_2 are very small, then H changes very slowly and trajectories are almost closed. If we average over a period of the Hamiltonian flow, then the effect of fluctuations in the r.h.s. around the (almost-closed) orbit are averaged out and we deduce an equation for the slow variation of H :

$$\frac{dH}{dt} \approx \mathcal{F}(H) = \langle g_2\dot{x} - g_1\dot{y} \rangle = \Delta H/P(H) \tag{4}$$

where the brackets denote the average over a period of the Hamiltonian flow, with the quantities to be averaged evaluated for the Hamiltonian flow itself. ΔH is the predicted

(small) change in H over one period and $P(H)$ is the period of an orbit in the Hamiltonian flow as a function of the value that the Hamiltonian takes on that orbit. (The error in assuming that the $g_i = 0$ when calculating \dot{x} as a function of x (and H) leads to errors of order $|g_i|^2$.) If the reduced system described by this equation has a fixed point this corresponds to a periodic orbit of the nearly-Hamiltonian flow. It has no fixed points then the nearly-Hamiltonian flow has no periodic orbits. This method is known as the *energy balance* or *Melnikov method* though the latter term is usually used for the application of the method to non-autonomous perturbations to Hamiltonian flows.

Example 27 Consider the same example as above but now with $\epsilon \ll 1$. Then for the Hamiltonian flow (with $\epsilon = 0$) we have orbits described by $y = \pm\sqrt{2H - x^2 + \frac{2}{3}x^3}$ (with H here corresponding to the value of the Hamiltonian function a particular orbit). The equation (4) for the slow variation of H is then

$$\frac{dH}{dt} = \frac{\Delta H}{P(H)} = \frac{\epsilon}{P(H)} \oint (a - x)y^2 dt = \frac{2\epsilon \int_{x_{\min}}^{x_{\max}} (a - x)(2H - x^2 + \frac{2}{3}x^3)^{\frac{1}{2}} dx}{2 \int_{x_{\min}}^{x_{\max}} (2H - x^2 + \frac{2}{3}x^3)^{-\frac{1}{2}} dx},$$

where x_{\min}, x_{\max} are the extrema of x on the orbit. The denominator of the r.h.s. of this equation is an explicit expression for $P(H)$. The integrals are written in terms of x by noting that, for this system, $ydt = dx$. Setting the l.h.s.=0 gives the possible values of H , for a specified value of a , for which the perturbed system has a periodic orbit. The integrals in general cannot be done exactly, except for the special case where $H = 1/6$, for which the corresponding orbit of the unperturbed Hamiltonian system is the homoclinic orbit passing through $(1,0)$. The corresponding value of dH/dt is < 0 for $a < 1/7$ and > 0 for $a > 1/7$. For H small, i.e. for a small closed orbit around the fixed point at $(0,0)$, it is clear that dH/dt has the same sign as a . These results suggest that there is no stable periodic orbit for $a < 0$ (trajectories spiral slowly into the origin), that for $0 < a < 1/7$ there is a stable periodic orbit and that for $a > 1/7$ there is no periodic orbit (trajectories move slowly outward to the fixed point on the homoclinic orbit) and then rapidly outward along an unbounded trajectory of the unperturbed system. (We see from this that the lower limit $a = 1$, deduced earlier, for the existence of periodic orbits the bound $a = 1$ is not a very good estimate at least at small ϵ !)

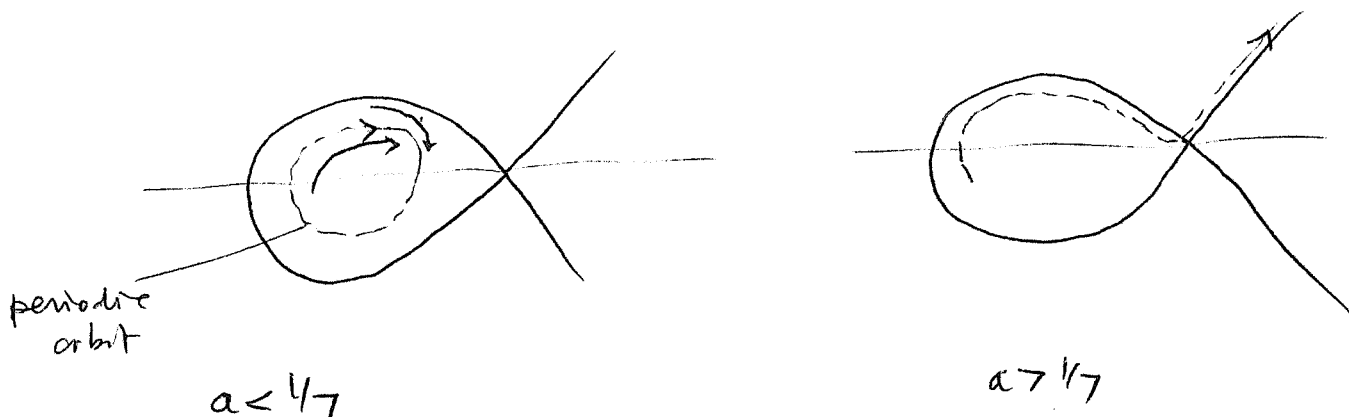

(e.g. in matlab demo take $\epsilon = 0.2$ and contrast $a = 0.1$ and $a = 0.2$)

4.5 Stability of Periodic Orbits

4.5.1 Floquet multipliers and Lyapunov exponents

While individual points on a periodic orbit are not fixed points and it therefore does not make sense to consider their stability, we can consider the stability of the whole orbit as an invariant set. We can develop a theory (**Floquet theory**) for determining whether an orbit is asymptotically stable to infinitesimal disturbances. Consider again $\dot{\mathbf{x}} = \mathbf{f}(\mathbf{x})$ (in \mathbb{R}^n) and suppose there is a periodic orbit $\mathbf{x} = \hat{\mathbf{x}}(t)$. Letting $\mathbf{x} = \hat{\mathbf{x}} + \boldsymbol{\xi}(t)$, and linearizing, we find

$$\dot{\boldsymbol{\xi}} = \mathbf{A}(t)\boldsymbol{\xi}, \quad \text{where } \mathbf{A} = D\mathbf{f}_{\mathbf{x}=\hat{\mathbf{x}}(t)}. \quad (5)$$

This is a linear ordinary differential equation with periodic coefficients, and there is much theory concerning it. We want to know what happens to an initial disturbance $\boldsymbol{\xi}(0)$ after one period P of the original orbit. Integrating equation (5) from $t = 0$ to $t = P$, we can exploit linearity to write the relation $\boldsymbol{\xi}(P) = \mathbf{F}\boldsymbol{\xi}(0)$, where \mathbf{F} is a matrix that depends only on $D\mathbf{f}$ on the orbit and not on $\boldsymbol{\xi}(0)$. The eigenvalues of this matrix are called **Floquet multipliers**. One of them is always unity for an autonomous system because equation (5) is always solved by $\boldsymbol{\xi}(t) = \mathbf{f}(\hat{\mathbf{x}}(t))$. (This represents a perturbation along the orbit.)

Another way to find the Floquet multipliers is via a map. We construct a local transversal subspace Σ through $\hat{\mathbf{x}}(0)$. Then all trajectories close enough to the periodic orbit intersect Σ in the same direction as the periodic orbit. Successive intersections of trajectories with Σ define a map (the **Poincaré [Return] Map** $\Phi : \Sigma \rightarrow \Sigma$). If \mathbf{z}_0 is the intersection of $\hat{\mathbf{x}}$ with Σ then $\Phi(\mathbf{z}_0) = \mathbf{z}_0$ so that \mathbf{z}_0 is a fixed point. Linearizing about this point we have $\Phi(\mathbf{z}) = \mathbf{z}_0 + (D\Phi)(\mathbf{z} - \mathbf{z}_0)$, where $D\Phi$ is an $(n-1) \times (n-1)$ matrix. Then the Floquet multipliers can be defined as the eigenvalues of $D\Phi$. This method suppresses the trivial unit eigenvalue described above. It is easy to prove that the choice of intersection with the periodic orbit does not affect the eigenvalues of $D\Phi$ [*Exercise*].

We can define the stability of the orbit to small perturbations in terms of the multipliers μ_i , $i = 1, 2, \dots, (n-1)$.

Definition 23 (*Hyperbolicity*). A periodic orbit is **hyperbolic** if none of the μ_i lie on the unit circle.

Then we have the theorem on stability analogous to that for fixed points:

Theorem 12

- (i) A periodic orbit $\hat{\mathbf{x}}(t)$ is asymptotically stable (a **sink**) if all the μ_i satisfy $|\mu_i| < 1$.
- (ii) If at least one of the μ_i has modulus greater than unity then the orbit is unstable (i.e. not Lyapunov stable).

Proof: very similar to that for fixed points: simple exercise.

Definition 24 (*Floquet exponents*). The **Floquet Exponents** λ_i of a periodic orbit are defined as $\lambda_i = P^{-1} \log |\mu_i|$, where the μ_i are the Floquet multipliers and P is the period. These are a measure of the rate of separation of nearby orbits. The term 'Lyapunov exponent' is sometimes used for this special case of periodic orbits, and is widely used for the extension to any type of trajectory, i.e. the Lyapunov exponent measures the rate of separation of nearby trajectories.

In \mathbb{R}^2 there is only one non-trivial μ , which must be real and positive. Recall the proof of Poincaré-Bendixson Theorem – the monotonicity property requires that a trajectory close to a periodic orbit either moves systematically towards it ($\mu < 1$) or systematically away from it ($\mu > 1$).

In this case we have $\mu = \exp\left(\int_0^P \nabla \cdot \mathbf{f}(\hat{\mathbf{x}}(t)) dt\right)$.

Proof: consider an infinitesimal rectangle of length δs and width $\delta \xi$ at $\hat{\mathbf{x}}(0)$, with the four corners of the rectangle following trajectories for $t > 0$. Then $A(0) = \delta \xi \delta s$. By standard result for conservation of area, $A = \int_{\partial A} \mathbf{f} \cdot \mathbf{n} dS \sim \nabla \cdot \mathbf{f} \times A$. Thus $\log(A(P)/A(0)) = \mu = \exp\left(\int_0^P \nabla \cdot \mathbf{f}(\hat{\mathbf{x}}(t)) dt\right)$, as required.

Remark: when we are in \mathbb{R}^n , $n \geq 3$ the μ_i may be complex; this leads to a wide variety of possible ways in which periodic orbits can lose stability:

- μ passes through +1. This is similar to bifurcations of fixed points (saddle-node, pitchfork etc). (See later.)
- μ passes through $e^{\pm 2ik\pi/n}$ (k, n coprime). This leads to a new orbit that has a period approximately n times the original. In particular when $n = 2$ we have twice the period.

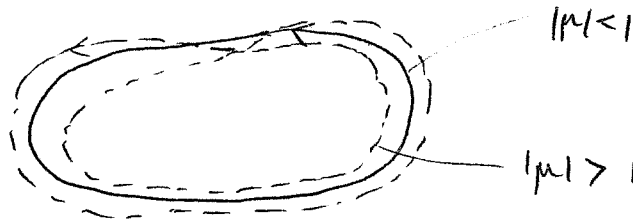

- μ passes through $e^{\pm 2i\nu\pi}$, ν irrational. the new solution is a 2-torus.

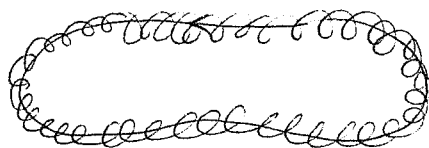

Example 28 (*Damped Pendulum with Torque*) Here we have $\nabla \cdot \mathbf{f} = -k$, and so $\mu < 1$ and the periodic orbit that we have already shown to exist is thus stable.

4.6 Example – the Van der Pol oscillator

This much studied equation can be derived from elementary electric circuit theory, incorporating a nonlinear resistance. It takes the form

$$\ddot{X} + (X^2 - \beta)\dot{X} + X = 0$$

which is the equation for a damped oscillator. If $\beta > 0$ then we have negative damping for small X , positive damping for large X . Thus we expect that oscillations grow to finite

amplitude and then stabilize. It is convenient to scale the equation by writing $X = \sqrt{\beta}x$, so that

$$\ddot{x} + \beta(x^2 - 1)\dot{x} + x = 0. \tag{6}$$

This equation is a special case of the **Liénard equation** $\ddot{x} + f(x)\dot{x} + g(x) = 0$. For analysis it is convenient to use the **Liénard Transformation**. We write $y = \dot{x} + F(x)$; $F(x) = \int_0^x f(s)ds$. Then in terms of x, y we have

$$\begin{pmatrix} \dot{x} \\ \dot{y} \end{pmatrix} = \begin{pmatrix} y - F(x) \\ -g(x) \end{pmatrix} \tag{7}$$

For the Van der Pol system, we have $g(x) = x$, $F(x) = \beta(\frac{1}{3}x^3 - x)$. If $\beta > 0$ then it is easily seen that the (only) fixed point, at the origin, is unstable. It is hard to apply Poincaré-Bendixson, however, since the distance from the origin does not decrease monotonically at large distances. However, we expect that there is a stable limit cycle. We can use qualitative methods to show this, but first we look at the cases of small and large β .

(a) $\beta \ll 1$. In this case the system is nearly Hamiltonian, with $H = \frac{1}{2}(x^2 + y^2)$, and $g_1 = -F(x)$, $g_2 = 0$. Hence the Hamiltonian flow is parametrized by $x = \sqrt{2H} \sin t$, $y = \sqrt{2H} \cos t$, and the period $P(H)$ is 2π . Thus the energy balance method yields

$$\Delta H = - \int_0^{2\pi} \dot{y}F(x)dt = \beta \int_0^{2\pi} (x^2 - \frac{x^4}{3})dt = \beta \int_0^{2\pi} (2H \sin^2 t - \frac{4H^2}{3} \sin^4 t)dt = 2\pi\beta(H - \frac{H^2}{2})$$

Clearly $\Delta H > 0$ if $H < 2$ and $\Delta H < 0$ if $H > 2$, so the equation (4) has a stable fixed point at $H = 2$, corresponding to a stable periodic orbit with $x \approx 2 \sin t$.

(b) $\beta \gg 1$. If x^2 is not close to unity then the damping term is very large, so we might expect $\dot{x} = O(\beta^{-1})$; in fact if we write $Y = y\beta^{-1}$ we get

$$\begin{pmatrix} \dot{x} \\ \dot{Y} \end{pmatrix} = \begin{pmatrix} \beta(Y - \frac{1}{3}x^3 + x) \\ -x\beta^{-1} \end{pmatrix}$$

so \dot{Y} is very small and Y varies only slowly. Either $|\dot{x}| \gg 1$ or else $Y \approx \frac{1}{3}x^3 - x$. Furthermore the latter, which defines a curve in the x, Y plane, is 'stable' only if the gradient of the curve is positive, i.e. only if $x^2 > 1$ in this particular case.

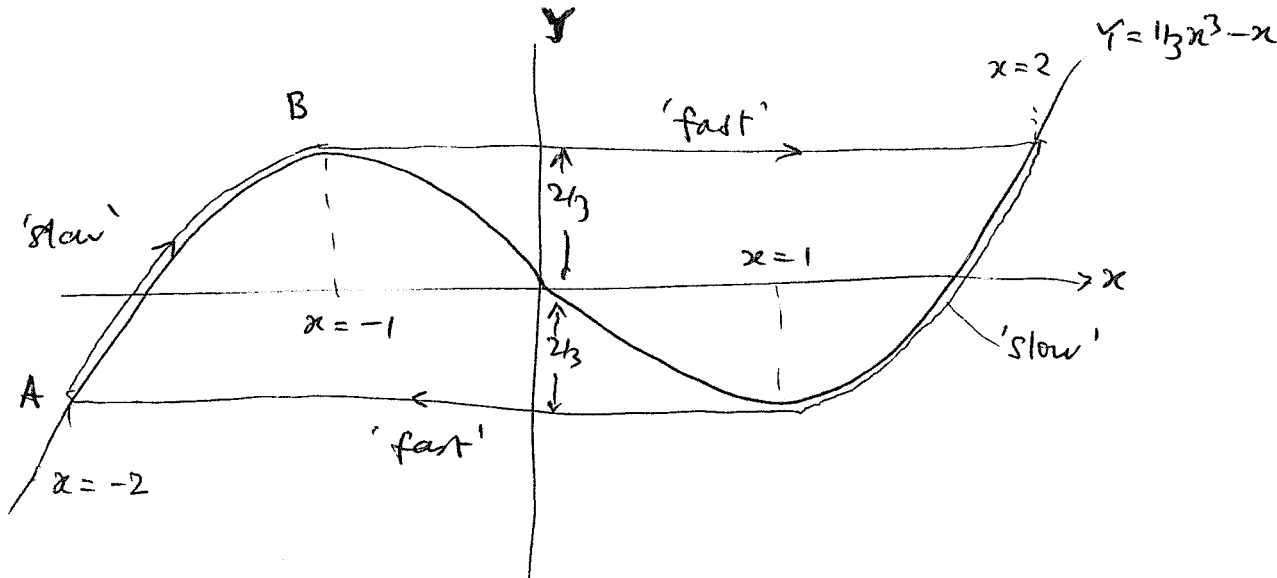

So the trajectory follows a branch of the curve $Y = \frac{1}{3}x^3 - x$ with positive gradient (the *slow manifold*) until it runs out, and then moves quickly (with $\dot{x} \gg \dot{Y}$) to another branch of the curve with positive gradient. The geometry of the curve allows a periodic orbit. Periodic behaviour of this kind is called a **relaxation oscillation**.

Assuming that there is such a periodic orbit (to be proved below) we can find an approximation to the period. Almost all the time is taken on the slow manifold, so the period P is given by

$$P = 2 \int_A^B dt = 2 \int_{-\frac{2}{3}}^{\frac{2}{3}} \frac{dY}{\dot{Y}} = 2 \int_{-\frac{2}{3}}^{\frac{2}{3}} -\frac{\beta}{x} dY = 2\beta \int_{-2}^{-1} \frac{(1-x^2)}{x} dx = \beta(3 - 2 \ln 2)$$

We now prove that there is a periodic orbit for all positive β . As a preliminary step note the general pattern of trajectories by considering the four regions of the plane bounded by the nullclines. These regions are (I): $x > 0, y > F(x)$, (II): $x > 0, y < F(x)$, (III) $x < 0, y < F(x)$ and (IV) $x < 0, y > F(x)$. If the trajectory starts in region I then x is increasing and y is decreasing. Thus trajectory must cross the curve $y = F(x)$ and enter region II. Now both x and y are decreasing, and \dot{y} decreases in magnitude as x decreases. Thus trajectory must cross into region III, where y is increasing and x is decreasing. Hence the trajectory enters region IV and, continuing the argument, eventually enters region I again.

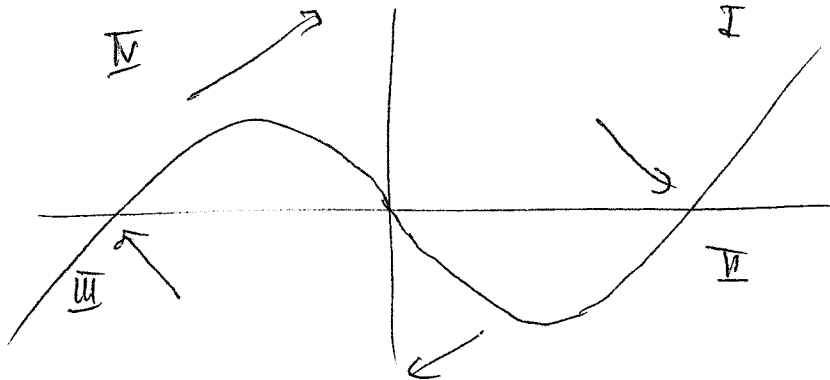

To construct a proof first consider the function $V_k(x, y) = \frac{1}{2}\{x^2 + (y - k)^2\}$.

$$\dot{V}_k = x(y - F(x)) - yx + kx = -xF(x) + kx = -\beta(\frac{1}{3}x^4 - x^2) + xk.$$

Note in particular that $\dot{V}_0 = -\beta(\frac{1}{3}x^4 - x^2)$ so that V_0 is increasing along trajectories for $|x| < \sqrt{3}$ and is decreasing for $|x| > \sqrt{3}$. We deduce that $\dot{V}_0 > 0$ if $V_0 < \frac{3}{2}$ and hence that trajectories starting in $x^2 + y^2 < 3$ eventually enter the region $x^2 + y^2 > 3$.

We now show that there is a region (containing $x^2 + y^2 < 3$) that trajectories cannot leave. See diagram below. ($x^2 + y^2 < 3$ is shown as a dotted circle.)

Consider a trajectory starting at $A (-x_0, y_0)$ with $x_0 > \sqrt{3} > 0$ and $y_0 > 0$. Choose y_0 sufficiently large that $y - F(x) > 0$ stays positive until the trajectory reaches $x = -\sqrt{3}$ at B . Note that $\dot{V} < 0$ for $-x_0 < x < -\sqrt{3}$, so B lies within the circle passing through A and centred at O . (The points B_2 and C_2 are marked as lying on this circle.) But $\dot{y} > 0$ for $-x_0 < x < -\sqrt{3}$, so B lies above $B_1 (\sqrt{3}, y_0)$.

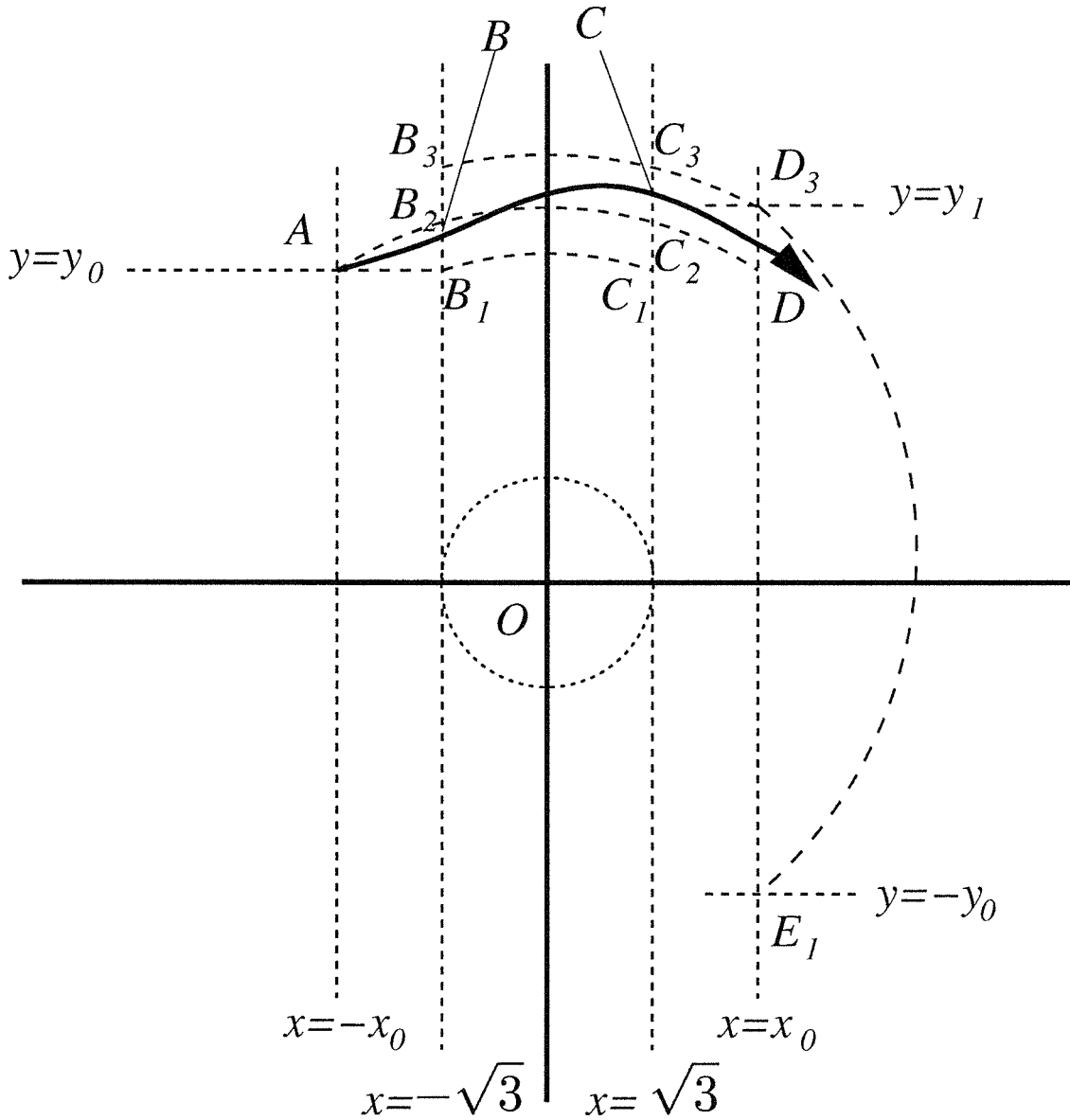

Now consider $-\sqrt{3} < x < \sqrt{3}$. $\dot{V}_0 > 0$ in this region, so the trajectory moves outward across circles centred on the origin. In particular the entire trajectory in this region lies outside the circular arc B_1C_1 . Hence $\dot{x} > y_0 - \frac{2}{3}\beta$ in this region. The change in V_0 along the trajectory from $x = -\sqrt{3}$ to $x = \sqrt{3}$ is given by

$$\Delta V_0 = \int_{x=-\sqrt{3}}^{x=\sqrt{3}} \beta(x^2 - \frac{1}{3}x^4) dt \leq \frac{1}{y_0 - \frac{2}{3}\beta} \int_{x=-\sqrt{3}}^{x=\sqrt{3}} \beta(x^2 - \frac{1}{3}x^4) dx = \frac{4\sqrt{3}\beta}{5(y_0 - \frac{2}{3}\beta)}.$$

Hence at $x = \sqrt{3}$ the trajectory lies within the circle centred on the origin with radius $(x_0^2 + y_0^2 + 8\sqrt{3}\beta / \{5(y_0 - \frac{2}{3}\beta)\})^{1/2}$, shown by the circular arc $B_3C_3D_3$. Hence the intersection l of the trajectory with $x = x_0$ lies below the point $D_3(x_0, y_1)$ where $y_1^2 = y_0^2 + 8\sqrt{3}\beta / \{5(y_0 - \frac{2}{3}\beta)\}$.

Now consider the circle centred on the y axis and passing through D_3 and $E_1 (x_0, -y_0)$. This circle is a contour of the function $V_k(x, y)$ where $k = \frac{1}{2}(y_1 - y_0)$. Using the previously derived expression $\dot{V}_k < 0$ in $x > 0$ provided that $\beta(\frac{1}{3}x_0^4 - x_0^2) > kx_0$. Since $k = \frac{1}{2}(y_1 - y_0) < 2\sqrt{3}\beta/\{5y_0(y_0 - \frac{2}{3}\beta)\}$, this condition is satisfied provided that $(\frac{1}{3}x_0^2 - 1)x_0 > 2\sqrt{3}\beta/\{5y_0(y_0 - \frac{2}{3}\beta)\}$, i.e. it becomes easier to satisfy as y_0 becomes larger.

From the above we deduce that there is a continuous curve defined by the trajectory $ABCD$, the line DD_3 (note that $\dot{x} > 0$ on this line) and the circle D_3E_1 that trajectories cannot cross from the 'inside'. Now complete this curve to a closed curve by reflecting about the origin. We deduce that no trajectories leave the enclosed region. It follows from Poincaré-Bendixon that there is at least one closed orbit in this enclosed region, with the orbit enclosing the region $x^2 + y^2 < 3$.

We can also prove that there is a unique closed orbit C_0 . Assume that there is a second closed orbit C_1 , shown with C_0 in the diagram below. In each case only half the orbit is shown, with the other half obtained by reflection in the origin.

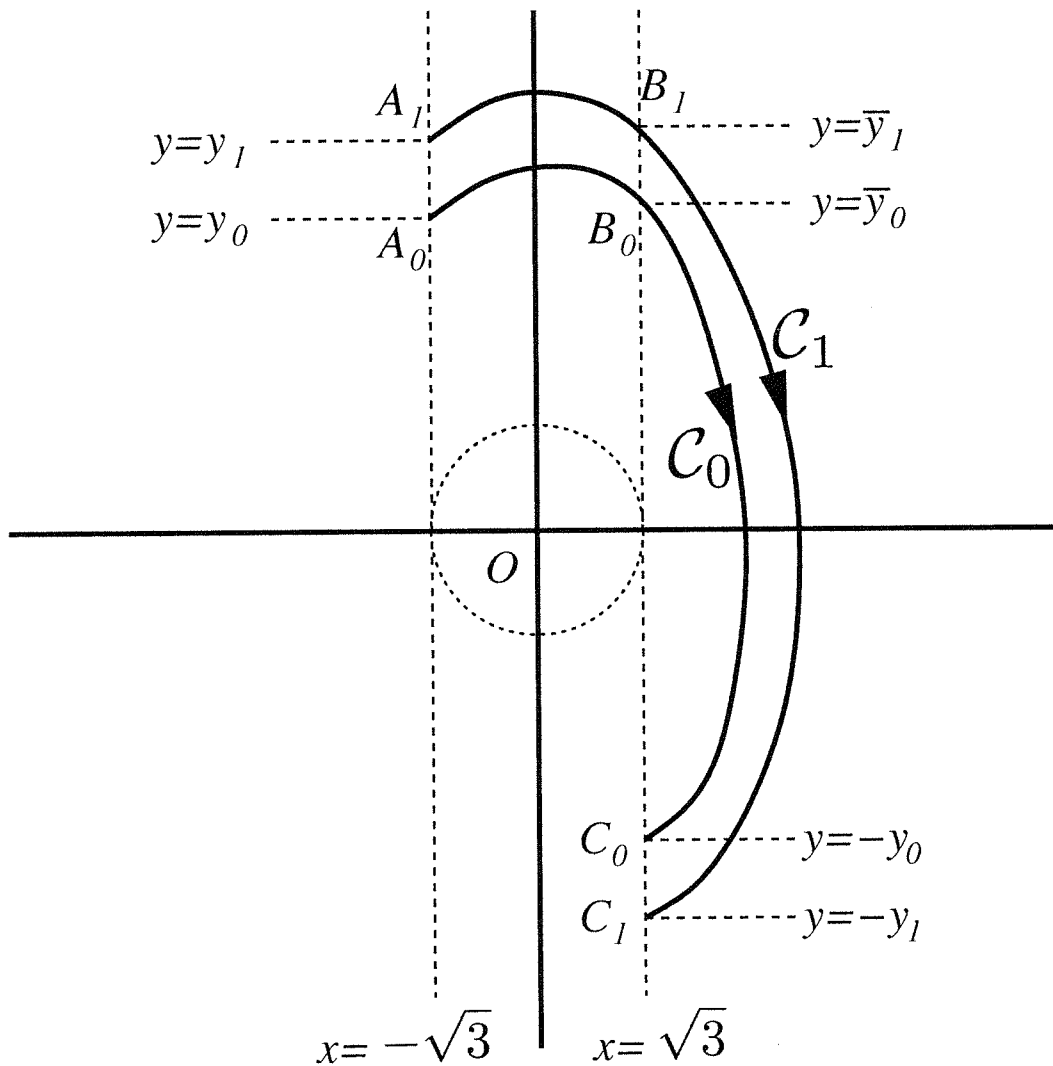

If \mathcal{C}_0 is closed then the value of the function $V_0(x, y)$ must be the same at A_0 as at C_0 . By previous results we have that V_0 increases on the section of orbit with $-\sqrt{3} < x < \sqrt{3}$ and decreases on the section with $x > \sqrt{3}$. Thus we have

$$V_0|_{B_0} - V_0|_{A_0} = V_0|_{B_0} - V_0|_{C_0} > 0.$$

Now consider the change in V_0 along the orbit \mathcal{C}_1 . For the part of the orbit A_1B_1

$$V_0|_{B_1} - V_0|_{A_1} = \int_{A_1}^{B_1} \dot{V}_0 dt = \int_{A_1}^{B_1} \dot{V}_0 \frac{dx}{y - F(x)} < \int_{A_0}^{B_0} \dot{V}_0 \frac{dx}{y - F(x)} = V_0|_{B_0} - V_0|_{A_0}$$

where the inequality follows from the fact that \dot{V}_0 is a function of x alone, and that, for given x , $y - F(x)$ is larger on \mathcal{C}_1 than on \mathcal{C}_0 . For the part of the orbit B_1C_1

$$V_0|_{B_1} - V_0|_{C_1} = \int_{C_1}^{B_1} \dot{V}_0 dt = \int_{C_1}^{B_1} \dot{V}_0 \frac{dy}{x} > \int_{C_0}^{B_0} \dot{V}_0 \frac{dy}{x} = V_0|_{B_0} - V_0|_{C_0}$$

where the inequality follows from the fact that \dot{V}_0/x is an increasing function of x and that for given y such that $-y_0 < y < \bar{y}_0$, the value of x is greater on \mathcal{C}_1 than on \mathcal{C}_0 , with the integral along \mathcal{C}_1 also having positive contributions from $-y_1 < y < -y_0$ and $\bar{y}_0 < y < \bar{y}_1$. It follows that

$$V_0|_{B_1} - V_0|_{C_1} > V_0|_{B_0} - V_0|_{C_0} = V_0|_{B_0} - V_0|_{A_0} > V_0|_{B_1} - V_0|_{A_1}.$$

Hence $V_0|_{C_1} < V_0|_{A_1}$ and the orbit \mathcal{C}_1 is not closed.

5 Bifurcations

5.1 Introduction

We return now to the notion of dynamical systems depending on one or more **parameters** μ_1, μ_2, \dots . We are interested in parameter values for which the system is not **structurally stable**. Recall the definitions:

Definition 25 (Topological equivalence). Two vector fields \mathbf{f} \mathbf{g} and associated flows $\phi^{\mathbf{f}}$, $\phi^{\mathbf{g}}$ are **topologically equivalent** if \exists a homeomorphism (1-1, continuous, with continuous inverse) $h : \mathbb{R}^n \rightarrow \mathbb{R}^n$, and a map $\tau(t, \mathbf{x}) \rightarrow \mathbb{R}$, strictly increasing on t , s.t.

$$\tau(t + s, \mathbf{x}) = \tau(s, \mathbf{x}) + \tau(t, \phi_s^{\mathbf{f}}(\mathbf{x})), \text{ and } \phi_{\tau(t, \mathbf{x})}^{\mathbf{g}} h(\mathbf{x}) = h(\phi_t^{\mathbf{f}}(\mathbf{x}))$$

(Structural stability). The vector field \mathbf{f} is **structurally stable** if for all twice differentiable vector fields $\mathbf{v} \exists \epsilon_v > 0$ such that \mathbf{f} is topologically equivalent to $\mathbf{f} + \epsilon \mathbf{v}$ for all $0 < \epsilon < \epsilon_v$.

It turns out that if for a given $\mathbf{f}(\mathbf{x}, \boldsymbol{\mu})$ we vary the ^{set} of parameters $\boldsymbol{\mu}$ then we will have structural stability in general except on certain sets in $\boldsymbol{\mu}$ -space with dimension less than the entire space. We define a **bifurcation point** as a point in $\boldsymbol{\mu}$ -space where \mathbf{f} is not structurally stable. A **bifurcation** (change in structure of the solution) will occur when $\boldsymbol{\mu}$ is varied to pass through such a point. A **bifurcation diagram** is a plot of e.g the location of the fixed points and the amplitudes of the periodic orbits as functions of $\boldsymbol{\mu}$.

5.2 Stationary bifurcations in \mathbb{R}^2

5.2.1 One-dimensional bifurcations

Stationary bifurcations occur when one eigenvalue of the Jacobian at a given fixed point is zero. These are best understood initially in one dimension. Suppose we have an 1-D dynamical system $\dot{x} = f(x, \boldsymbol{\mu})$, and that when $\boldsymbol{\mu} = 0$ the equation has a fixed point at the origin, which is non-hyperbolic. Thus we have $f(0, 0) = \partial f_x(0, 0) = 0$ (subscripts denote partial derivatives). There are three possible types of bifurcation involving one parameter. The first is the generic case, and the others occur under more restrictive conditions. In each case we can sketch the bifurcation diagram.

1. **Saddle-Node Bifurcation.** $\dot{x} = \mu - x^2$. We have $x = +\sqrt{\mu}$ (stable) and $x = -\sqrt{\mu}$ (unstable) when $\mu > 0$, a saddle-node at 0 when $\mu = 0$ and no fixed points for $\mu < 0$.

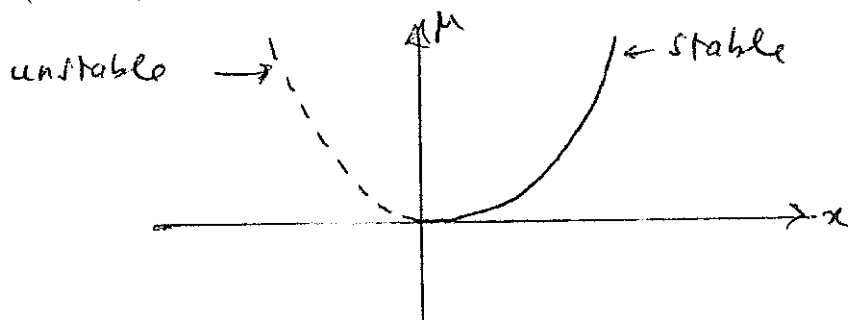

(recall hyperbolic \rightarrow structurally stable)

2. **Transcritical Bifurcation.** $\dot{x} = \mu x - x^2$. There are fixed points at $x = 0, \mu$ which exchange stability at $\mu = 0$.

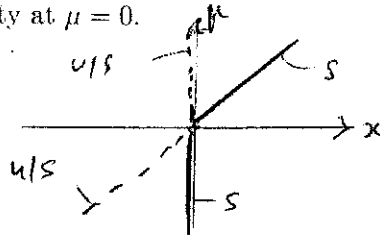

3. **Pitchfork Bifurcation.** $\dot{x} = \mu x \mp x^3$. Fixed point at $x = 0$, also at $x = \pm\sqrt{\pm\mu}$ when $\pm\mu > 0$. The $(\dots - x^3)$ case is called *supercritical*, the other case *subcritical*; in the supercritical case the bifurcating solutions are both stable, in the subcritical case the bifurcating solutions are both unstable.

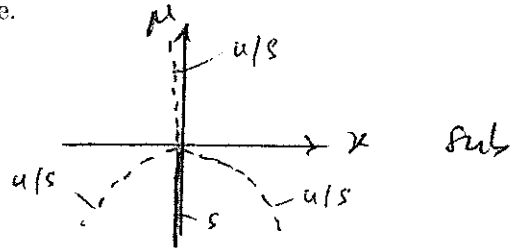
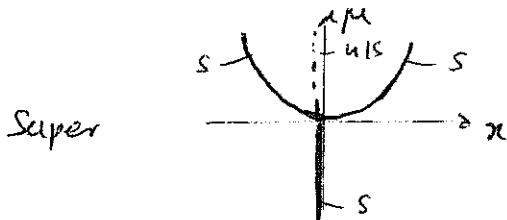

More insight is gained by considering variations of two independent parameters. Suppose we have

$$\dot{x} = \mu_1 + \mu_2 x - x^2$$

This includes both families (1) and (2) as special cases. Fixed points are at

$$x = \frac{\mu_2 \pm \sqrt{\mu_2^2 + 4\mu_1}}{2} \text{ provided that } \mu_2^2 + 4\mu_1 > 0$$

There is a single non-hyperbolic fixed point on the parabola $\mu_2^2 + 4\mu_1 = 0$, and no fixed point if $\mu_2^2 + 4\mu_1 < 0$.

Clearly passing *through* any point of the parabola yields a saddle-node bifurcation. To see a transcritical bifurcation, it is necessary for the path in parameter space to be *tangential* to the parabola. e.g. if we vary μ_2 at fixed μ_1 then in general the only bifurcations are saddle-nodes, except when $\mu_1 = 0$.

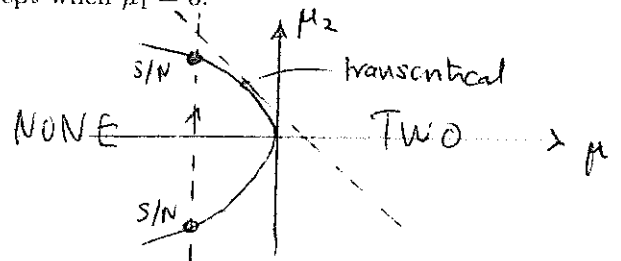

most paths
in μ_1, μ_2 space
see saddle node

We say that the saddle-node bifurcation is **codimension 1** (i.e. in μ -space bifurcation set has a dimension one less than that of the entire parameter space). The o.d.e. $\dot{x} = \mu - x^2$ is a **universal unfolding** of the saddle node $\dot{x} = -x^2$ (i.e. it captures the structure in μ -space around the bifurcation point). We can also say that $\dot{x} = \mu - x^2$ is the **normal form** for the saddle-node bifurcation, in the sense that generic vector fields near the saddle-node can be reduced to this form by a near-identity diffeomorphism.

Example 29 (Reduction to normal form.) Consider the two-parameter family

$$\dot{x} = \mu_1 + \mu_2 x - x^2$$

and try a change of variable $y = x - \alpha$, so that

$$\dot{y} = (\mu_1 + \mu_2 \alpha - \alpha^2) + y(\mu_2 - 2\alpha) - y^2$$

Choosing $\alpha = \mu_2/2$ gives $\dot{y} = (\mu_1 + \mu_2^2/4) - y^2$, which is in the normal form. The more general two-parameter system

$$\dot{x} = \mu_1 + \mu_2 x - Cx^2$$

can be reduced scaling time so that $T = Ct$ to

$$\frac{dx}{dT} = \frac{\mu_1}{C} + \frac{\mu_2}{C}x - x^2$$

assumed $\neq 0$

and so to the normal form.

We can now treat the case of general $f(x, \mu)$ provided that (as we assume) f can be expanded in a Taylor series in both x and μ near the non-hyperbolic (bifurcation) point $(0, 0)$. At this point we already have $f(0, 0) = 0 = f_x(0, 0)$. Now suppose, what is generally true, that $f_{xx} \neq 0$, $f_\mu \neq 0$ at this point. Now we expand f in a double Taylor series about $(0, 0)$:

$$f(x, \mu) = f(0, 0) + xf_x(0, 0) + \mu f_\mu(0, 0) + \frac{x^2}{2} f_{xx}(0, 0) + x\mu f_{x\mu}(0, 0) + \frac{\mu^2}{2} f_{\mu\mu}(0, 0) + \mathcal{O}(x^3, x^2\mu, x\mu^2, \mu^3).$$

Rearranging, we have

$$\begin{aligned} f(x, \mu) &= (\mu f_\mu + \mathcal{O}(\mu^2)) + x(\mu f_{x\mu}) + \frac{x^2}{2} f_{xx} + \mathcal{O}(x^3, x^2\mu, \mu x^2, \mu^3) \\ &= \mu_1 + \mu_2 x + \frac{x^2}{2} f_{xx} + \mathcal{O}(x^3, x^2\mu, \mu x^2, \mu^3) \end{aligned}$$

Robust - most choices of μ_1, μ_2 give saddle-node

and this is in the correct form to be reduced to the standard saddle-node equation. Note that in the second form the μ_i denote parameters that can be freely varied. The coefficient of the x^2 term is not regarded as freely varying since we have made the assumption that this is non-zero.

Following this approach allows us to identify the two special cases mentioned previously, non-generic in the space of all problems, but nonetheless of considerable importance.

- **Transcritical bifurcation.** If the system is such that $f(0, \mu) = 0$ for all μ (or can be put into this form by a change of variable), then $f_\mu(0, 0) = 0$, and we have instead of the above

$$f(x, \mu) = \mu_2 x + \frac{x^2}{2} f_{xx} + \mathcal{O}(x^3, x^2\mu, \mu x^2)$$

with all the higher order terms vanishing when $x = 0$. This is in the normal form for a transcritical bifurcation.

- Pitchfork bifurcation.** If the system has a *symmetry*; that is if the equation is unchanged under an operation on the space variables whose square is the identity, then simple bifurcations are pitchforks. In \mathbb{R} the only such operation is $x \rightarrow -x$; for the equations to be invariant f must be odd in x . Then expanding in the same way we get $f(x, \mu) = \mu_2 x + \frac{1}{3} f_{xxx} x^3 + \mathcal{O}(x^5, \mu x^3, \dots)$. (In higher dimensions symmetries can take more complicated form. For example, the system $\dot{x} = \mu x - xy, \dot{y} = -y + x^2$ has symmetry under $x \rightarrow -x, y \rightarrow y$).

The saddle-node bifurcation is robust under small changes of parameters as shown above. But transcritical and pitchfork bifurcations depend on the vanishing of terms, and therefore change under small perturbations.

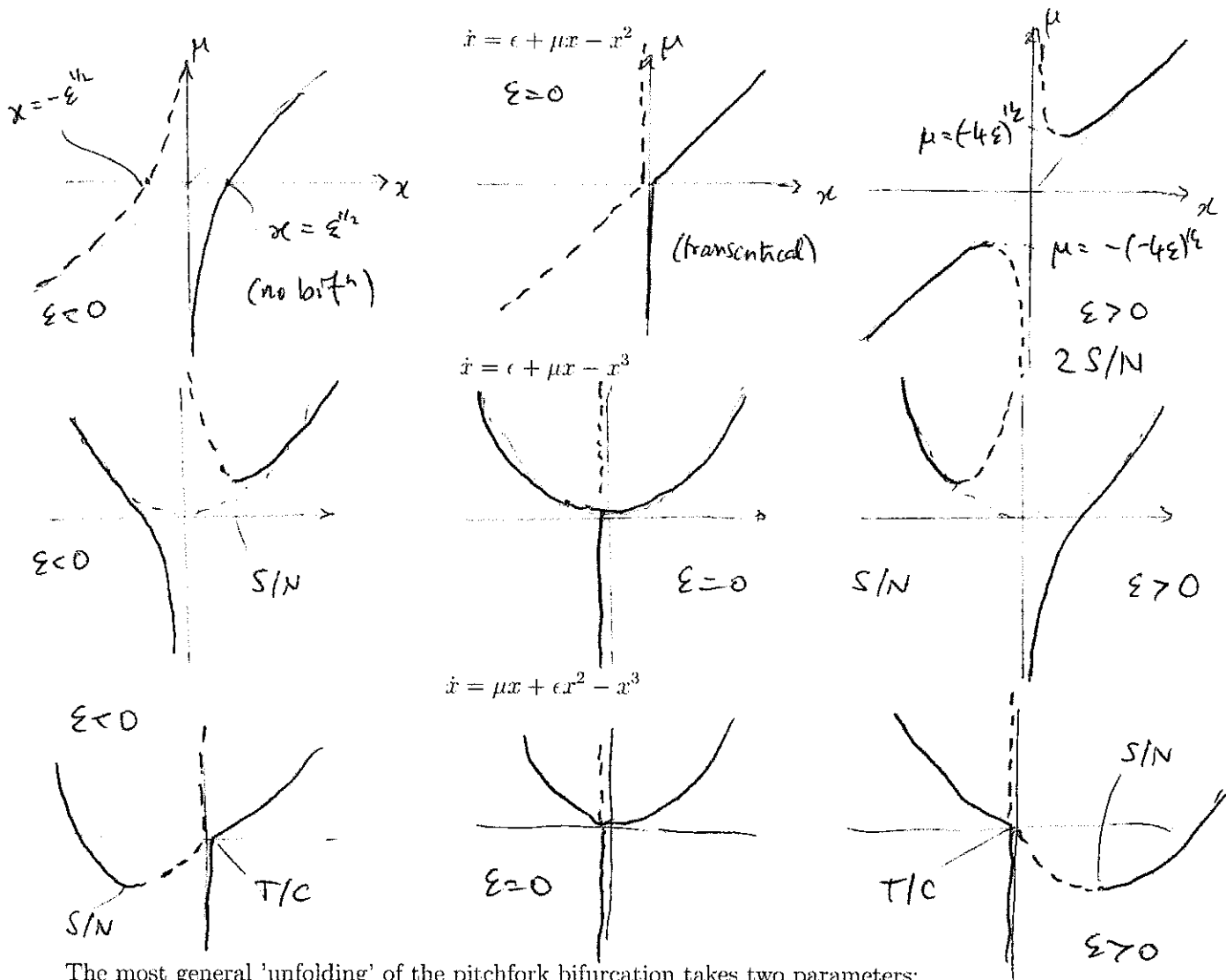

The most general 'unfolding' of the pitchfork bifurcation takes two parameters:

$$\dot{x} = \epsilon_1 + \mu x + \epsilon_2 x^2 - x^3$$

(Diagram: exercise)

5.2.2 Bifurcations in \mathbb{R}^2

A fixed point for a 2-D dynamical system is non-hyperbolic if there is at least one purely imaginary (or zero) eigenvalue.

Consider the situation where $\dot{\mathbf{x}} = \mathbf{f}(\mathbf{x}, \mu)$ has a non-hyperbolic fixed point at the origin, for some value μ_0 of μ . There are four cases:

- (i) $\lambda_1 = 0, \text{Re}(\lambda_2) \neq 0$. This is a **simple**, or **steady-state** bifurcation, and is essentially the same as the 1D examples shown above. We show this below when we discuss the centre manifold.
- (ii) $\lambda_{1,2} = \pm i\omega, \text{Re}(\lambda_j) \neq 0, j \neq 1, 2$. This is an **oscillatory** or **Hopf** bifurcation, and leads to the growth of oscillations.
- (iii) and (iv) There are two zero eigenvalues. Canonical form of matrix A is either $\begin{pmatrix} 0 & 0 \\ 0 & 0 \end{pmatrix}$ (**double-zero bifurcation**), or $\begin{pmatrix} 0 & 1 \\ 0 & 0 \end{pmatrix}$ (**Takens-Bogdanov bifurcation**). They have quite different properties and are not seen generically as they need two separate conditions on the parameters to be satisfied.

Note that there are extra technical requirements on the way the eigenvalues change with μ (e.g. for (i) we must have $d\lambda_1/d\mu \neq 0$ at $\mu = \mu_0$). We shall look at only (i) and (ii) in detail.

5.3 The Centre Manifold

Consider first the simple bifurcation identified above. By analogy with the hyperbolic case, when $\mu = \mu_0$ the linear system has a subspace on which the solutions decay (or grow) exponentially, and another in which the dynamics is non-hyperbolic (the **centre eigenspace** as defined below). For example, for a saddle node we have $\dot{x} = x^2, \dot{y} = -y$, so solutions decay on the y -axis and the dynamics is non-hyperbolic on the x -axis. By analogy with the stable and unstable manifolds and their relation to the stable and unstable subspaces in the hyperbolic case, we might expect a manifold to exist (the **centre manifold**), which is tangent to the centre eigenspace at the origin, and on which the dynamics correspond to that in the centre eigenspace.

Example 30 Consider the non-hyperbolic system

$$\begin{pmatrix} \dot{x} \\ \dot{y} \end{pmatrix} = \begin{pmatrix} x^2 + xy + y^2 \\ -y + x^2 + xy \end{pmatrix}.$$

The linear system has $\dot{y} = -y$ and so trajectories approach $y = 0$, which is the centre eigenspace. In this space $\dot{x} = x^2$. It turns out that there is an invariant manifold tangent to $y = 0$ at the origin on which $\dot{x} \sim x^2$, (the **Centre Manifold** or **CM**).

This is formalised in the Centre Manifold Theorem below, but note that CM's are not like stable and unstable manifolds in that they are not unique (see Example Sheet 2, Q1).

We can find the CM in this example, assuming existence, by expansion. Suppose it is of form $y = p(x) \equiv a_2x^2 + a_3x^3 + a_4x^4 + \dots$. Then $\dot{y} = -p + x^2 + xp = \dot{x}p_x = (x^2 + xp + p^2)p_x$. This o.d.e. for $p(x)$ cannot be solved in general, but substitute the expansion for p , equate coefficients and get $a_2 = 1, a_3 = -1, a_4 = 0$. Thus the CM is given by $p(x) = x^2 - x^3 + \mathcal{O}(5)^*$. The dynamics on the CM is then given by replacing y by p in the equation for \dot{x} :

$$\dot{x} = x^2 + xp + p^2 = x^2 + x^3 - x^4 + \mathcal{O}(6)^* + x^4 - 2x^5 + \mathcal{O}(6) = x^2 + x^3 - 2x^5 + \mathcal{O}(6)^*,$$

and so close to the origin we have $\dot{x} \sim x^2$ as expected so that we have a saddle-node for the nonlinear system.

***Notation:** The notation $\mathcal{O}(m)$ is used to mean terms that are of total power m in the relevant variables, e.g. if the variables are a and b then terms a^3, a^2b, ab^2 and b^3 are all $\mathcal{O}(3)$.

The existence of a centre manifold is guaranteed under appropriate conditions by the **Centre Manifold Theorem**:

Theorem 13 (Centre Manifold Theorem). Given a dynamical system $\dot{\mathbf{x}} = \mathbf{f}(\mathbf{x})$ in \mathbb{R}^n with a non-hyperbolic fixed point at the origin O , let E^c be the (generalised) linear eigenspace corresponding to eigenvalues of $A = D\mathbf{f}|_0$ with zero real part (the **centre subspace**), and E^h the complement of E^c (the **hyperbolic subspace**). Choose a coordinate system (\mathbf{c}, \mathbf{h}) , $\mathbf{c} \in E^c$, $\mathbf{h} \in E^h$ and write the o.d.e. in the form

$$\begin{pmatrix} \dot{\mathbf{c}} \\ \dot{\mathbf{h}} \end{pmatrix} = \begin{pmatrix} \mathbf{C}(\mathbf{c}, \mathbf{h}) \\ \mathbf{H}(\mathbf{c}, \mathbf{h}) \end{pmatrix}.$$

Then \exists a function $\mathbf{p} : E^c \rightarrow E^h$ with graph $\mathbf{h} = \mathbf{p}(\mathbf{c})$, called the **centre manifold** which has properties:

- (i) is tangent to E^c at O ;
- (ii) is locally invariant under \mathbf{f} ;
- (iii) dynamics is topologically equivalent to

$$\begin{pmatrix} \dot{\mathbf{c}} \\ \dot{\mathbf{h}} \end{pmatrix} = \begin{pmatrix} \mathbf{C}(\mathbf{c}, \mathbf{p}(\mathbf{c})) \\ \left. \frac{\partial \mathbf{H}}{\partial \mathbf{h}} \right|_0 \mathbf{h} \end{pmatrix}$$

- (iv) $\mathbf{p}(\mathbf{c})$ can be approximated by a polynomial in \mathbf{c} in some neighbourhood of O .

Thus in Example 29, $c = x, h = y$ and $p(x) = x^2 - x^3 + \dots$; local dynamics is equivalent to $\dot{x} = x^2 + xp(x) + p(x)^2, \dot{y} = -y$

This is very helpful for non-hyperbolic systems, but we believe that such reductions ought to be possible *near*, and not just *at*, bifurcation points. We can use the centre manifold theorem by means of a trick.

in (x, μ) space

To our original system $\dot{x} = f(x, \mu)$, which now has a *hyperbolic* fixed point at 0, adjoin the equations $\dot{\mu} = 0$. We now have a system in $\mathbb{R}^{(n+m)}$, where m is the number of parameters. In this new system the terms giving the linearized growth rates as functions μ will be *nonlinear*, and so we are at a non-hyperbolic fixed point of the extended system, and can use the CM theorem to reduce the system.

Example 31 Consider the system

$$\begin{pmatrix} \dot{x} \\ \dot{y} \end{pmatrix} = \begin{pmatrix} \mu + x^2 + xy + y^2 \\ 2\mu - y + x^2 + xy \end{pmatrix}.$$

Regarding μ as a variable we have

$$\begin{pmatrix} \dot{x} \\ \dot{\mu} \\ \dot{y} \end{pmatrix} = \begin{pmatrix} 0 & 1 & 0 \\ 0 & 0 & 0 \\ 0 & 2 & -1 \end{pmatrix} \begin{pmatrix} x \\ \mu \\ y \end{pmatrix} + \text{nonlinear terms.}$$

The centre (generalised) eigenspace is $y = 2\mu$, which is a plane in \mathbb{R}^3 (note that in the linearised system all initial conditions tend to this plane), and the CM is of the form

$$y = p(x, \mu) = 2\mu + a_{20}x^2 + a_{11}x\mu + a_{02}\mu^2 + \dots,$$

we have

$$\dot{y} = 2\mu - p + x^2 + xp = -\frac{\partial p}{\partial x}(\mu + x^2 + xy + y^2) + \frac{\partial p}{\partial \mu} \cdot 0, \text{ or}$$

$$\begin{aligned} 2\mu + (2\mu + a_{20}x^2 + a_{11}x\mu + a_{02}\mu^2 + \dots)(x - 1) + x^2 \\ = (\mu + x^2 + x(2\mu + a_{20}x^2 + a_{11}x\mu + a_{02}\mu^2 + \dots)) + \\ + (2\mu + a_{20}x^2 + a_{11}x\mu + a_{02}\mu^2 + \dots)^2 (2a_{20}x + a_{11}\mu + \dots) \end{aligned}$$

Equating coefficients, we find $[x^2]: a_{20} = 1, [x\mu]: a_{11} = 0, [\mu^2]: a_{02} = 0$. Thus the CM is given by $y = p(x, \mu) = 2\mu + x^2 + \mathcal{O}(3)$, and the dynamics on the extended CM is given by

$$\dot{x} = \mu + x^2 + x(2\mu + \dots) + 4\mu^2 + \dots$$

$$\dot{\mu} = 0$$

This is clearly (cf. the one-parameter families above) a saddle-node bifurcation when $\mu = 0$.

The corresponding general (and important) result is that for a dynamical system in \mathbb{R}^n , with a simple bifurcation at μ_0 (i.e. the system has a single zero eigenvalue at $\mu = \mu_0$, and (wlog) all eigenvalues are in the left-hand half plane for $\mu = \mu_0^-$, and there is just one eigenvalue in the right-hand half-plane for $\mu = \mu_0^+$), there is a centre manifold, the dynamics is essentially one-dimensional and the bifurcation is generically a saddle-node.

i.e. the 1-D bifurcation models described earlier describe behaviour on CM

5.4 Oscillatory/Hopf Bifurcations in \mathbb{R}^2

The simplest model of a Hopf (oscillatory) bifurcation is given by the system (in polar coordinates) $\dot{r} = \mu r - r^3, \dot{\theta} = 1$. For $\mu < 0$ we have a stable focus, and for $\mu > 0$ an unstable focus and a stable periodic orbit $r = \sqrt{\mu}$. This is a **supercritical Hopf**. If instead we have $\dot{r} = \mu r + r^3$ then the periodic orbit exists when $\mu < 0$, and is unstable (**subcritical Hopf**).



It turns out that generically all dynamical systems can be put into this form in the neighbourhood of a Hopf bifurcation. We need a technical definition of this bifurcation.

Definition 26 (Hopf bifurcation). Suppose we have a dynamical system $\dot{\mathbf{x}} = \mathbf{f}(\mathbf{x}, \mu) = (f(\mathbf{x}, \mu), g(\mathbf{x}, \mu))$ which at $\mu = 0$ has a fixed point at 0, and has linearization A satisfying $\det A > 0, \text{Tr} A = 0$ [so that the linearization has eigenvalues $\lambda_{1,2}(0) = \pm i\omega$], and that $d(\text{Re}(\lambda_{1,2})/d\mu > 0$ at $\mu = 0$. Then provided a constant γ , defined as the value at $\mu = 0$ of

$$\frac{1}{16} (f_{xxx} + g_{yyy} + f_{xyy} + g_{xyy} + \omega^{-1}(f_{xy}(f_{xx} + f_{yy}) - g_{xy}(g_{xx} + g_{yy}) - f_{xx}g_{xx} + f_{yy}g_{yy}))$$

is not equal to zero, then there is a Hopf bifurcation at $\mu = 0$ and there is a stable limit cycle for $\mu = 0^+$ if $\gamma < 0$ (**supercritical Hopf bifurcation**) and an unstable limit cycle for $\mu = 0^-$ if $\gamma > 0$ (**subcritical Hopf bifurcation**).

Remark: because A is not singular at $\mu = 0$, there is no change in the number of fixed points for small $|\mu|$. The exact form of γ above is complicated, but you will not be required to remember it or derive it and examples will typically consider equations that are in an easily recognizable form. Rather than derive the formula (see §8.9 of Glendinning if interested) we show how the equation can be brought into the normal form at $\mu = 0$ by a near identity diffeomorphism.

Take $\mu = 0$ and choose canonical coordinates so that $A = \begin{pmatrix} 0 & -\omega \\ \omega & 0 \end{pmatrix}$. Then writing (in these coordinates) $z = x + iy$, the linear part of the problem is $\dot{z} = i\omega z$. Then the full equation must take the form

$$\dot{z} = i\omega z + \alpha_1 z^2 + \alpha_2 z z^* + \alpha_3 z^{*2} + \mathcal{O}(3)$$

Define a new complex variable ξ by $\xi = z + a_1 z^2 + a_2 z z^* + a_3 z^{*2}$. We try to choose $a_{1,2,3}$ so that $\dot{\xi} = i\omega \xi + \mathcal{O}(3)$. In fact

$$\begin{aligned} \dot{\xi} &= \dot{z}(1 + 2a_1 z + a_2 z^*) + \dot{z}^*(a_2 z + 2a_3 z^*) \text{ so correct to } \mathcal{O}(3), \\ i\omega(z + a_1 z^2 + a_2 z z^* + a_3 z^{*2}) &= (i\omega z + \alpha_1 z^2 + \alpha_2 z z^* + \alpha_3 z^{*2})(1 + 2a_1 z + a_2 z^*) \\ &\quad + (-i\omega z^* + \alpha_1^* z^{*2} + \alpha_2^* z z^* + \alpha_3^* z^2)(a_2 z + 2a_3 z^*) \end{aligned}$$

Equating coefficients of the quadratic terms we get

$$i\omega a_1 = \alpha_1 + 2i\omega a_1; \quad i\omega a_2 = \alpha_2 + i\omega a_2 - i\omega a_2; \quad i\omega a_3 = \alpha_3 - 2i\omega a_3$$

and clearly these equations can be solved. Thus in the transformed system there are no quadratic terms. Attempting the same procedure at cubic order, we find that all the cubic terms can be removed except the term $\propto z^2 z^*$ [Exercise]. Thus after all the transformations have been completed we are left with the equation

$$\dot{z} = i\omega z + \nu z^2 z^* + h.o.t., \quad \text{or } \dot{r} = \text{Re}(\nu)r^3, \quad \dot{\theta} = \omega + \text{Im}(\nu)r^2$$

and $\gamma \propto \text{Re}(\nu)$.

To find the canonical equation when $\mu \neq 0$ we can either use the same ideas on the extended CM that we used for the simple bifurcation, or just add the relevant linear terms; which can be shown to yield the same result in non-degenerate cases.

Note that the normal form is appropriate only when r is sufficiently small. But note that since the constant part of $\dot{\theta}$ is of order unity there is a neighbourhood of the origin in which there are no fixed points.

Example 32 Find the nature of the Hopf bifurcation for the system $\dot{z} = (\mu + i\omega)z + \alpha z^2 + \beta |z|^2$.

Clearly bifurcation point is at $\mu = 0$, so choose this value and, guided by above analysis, choose $\xi = z + az^2 + b|z|^2$. Then

$$\begin{aligned} \dot{\xi} &= (i\omega z + \alpha z^2 + \beta |z|^2)(1 + 2az + bz^*) + (-i\omega z^* + \alpha^* z^{*2} + \beta^* |z|^2)bz \\ &= i\omega z + (\alpha + 2ia)z^2 + \beta |z|^2 + |z|^2 z(2a\beta + \alpha b + b\beta^*) + \text{other cubic} \\ &= i\omega(\xi - az^2 - b|z|^2) + (\alpha + 2ia)z^2 + \beta |z|^2 + |z|^2 z(2a\beta + \alpha b + b\beta^*) + \text{other cubic} \end{aligned}$$

Now choose $i\omega a = -\alpha$: $i\omega b = \beta$. Then quadratic terms vanish, and

$$= i\omega \xi + (i\omega)^{-1}(|\beta|^2 - \alpha\beta)|\xi|^2 \xi + \text{other cubic} + \mathcal{O}(4)$$

so that $\text{Re}(\nu) = -\text{Im}(\alpha\beta)/\omega$.

In fact it can be shown by successive transformations that the canonical form for the dynamics on the CM for a Hopf bifurcation is $\dot{z} = zF(|z|^2)$, where F is a complex valued function with $F(0) = i\omega$. This allows the treatment of degenerate situations for which $\text{Re}(\nu) = 0$.

For higher dimensional systems the CM theorem can be invoked to show that in the neighbourhood of a Hopf bifurcation there is a 2-dimensional (extended) CM on which the dynamics can be put into the above form.

5.5 *Bifurcations of periodic orbits*

(a) Homoclinic bifurcation

This is the simplest 'global' bifurcation and occurs when the stable and unstable manifolds of a saddle point intersect at a critical value μ_0 of the parameter.

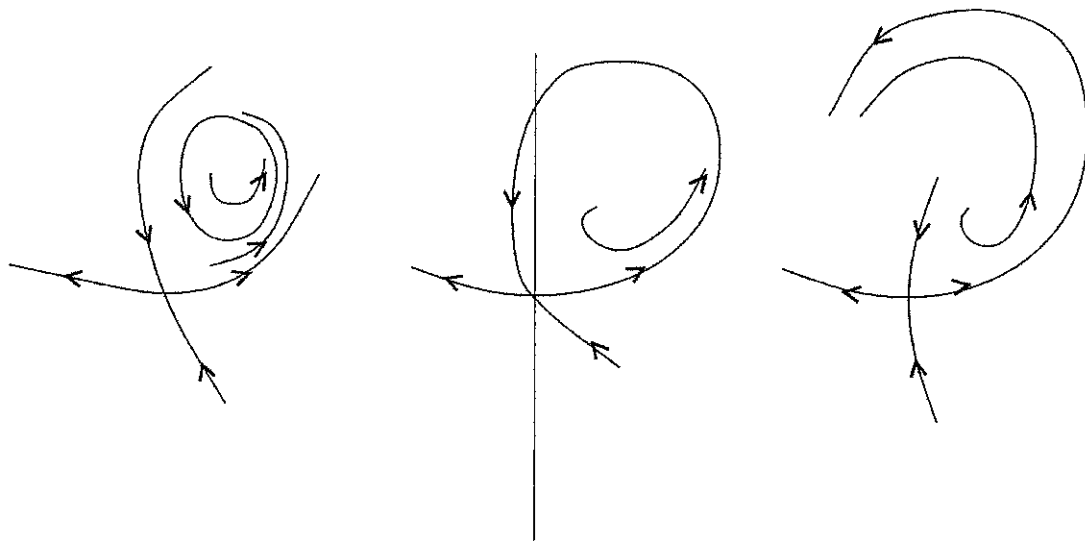

(b) 'Andronov bifurcation'

A different type of bifurcation arises when a saddle-node develops on a periodic orbit ('Andronov bifurcation').]

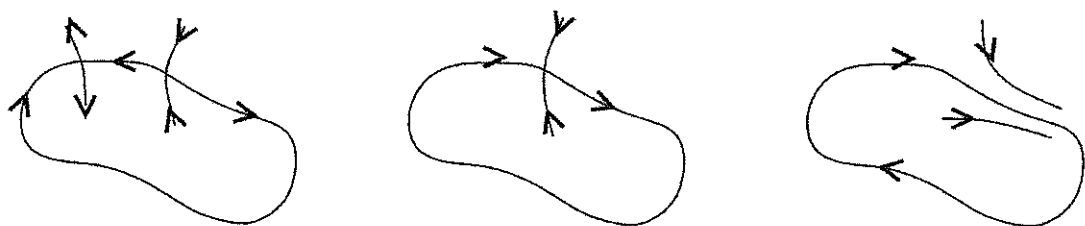

In each of the above cases, periodic orbits are created (or destroyed) as a result of the bifurcation.

6 Bifurcations in Maps

6.1 Examples of maps

We have seen that the study of the dynamics of flows near periodic orbits can be naturally expressed in terms of a map (the Poincaré map). This helps to motivate the study of maps in their own right. There are other motivations too.

- Maps of the interval.** These can be motivated as discrete versions of 1D flows, e.g. suppose we have the ordinary differential equation $\dot{x} = F$ and consider discrete time intervals $t_0, t_1, \dots, t_n \equiv t_0 + n\Delta t, \dots$, with $x(t_n) = x_n$ then Euler's method gives $x_{n+1} = x_n + \Delta t F(x_n)$. Generalising gives the general nonlinear map $x_{n+1} = f(x_n)$. (Another motivation is x_n as a population at the n th generation and f defining the evolution from one generation to the next.) Famous example is the **Logistic (quadratic) map** :

$$x_{n+1} = f(x_n) = \mu x_n(1 - x_n) \quad 0 < x_n \leq 1: \quad 0 \leq \mu \leq 4.$$

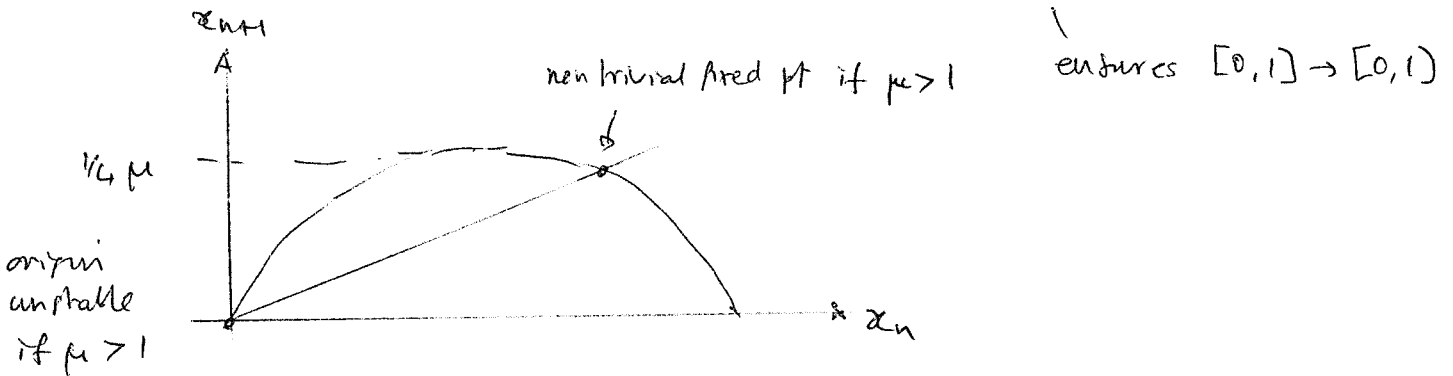

Another important map (since calculations are easy!) is the **Tent (piecewise linear) map**. An example is

$$x_{n+1} = \begin{cases} \mu x_n & 0 \leq x_n \leq \frac{1}{2} \\ \mu(1 - x_n) & \frac{1}{2} \leq x_n \leq 1 \end{cases} \quad 0 < x_n \leq 1: \quad 0 \leq \mu \leq 2$$

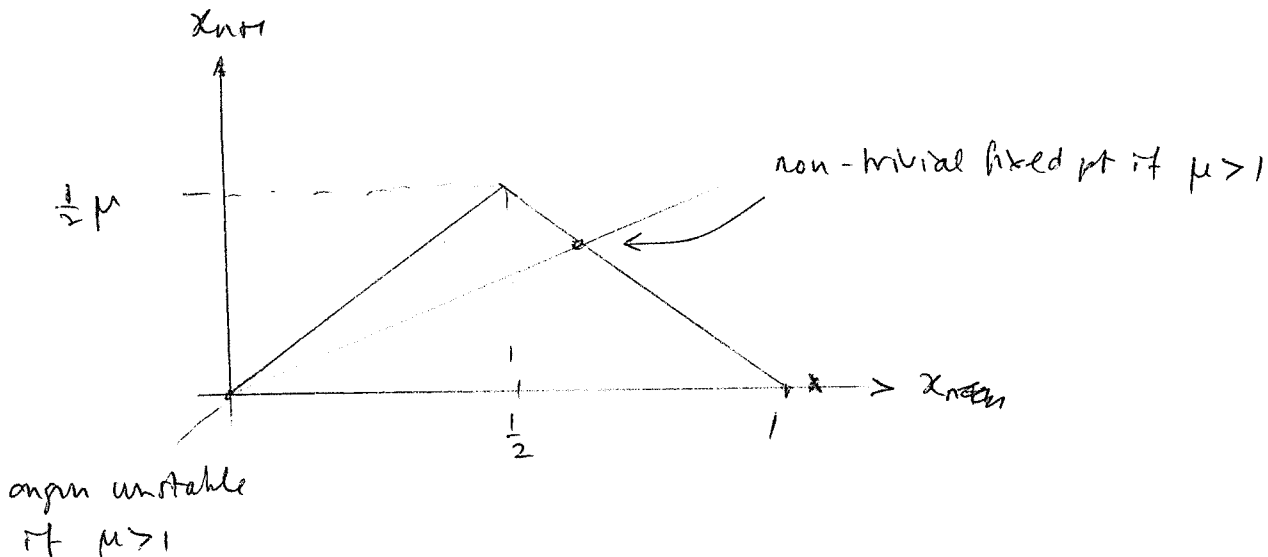

- **Circle Maps.** These are convenient models in which to study a rich variety of behaviour demonstrated by more general maps. Use units in which the circumference of the circle is unity.

Rotation. $x_{n+1} = x_n + \omega \pmod{1}$. This is *periodic* if ω rational, *aperiodic* if ω irrational.

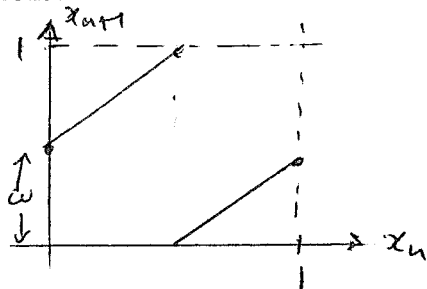

Standard Circle Map. $x_{n+1} = x_n + \mu \sin 2\pi x_n \pmod{1}$. When μ small this is almost the identity, for larger μ get more interesting behaviour. (Introduced by Kolmogorov as a very simple model for the driven mechanical rotor.)

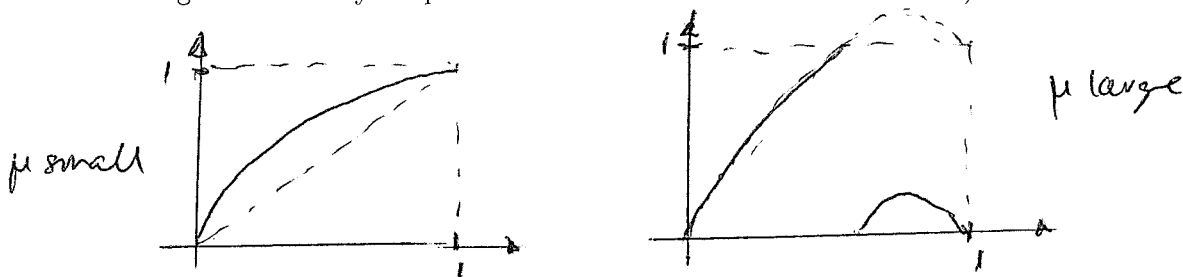

Sawtooth Map (Bernoulli Shift). $x_{n+1} = 2x_n \pmod{1}$. We can find the solution for any x_0 by expressing x_n in binary form: $x_n = 0.i_1i_2i_3\dots i_n\dots$ where the i_j are zero or unity. Then $x_{n+1} = 0.i_2i_3\dots$. So if $x_0 = 0$, $x_n = 0$, if x_0 is rational then binary expansion repeats and so $x_n = x_0$ for some n (periodic) while if x_0 is irrational solution is aperiodic. This map is a prototype of chaotic behaviour.

The shift map can be seen as a special case of the logistic map. Put $x_n = \sin^2 \pi \theta_n$, with θ_n satisfying the shift map. Then $x_{n+1} = \sin^2 2\pi \theta_n = 4x_n(1 - x_n)$ so that x_n satisfies the logistic map with $\mu = 4$. In fact these maps are **topologically conjugate**:

Definition 27 (Topological conjugacy for maps.) Two maps f and g are **topologically conjugate** if there exists a smooth invertible map h such that $f = h^{-1} \cdot g \cdot h$.

- **Maps of the Plane.** These are naturally motivated as Poincaré maps of flows in \mathbb{R}^3 . As such they should be invertible, or at least have unique inverse when an inverse exists.

Hénon Map

$$\begin{pmatrix} x_{n+1} \\ y_{n+1} \end{pmatrix} = \begin{pmatrix} 1 + y_n - ax_n^2 \\ bx_n \end{pmatrix}$$

For appropriate choice of a, b this has ‘strange’ behaviour with fractal structure.

Baker Map. Composed of two maps:

$$\begin{pmatrix} x_{n+1} \\ y_{n+1} \end{pmatrix} = \begin{cases} \begin{pmatrix} 2x_n \\ \frac{1}{2}y_n \end{pmatrix} & 0 < x_n < \frac{1}{2}, 0 < y_n < 1 \\ \begin{pmatrix} 2 - 2x_n \\ 1 - \frac{1}{2}y_n \end{pmatrix} & \frac{1}{2} < x_n < 1, 0 < y_n < 1 \end{cases}$$

So this is a map of $[0 < x < 1, 0 < y < 1]$ into itself.

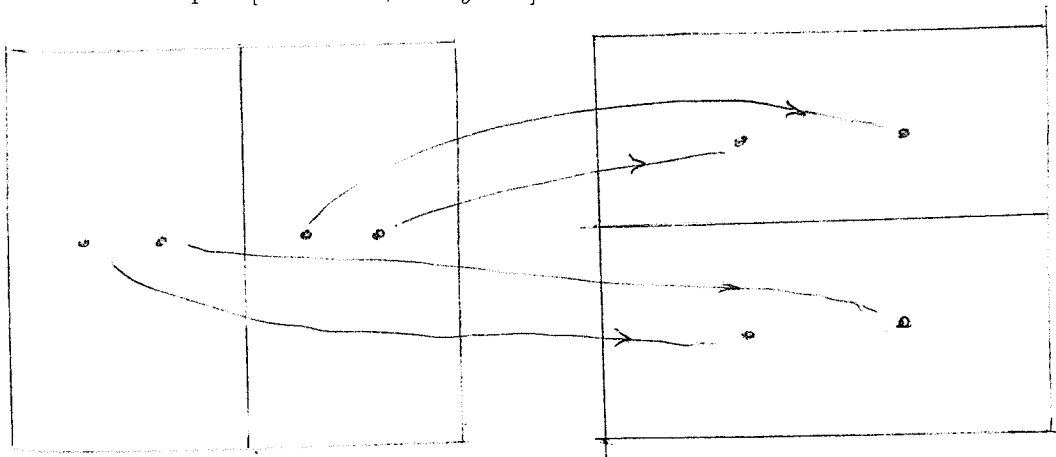

Horseshoe Map (Smale). Best seen in terms of diagram:

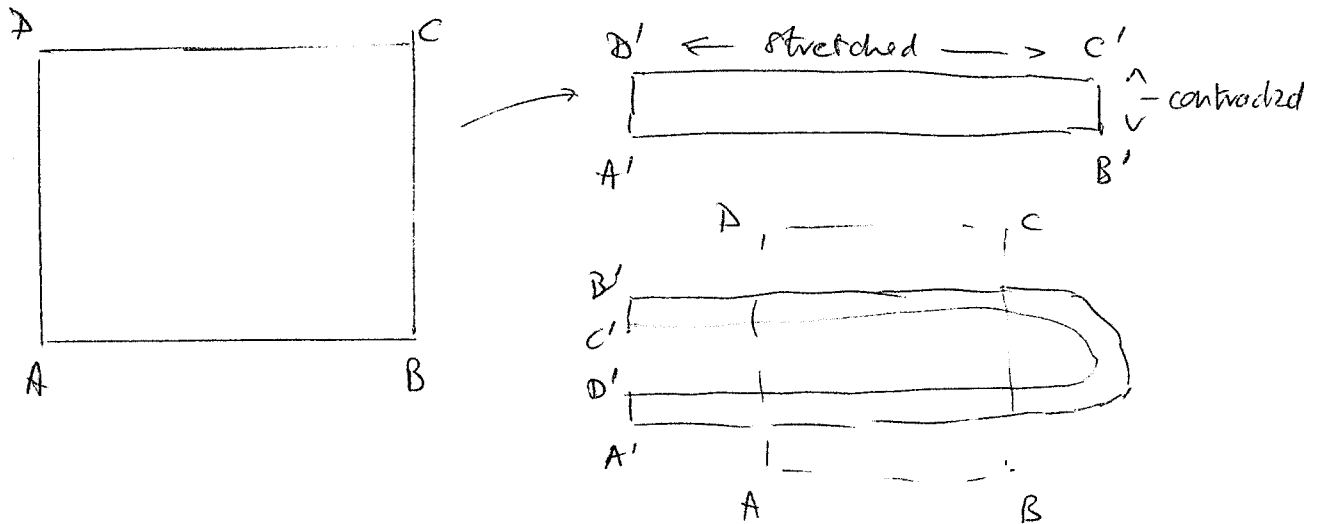

Set of points that do not leave box form a fractal Cantor-type set.

6.2 Fixed points, cycles and stability

We can define, in a manner analogous to that for flows, **fixed points** and **periodic points (cycles)** of a map:

Definition 28 Given a map $\mathbf{x}_{n+1} = \mathbf{f}(\mathbf{x}_n)$, a **fixed point** \mathbf{x}_0 satisfies $\mathbf{x}_0 = \mathbf{f}(\mathbf{x}_0)$. \mathbf{x}_0 is a **periodic point** with **period** n if $\mathbf{x}_0 = \mathbf{f}^n(\mathbf{x}_0)$, $\mathbf{x}_0 \neq \mathbf{f}^m(\mathbf{x}_0)$, $0 < m < n$. Here $\mathbf{f}^2 \equiv \mathbf{f} \circ \mathbf{f}$ (composition), $\mathbf{f}^n = \mathbf{f} \circ \mathbf{f}^{n-1}$. A set of periodic points $\{\mathbf{x}_0, \mathbf{x}_1 = \mathbf{f}(\mathbf{x}_0), \dots, \mathbf{x}_n = \mathbf{f}^n(\mathbf{x}_0) = \mathbf{x}_0\}$ is called a **cycle**.

We can define ω -points (and α -points for invertible maps with inverses) as points of accumulation of iterates of \mathbf{x}_n as $n \rightarrow \infty$ ($-\infty$ for α -points).

We can define notions of Lyapunov stability and quasi-asymptotic stability just as for flows. The notions can be combined into the notion of an **attractor**.

Definition 29 Suppose \mathcal{A} is a closed set mapped into itself by \mathbf{f} . This could be a fixed point, cycle or some more exotic set. We suppose that \mathbf{f} is continuous at points of \mathcal{A} . Then \mathcal{A} is an **attractor** if

(i) For any neighbourhood \mathcal{U} of $\mathcal{A} \exists$ a neighbourhood \mathcal{V} of \mathcal{A} such that for any $\mathbf{x} \in \mathcal{V}$, $\mathbf{f}^n(\mathbf{x}) \in \mathcal{U} \quad \forall n \geq 0$ (Lyapunov stability);

(ii) \exists a neighbourhood \mathcal{W} of \mathcal{A} such that for any $\mathbf{x} \in \mathcal{W}$ and any neighbourhood \mathcal{A}' of $\mathcal{A} \exists n_0$ such that $\mathbf{f}^n(\mathbf{x}) \in \mathcal{A}' \quad \forall n > n_0$ (quasi-asymptotic stability).

Consider a fixed point (chosen to be at the origin) of $\mathbf{x}_{n+1} = \mathbf{f}(\mathbf{x}_n)$, where \mathbf{f} has continuous first derivative at and near the origin. Then we can form the Jacobian matrix $\mathbf{A} = D\mathbf{f}_0$. If we suppose that eigenvalues of \mathbf{A} are distinct or there is a complete set of eigenvectors, then we can show that if all the eigenvalues λ of \mathbf{A} satisfy $|\lambda| < 1$, then the origin is an attractor.

Proof: Let \mathbf{z}_j be the left eigenvectors of \mathbf{A} (possibly complex). Then let $\mathcal{V}_n = \sum v_i |\mathbf{z}_i \cdot \mathbf{x}_n|^2$, for some positive set of numbers v_i . Then $\mathcal{V}_{n+1} = \sum v_i |\mathbf{z}_i \cdot \mathbf{A}\mathbf{x}_n|^2 + \mathcal{O}(|\mathbf{x}_n|^3)$. The first term on the rhs is $\sum v_i |\lambda_i|^2 |\mathbf{z}_i \cdot \mathbf{x}_n|^2 < a^2 \mathcal{V}_n$, where $a^2 = \max |\lambda_i|^2 < (1 - \epsilon)$, $\epsilon > 0$. We can choose \mathcal{V}_n sufficiently small that the cubic remainder term is less than $\epsilon \mathcal{V}_n / 2$, say, and so $\mathcal{V}_n \rightarrow 0$, $n \rightarrow \infty$. Conversely if any eigenvalue λ has $|\lambda| > 1$ the fixed point is a **repellor** (neither QAS nor Lyapunov stable). *Proof: exercise.*

For a cycle of least period r each point of the cycle is a fixed point of the map \mathbf{f}^r , so stability is determined by the eigenvalues of the Jacobian of this map. If we write for each point $\mathbf{x}^{(j)}$ of the cycle $\mathbf{A}^{(j)} \equiv D\mathbf{f}(\mathbf{x}^{(j)})$ the linearization of the map about the cycle can be written $\boldsymbol{\xi}_{n+1} = \mathbf{A}^{(n)} \boldsymbol{\xi}_n$ and so the linearization of \mathbf{f}^r is just $\mathbf{A}^{(r)} \mathbf{A}^{(r-1)} \dots \mathbf{A}^{(1)}$ (can also see this from the chain rule).

6.3 Local bifurcations in 1-dimensional maps

Bifurcations must occur when the eigenvalues of (the linearization of) a map pass through the unit circle. For 1-dimensional maps Jacobians are just real numbers which must pass through ± 1 . We can classify these bifurcations just as for 1-dimensional flows.

- **Saddle-Node.** If we suppose as before that $f = f(x, \mu)$ and that $f(0,0) = 0$, $f_x(0,0) = 1$ then expanding in x, μ as before get

$$x_{n+1} = x_n + \mu f_\mu + \frac{1}{2} x_n^2 f_{xx} + x_n \mu f_{x\mu} + \dots$$

and truncating, shifting the origin and rescaling we get the canonical form

$$x_{n+1} = x_n + \mu - x_n^2$$

which has no fixed points when $\mu < 0$ and two fixed points when $\mu > 0$, for which $x = \pm\sqrt{\mu}$ and the Jacobian is $1 - 2x$. So for $0 < \mu < 1$ one of the fixed points is stable and the other unstable. (Something new happens for $\mu > 1$, but the normal form is understood to apply for sufficiently small μ).

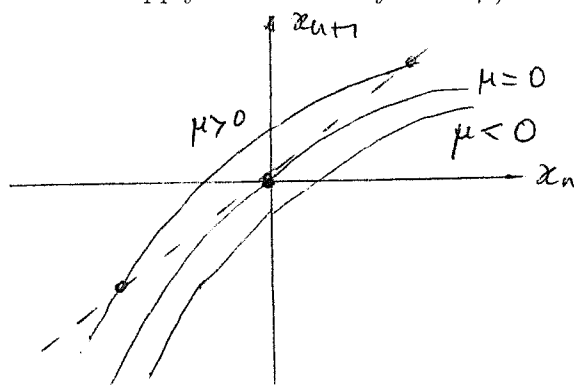

- **Transcritical bifurcation.** Now suppose in addition that $f_\mu(0,0) = 0$; then we have

$$x_{n+1} = x_n + \frac{1}{2}(x_n^2 f_{xx} + \mu^2 f_{\mu\mu}) + x_n \mu f_{x\mu} + \dots$$

Truncating and seeking fixed points, we need $(x^2 f_{xx} + \mu^2 f_{\mu\mu} + 2x\mu f_{x\mu}) = 0$ and this is only possible if $f_{x\mu}^2 > f_{xx} f_{\mu\mu}$. Otherwise there are no fixed points and so no bifurcation. If satisfied can write truncated system in canonical form

$$x_{n+1} = x_n - (x_n - a\mu)(x_n - b\mu)$$

for some a, b . There are two lines of fixed points $x = a\mu$, $x = b\mu$ crossing at origin when $\mu = 0$, each exchanges stability as μ passes through zero. If we write $y_n = x_n - a\mu$, say get even simpler form $y_{n+1} = y_n - y_n(y_n - c\mu)$.

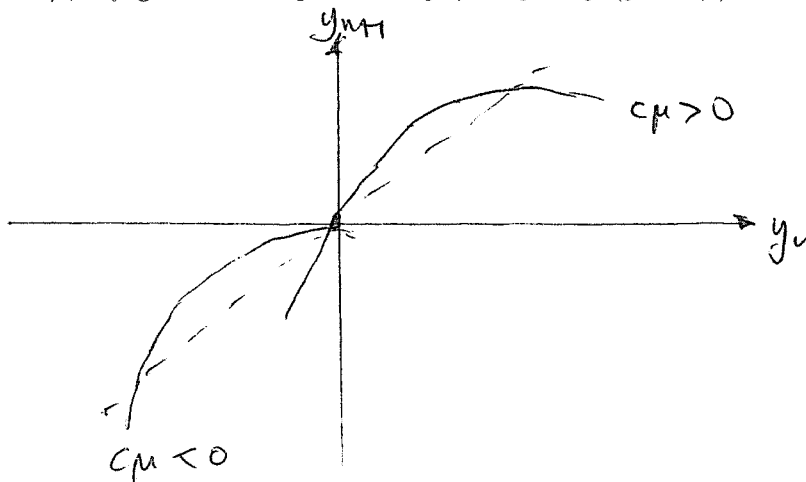

- **Pitchfork bifurcation.** This is achieved as before when the eigenvalue is unity, and if there is a symmetry (equivariance) under $x \rightarrow -x$, in which case only odd terms in x occur in the expansion of f . Then we have

$$x_{n+1} = x_n + \mu x_n \pm x_n^3 + \mathcal{O}(\mu^2 x_n, \mu x_n^3, x_n^5)$$

More generally we get a pitchfork when $f_\mu = f_{xx} = 0$, $f_{\mu x}, f_{xxx} \neq 0$, in which case the correction will include (in general) $\mathcal{O}(\mu x_n^2)$ (but the mapping can be brought to the standard form by a near-identity transformation).

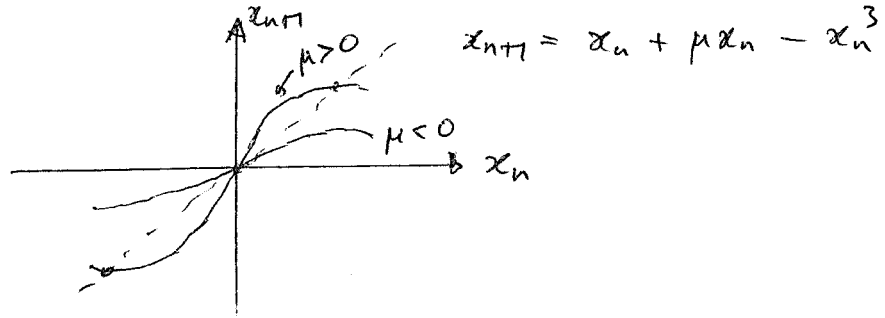

- **Period-doubling bifurcation.** The remaining case has eigenvalue -1 at the bifurcation point. Thus in the general case

$$x_{n+1} = -x_n + a\mu + b\mu x_n + cx_n^2 + dx_n^3 + \mathcal{O}(\mu^2, \mu x_n^2, x_n^4)$$

where $a = f_\mu$, $b = f_{x\mu}$, $c = \frac{1}{2}f_{xx}$ and $d = \frac{1}{6}f_{xxx}$. Consider the map f^2 .

$$x_{n+2} = -x_{n+1} + a\mu + b\mu x_{n+1} + cx_{n+1}^2 + dx_{n+1}^3 + \mathcal{O}(\mu^2, \mu x_n^2, x_n^4),$$

so that

$$x_{n+2} = x_n - a\mu - b\mu x_n - cx_n^2 - dx_n^3 + a\mu + b\mu(-x_n + a\mu + b\mu x_n + cx_n^2) + c(-x_n + a\mu + b\mu x_n + cx_n^2 + dx_n^2)^2 - dx_n^3 + \mathcal{O}(\mu^2, \mu x_n^2, x_n^4).$$

Simplifying and keeping only leading terms we get

$$x_{n+2} = (1 - 2(b + ac)\mu)x_n - 2(c^2 + d)x_n^3 + \mathcal{O}(\mu^2, \mu x_n^2, x_n^4).$$

If we make a change of variable of the form $z_n = x_n + \alpha x_n^2$, (i.e. a near-identity transformation) then we can remove the $\mathcal{O}(\mu x_n^2)$ term to give $z_{n+2} = (1 - 2(b + ac)\mu)z_n - 2(c^2 + d)z_n^3 + \mathcal{O}(\mu^2, \mu z_n^3, z_n^4)$. (Equivalently one can estimate the size of the various terms to show that the $\mathcal{O}(\mu x_n^2)$ term is irrelevant to the form of the bifurcation.) Thus there is a pitchfork bifurcation of f^2 at $\mu = 0$. The nonzero fixed points of f^2 correspond to a 2-cycle of f . It can be shown that if the origin is unstable the 2-cycle is stable and *vice versa*.

7 Chaos

7.1 Introduction

What do we mean by chaos? Two main concepts (a) in a chaotic system, initially nearby orbits separate, and (b) by iterating the map we have some sort of mixing of even the smallest sets, i.e. the iterated image of the set spreads across the domain.

We study chaos in the context of 1-D maps. Consider a continuous map $f : I \rightarrow I$ of a bounded interval $I \subset \mathbb{R}$ into itself, and with $\Lambda \subset I$ a set invariant under f :

Definition 30 *Sensitive dependence on initial conditions.* f has **sensitive dependence on initial conditions** [SDIC] on Λ if $\exists \delta > 0$ s.t. for any $x \in \Lambda$ and $\epsilon > 0 \exists y \in \Lambda$ and $n > 0$ s.t. $|y - x| < \epsilon$, $|f^n(x) - f^n(y)| > \delta$

Note that not all points in the neighbourhood of the selected point x have to separate in this way, and nothing said about exponential divergence.

Definition 31 *Topological Transitivity.* The map f above is **topologically transitive** [TT] on Λ if for any pair of open sets K_1, K_2 s.t. $K_i \cap \Lambda \neq \emptyset$, $i = 1, 2$, $\exists n > 0$ s.t. $f^n(K_1) \cap K_2 \neq \emptyset$. This means that there are orbits that are dense in Λ (proof is beyond this course, but the statement should be at least plausible) i.e. come arbitrarily close to every point of Λ , and so Λ cannot be decomposed into disjoint invariant sets.

Example 33 (TT but not SDIC). The rotation map $x_{n+1} = x_n + \omega \pmod{1}$ is TT on $[0, 1]$ if ω is irrational (though not SDIC).

Example 34 (SDIC but not TT). The map $x_{n+1} = 2x_n$ ($|x_n| < \frac{1}{2}$), $x_{n+1} = 2(\text{sign}(x_n) - x_n)$ ($\frac{1}{2} < |x_n| < 1$) has SDIC on $[-1, 1]$ since $|f'| = 2$, but is not TT on $[-1, 1]$ as $x = 0$ is invariant, $(0, 1)$ maps into $(0, 1)$ and $(-1, 0)$ maps into $(-1, 0)$.

There are two apparently quite different definitions of chaos, though they are more similar than they look.

Definition 32 (Chaos [Devaney]). $f : I \rightarrow I$ is **chaotic** on Λ if (i) f is SDIC on Λ ; (ii) f is TT on Λ ; (iii) periodic points of f are dense in Λ .

The second definition depends on the *Horseshoe property*.

Definition 33 (Horseshoe property). $f : I \rightarrow I$ has a **horseshoe** if $\exists J \subseteq I$, with J an open interval, and disjoint open subintervals K_1, K_2 of J s.t. $f(K_i) = J$ for $i = 1, 2$.

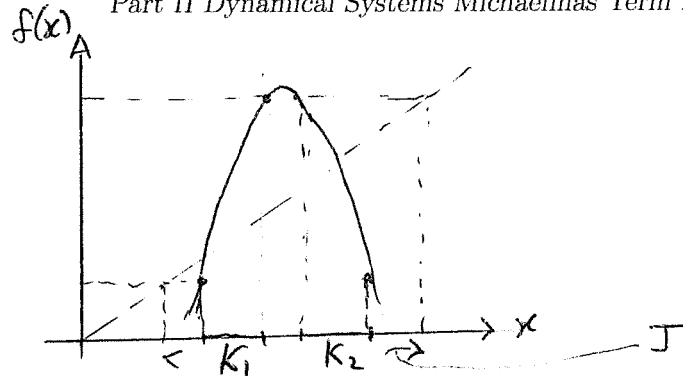

If f has a horseshoe it can be shown that (i) f^n has at least 2^n fixed points; (ii) f has periodic points of every period; (iii) f has an uncountable number of aperiodic orbits.

Definition 34 (Chaos[Glendinning]) A continuous map $f : I \rightarrow I$ is **chaotic** if f^n has a horseshoe for some $n \geq 1$.

This last definition allows for maps with stable fixed points, but demands exponential divergence of nearby trajectories. It will be shown that Chaos[G] \Rightarrow Chaos[D].

7.2 The Sawtooth Map (Bernoulli shift)

As an example consider the **sawtooth map** $f(x) = 2x \pmod{1}$.

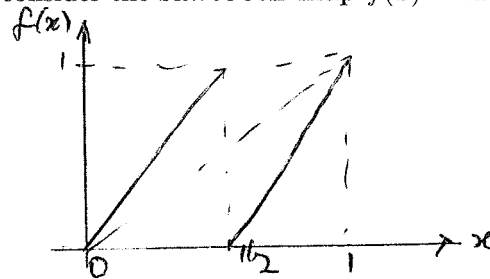

(a) f clearly has a horseshoe with $K_1 = (0, \frac{1}{2})$, $K_2 = (\frac{1}{2}, 1)$. (Note, open sets). So f is chaotic[G].

(b) (i) As in §6 use binary expansion so if $x_n = 0.a_1a_2a_3 \dots$ then $x_{n+1} = 0.a_2a_3 \dots$

If $x \neq y$ then suppose x and y differ first in the $(n + 1)$ th place; then for $r \leq n$ $|f^r(x) - f^r(y)| = 2^r|x - y|$.

Choose $\delta < \frac{1}{2}$. Then given any $x \in [0, 1)$ and $\epsilon > 0$ choose n so that $2^{-n-1} < \epsilon$ and choose y to differ from x *only* in the $n + 1$ binary place. Then $|f^n(y) - f^n(x)| = \frac{1}{2} > \delta$, so f is SDIC.

(ii) Choose any point $x = 0.a_1a_2 \dots$; then for another point $z = 0.b_1b_2 \dots$ choose $y_N = 0.b_1b_2 \dots b_N a_1 a_2 \dots$. Then $f^N(y_N) = x$ and we can make y_N arbitrarily close to z , by taking N sufficiently large (i.e. we have a y_N arbitrarily close to z such that the orbit of y_N includes x), so map is TT.

(iii) Now define $x_N = 0.a_1a_2 \dots a_N a_1 a_2 \dots a_N a_1 \dots$ i.e. expansion repeats after N terms. Repeated application of f gives a cycle of period N . (There are 2^N such cycles.) Furthermore we can make x_N arbitrarily close to x . So periodic points are dense in $[0, 1)$.

Thus f is chaotic[D].

In fact f is a very effective mixer. Define $f(\frac{1}{2}) = 1$ and suppose x is *not* a preimage of $1/2$, i.e. that there is no n s.t. $f^n(x) = \frac{1}{2}$. Thus x does not end with a infinite sequence of 0's (or 1's). Choose m s.t. $a_{m+1} = 0$. Then it is easy to see that $y = 0.a_1 \dots a_m 000 \dots < x < z = 0.a_1 \dots a_m 100 \dots$, and that $f^m(y) = 0, f^m(z) = \frac{1}{2}$. Thus $f^{m+1}((y, z)) = (0, 1)$, and so any arbitrarily small neighbourhood of x can be mapped into the whole interval. (This is because the map is 1-1 on each half range and by construction y, z lie in the same half range and so do $f(y), f(z)$.)

7.3 Horseshoes, symbolic dynamics and the shift map

Aim to show that a map with the horseshoe property acts on a certain invariant set Λ in the same way that as the shift map.

Suppose a continuous map f has a horseshoe on an interval $J \subset \mathbb{R}$ and define the closed intervals $I = \overline{J}, I_i = \overline{K_i}, i = 1, 2$.

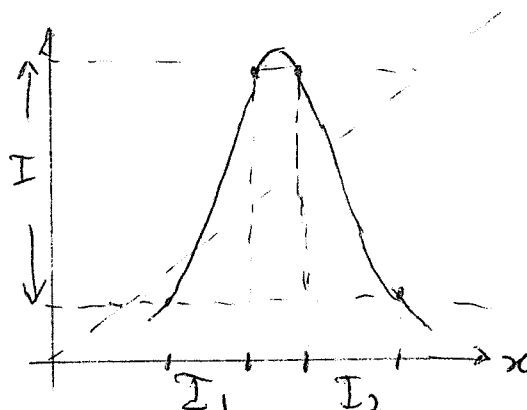

For simplicity assume that f is monotonic on $I_i, I_1 \cap I_2 = \emptyset$ and that $f(x) \in I \Rightarrow x \in I_1$ or I_2 . (Variations from these conditions do not change the conclusions below, but require more complicated arguments.) Define $\Lambda = \{x : f^n(x) \in I, \forall n \geq 0\}$. Clearly $x \in \Lambda \Rightarrow f(x) \in \Lambda$, and $x \in \Lambda \Rightarrow x = f(y)$ for some $y \in I$ (Intermediate value theorem). Since $f^n(y) \in I \forall n \geq 0$ it follows that $y \in \Lambda$. Thus $f(\Lambda) = \Lambda$ so Λ is invariant.

For each $x \in \Lambda, f^n(x) \in I \Rightarrow f^{n-1}(x) \in I_1$ or I_2 . Define $a_n = 0$ if $f^{n-1}(x) \in I_1, a_n = 1$ if $f^{n-1}(x) \in I_2$. Thus x corresponds to the sequence $a_1 a_2 \dots$ while $f(x)$ corresponds to $a_2 a_3 \dots$. This is essentially the same as the action of the shift map on binary expansions of numbers in $[0, 1]$. There are small differences as $0.111 \dots$ and $1.000 \dots$ are the same number but different symbol sequences; however this does not affect the proofs of TT and SDIC, nor the deduction that periodic points are dense in Λ . Thus chaos[G] \Rightarrow horseshoe \Rightarrow chaos[D].

What does Λ look like? The set $f^{-1}(I) \equiv \{x \in I : f(x) \in I\}$ comprises two disjoint closed intervals. So $f^{-n}(I)$ has 2^n closed intervals and $\Lambda = \bigcap_{n=1}^{\infty} f^{-n}(I)$. Limit gives a closed set with an uncountable number of points but length zero, cf. the middle third Cantor set.

7.4 Period 3 implies chaos

Recall the Intermediate Value Theorem: If $f : [a, b] \rightarrow \mathbb{R}$ is continuous, and $f(a) = c, f(b) = d$, then $\forall y \in [c, d] \exists x \in [a, b]$ s.t. $f(x) = y$. In particular if $f(x) - x$ changes sign on $[a, b]$ then $\exists x_0 \in [a, b]$ then $\exists x_0 \in [a, b]$ s.t. $f(x_0) = x_0$. We can now prove the remarkable theorem:

Theorem 14 (Period 3 implies chaos). *If a continuous map f on $I \subseteq \mathbb{R}$ has a 3-cycle then f^2 has a horseshoe and so f is chaotic.*

Proof: let $x_1 < x_2 < x_3$ be the elements of the 3-cycle. wlog suppose $f(x_1) = x_2, f(x_2) = x_3, f(x_3) = x_1$ (otherwise consider instead $-f(-x)$).

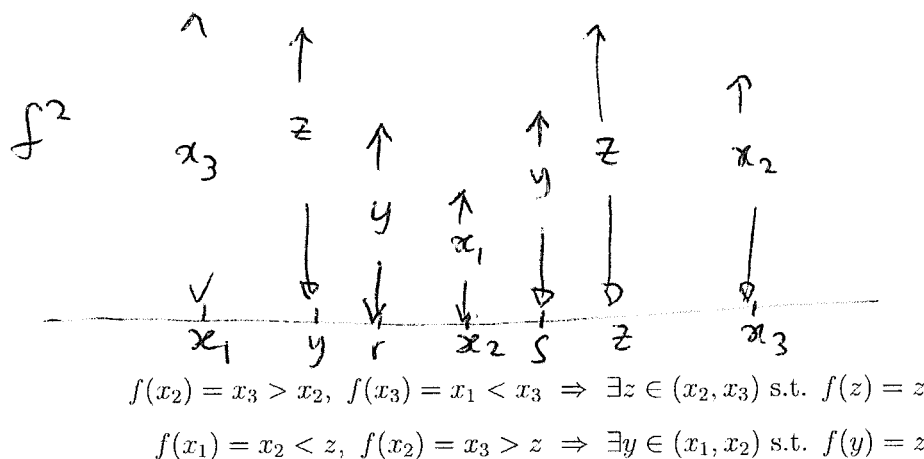

Thus $f^2(y) = f(z) = z > y$ and $f^2(x_2) = x_1 < y$, so \exists a smallest $r \in (y, x_2)$ s.t. $f^2(r) = y$, and \exists largest $s \in (x_2, z)$ s.t. $f^2(s) = y$. Thus f^2 has a horseshoe with $K_1 = (y, r), K_2 = (s, z)$ and $J = (y, z)$.

7.5 Existence of N-cycles

Have shown that f^2 has a horseshoe if there is a 3-cycle, which implies existence of cycles for f^2 of all periods. In fact can show that f has cycles of all periods.

Lemma. Recall that if f is continuous and $V \subseteq f(U)$, where U, V are closed intervals, then \exists a closed interval $K \subseteq U$ s.t. $f(K) = V$.

Theorem 15 *If a continuous map f on $I \subseteq \mathbb{R}$ has a 3-cycle then it has an N -cycle $\forall N \geq 1$.*

Assume $x_1 = f(x_3) < x_2 = f(x_1) < x_3 = f(x_2)$ as before.

$N = 1$: $f(x_3) < x_2 < x_3 = f(x_2) \Rightarrow$ there is a fixed point of the map.

$N > 1$: let $I_L = [x_1, x_2]$, $I_R = [x_2, x_3]$. Then $f(I_L) \supseteq I_R$, $f(I_R) \supseteq I_L \cup I_R$, so $f(I_R) \supseteq I_L$ and $f(I_R) \supseteq I_R$.

Choose $J_N = I_R$. Then define $F(J_{N-1}) = J_N$, noting $J_N \subseteq f(I_L)$ and hence $\exists J_{N-1} \subseteq I_L$ by the Lemma. Similarly, define $J_{N-2}, \dots, J_0 \subseteq I_R$ by $f(J_i) = J_{i+1}$, noting that each $J_{i+1} \subseteq f(I_R)$ and hence each $J_i \subseteq I_R$.

$f^N(J_0) = I_R \Rightarrow \exists a, b \in J_0$ s.t. $f^N(a) = x_2$, $f^N(b) = x_3$. But $J_0 \subseteq I_R$ so $a \geq f^N(a)$, $b \leq f^N(b)$. Thus by IVT there is a fixed point $z \in [a, b] \subseteq J_0$ of f^N .

Now consider whether $z, f(z), f^2(z), \dots, f^{N-1}(z)$ are distinct points in an N -cycle. Certainly $z, f(z), \dots, f^{N-2}(z) \in I_R$ and $f^{N-1}(z) \in I_L$, so for this not to be the case must have $f^{N-1}(z) = x_2 \Rightarrow f^N(z) = x_3 = z$.

But then $f(z) = f(x_3) = x_1 \notin I_R$ so violating construction. Thus $f^{N-1}(z) \neq x_2$ so must not be in I_R . This shows that one iterate is definitely different from all others so we have an N -cycle.

The statements $f(I_L) \supseteq I_R$, $f(I_R) \supseteq I_L \cup I_R$ can be shown as a directed graph:

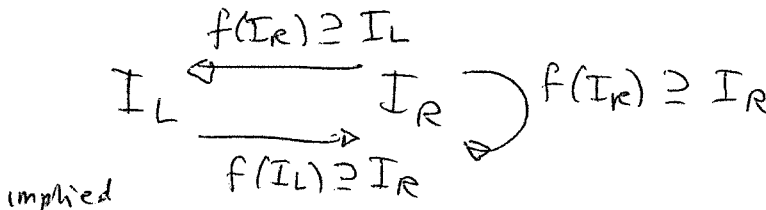

Cycles ~~exist~~ when there are closed paths in the diagram.

Example 35 Suppose there is a 4-cycle $x_1 = f(x_4) < x_3 = f(x_2) < x_2 = f(x_1) < x_4 = f(x_3)$. Let $I_A = [x_1, x_3]$, $I_B = [x_3, x_2]$, $I_C = [x_2, x_4]$. Only fixed points in I_B and 2-cycles between I_A, I_C possible. *implied*

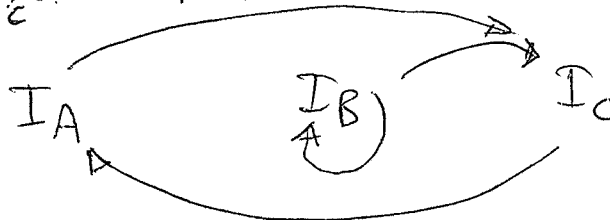

A remarkable result due to Sharkovsky can be proved (proof not in course) by similar methods to the above.

Theorem 16 (Sharkovsky.) If $f : \mathbb{R} \rightarrow \mathbb{R}$ is continuous, f has a k -cycle and $l \triangleleft k$ in the following ordering, then f also has an l -cycle:

$$\begin{aligned}
 &1 \triangleleft 2 \triangleleft 2^2 \triangleleft 2^3 \triangleleft 2^4 \triangleleft \dots \\
 &\dots \\
 &\dots \triangleleft 2^3 \cdot 9 \triangleleft 2^3 \cdot 7 \triangleleft 2^3 \cdot 5 \triangleleft 2^3 \cdot 3 \\
 &\dots \triangleleft 2^2 \cdot 9 \triangleleft 2^2 \cdot 7 \triangleleft 2^2 \cdot 5 \triangleleft 2^2 \cdot 3 \\
 &\dots \triangleleft 2 \cdot 9 \triangleleft 2 \cdot 7 \triangleleft 2 \cdot 5 \triangleleft 2 \cdot 3 \\
 &\dots \triangleleft 9 \triangleleft 7 \triangleleft 5 \triangleleft 3
 \end{aligned}$$

This has many implications, not least that if f has a cycle of period 3 then it has cycles of *all* periods, as proved separately above.

Note that the theorem says nothing about the stability of the cycles. However for the logistic equation at least we know that all cycles either arise from a period-doubling bifurcation, or in the case of the odd-period cycles as a saddle-node bifurcation so they are all stable in some range.

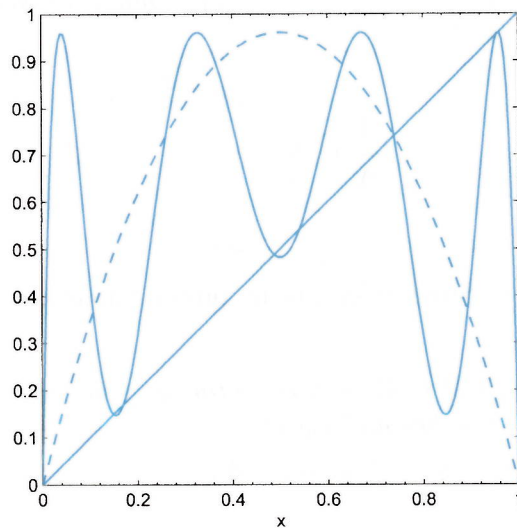
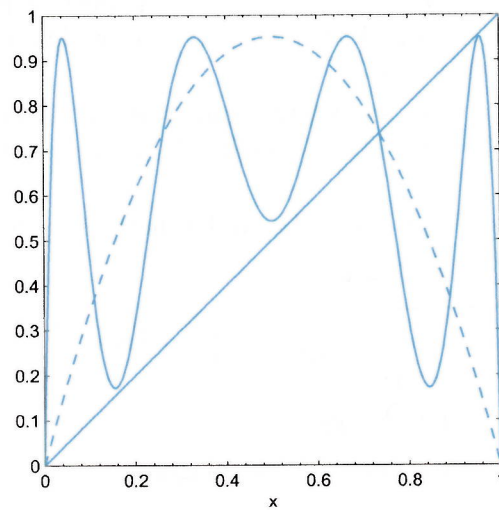

The period-three orbit for the logistic map. Shown is the map f^3 where $f(x) = \mu x(1-x)$: top picture; $\mu = 3.81$, bottom picture; $\mu = 3.84$.

7.6 The Tent Map

A more interesting map than the sawtooth map, because it depends on a parameter, is the tent map $f(x) = \mu[\frac{1}{2} - |x - \frac{1}{2}|]$ Fixed point at 0 stable for $\mu < 1$. Choose $\mu \in (1, 2]$.

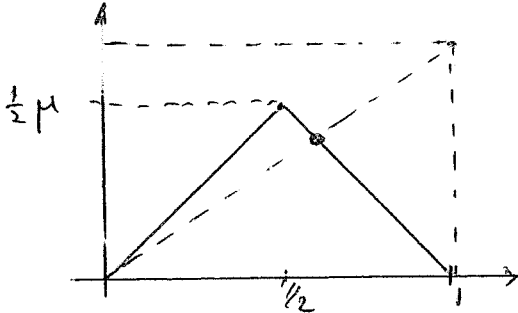

In this range the origin is unstable and the interval $[0, 1]$ is mapped into itself. There is a fixed point $x_0 = \mu/(1 + \mu)$, which is always unstable (exercise).

We show that the map is chaotic[G] when $1 < \mu \leq 2$.

Step 1. All non-zero orbits eventually enter and stay in the interval $A = [f^2(\frac{1}{2}), f(\frac{1}{2})] = [\mu(1 - \mu/2), \mu/2]$. Note that if the preimage of x_0 , $[x_{-1} = 1/(1 + \mu)] \in A$; i.e. if $1/(1 + \mu) > \mu(1 - \mu/2)$ then $\mu > \sqrt{2}$.

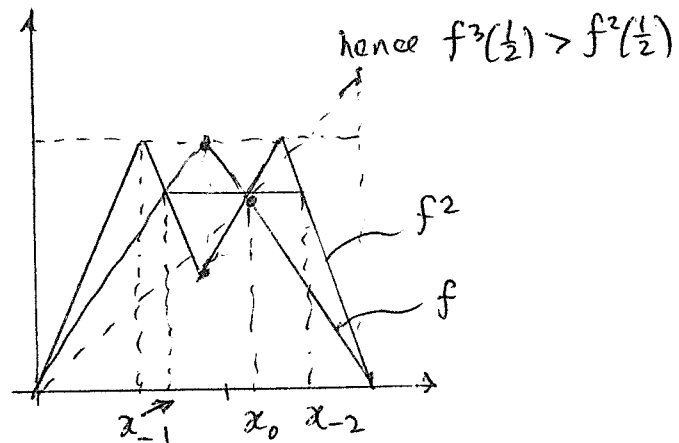
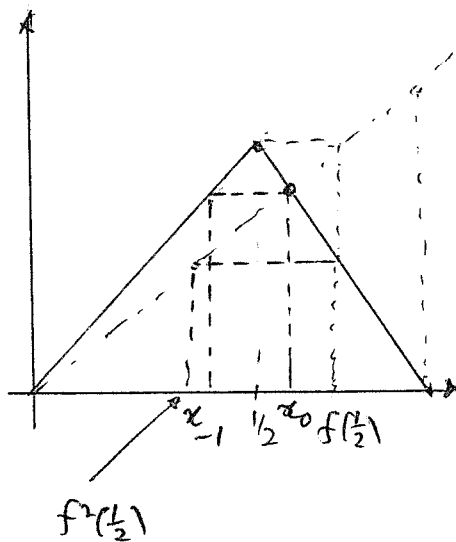

Step 2. Now consider $f^2(x)$:

$f^2(x) = \mu^2 x$	$0 \leq x \leq 1/2\mu$
$\mu(1 - \mu x)$	$1/2\mu \leq x \leq \frac{1}{2}$
$\mu(1 - \mu(1 - x))$	$\frac{1}{2} \leq x \leq 1 - 1/2\mu$
$\mu^2(1 - x)$	$1 - 1/2\mu \leq x \leq 1$

Let x_{-2} be the preimage under f of x_{-1} (Or the preimage under f^2 of the fixed point x_0 in $x > \frac{1}{2}$). Then $x_{-2} = (\mu^2 + \mu - 1)/\mu(\mu + 1)$.

Step 3. By a change of coordinates we can see that f^2 acts like a tent map with parameter μ^2 on the two intervals $J_L = [x_{-1}, x_0]$ and $J_R = [x_0, x_{-2}]$.

Two different cases:

For $\mu < \sqrt{2}$, (see picture for $\mu = 1.3$), f^2 gives tent maps with parameter μ^2 on the intervals $[x_{-1}, x_0]$ and $[x_0, x_{-2}]$, and the attracting set (shaded) has two components defined by $f^i(\frac{1}{2})$, $i = 1, \dots, 4$ (circles).

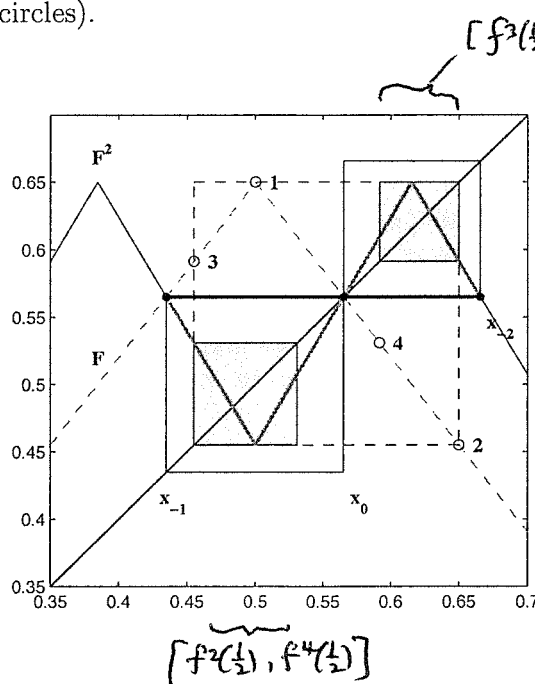

$f^2(\frac{1}{2}) > x_{-1}$
 $\Rightarrow f^3(\frac{1}{2}) > x_0$
 (consider f in (x_{-1}, x_0))

For $\mu > \sqrt{2}$, (see picture for $\mu = 1.5$), f^2 has horseshoes on the intervals $[x_{-1}, x_0]$ and $[x_0, x_{-2}]$, and the attracting set (shaded) has one component since $f^4(\frac{1}{2}) > f^3(\frac{1}{2})$.

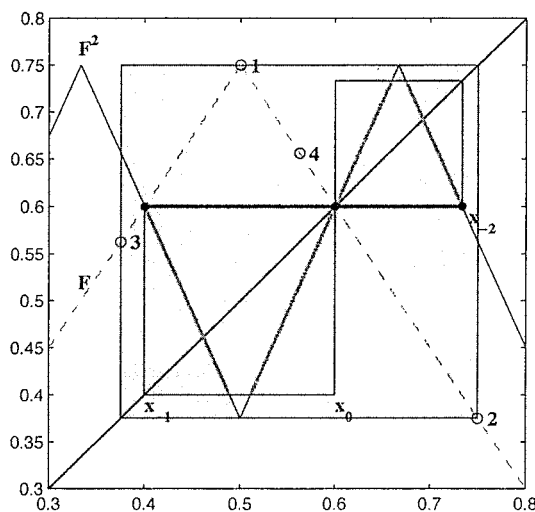

$f^2(\frac{1}{2}) < x_{-1}$

Step 4. Now suppose that $\sqrt{2} \leq \mu^{2^n} < 2$. Then $f^{2^{n+1}}$ has a horseshoe on 2^n intervals that are permuted by f . Proof: apply above arguments inductively.

The union of all the intervals $[2^{1/2^{n+1}}, 2^{1/2^n})$ is the complete range $1 < \mu < 2$.

The following images of the (μ, x) plane were produced by iterating the tent map for $O(1000)$ iterations to allow the orbit to settle towards the chaotic attractor, and then plotting successive iterations whilst slowly varying the parameter μ .

The attracting set contains 2^n intervals in $2^{1/2^{n+1}} \leq \mu < 2^{1/2^n}$, i.e. 1 interval in $1.414 \dots \leq \mu < 2$, 2 intervals in $1.189 \dots \leq \mu < 1.414 \dots$, 4 intervals in $1.091 \dots \leq \mu < 1.189 \dots$.

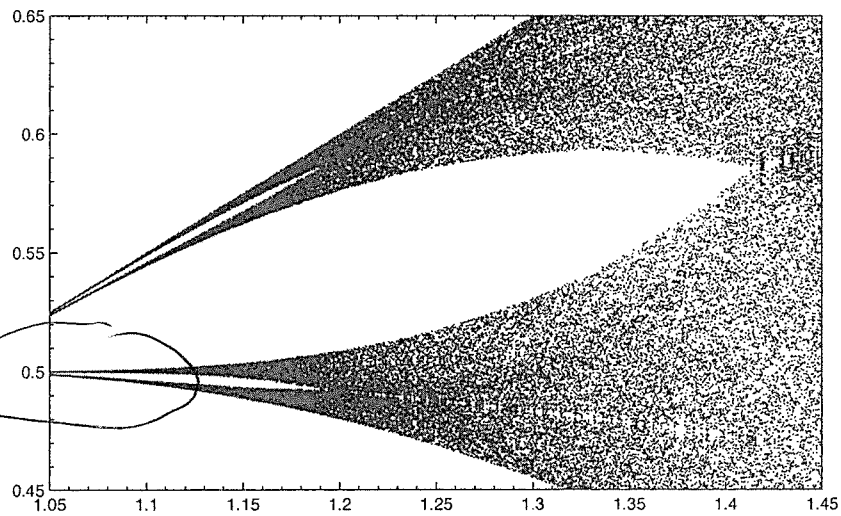

magnified

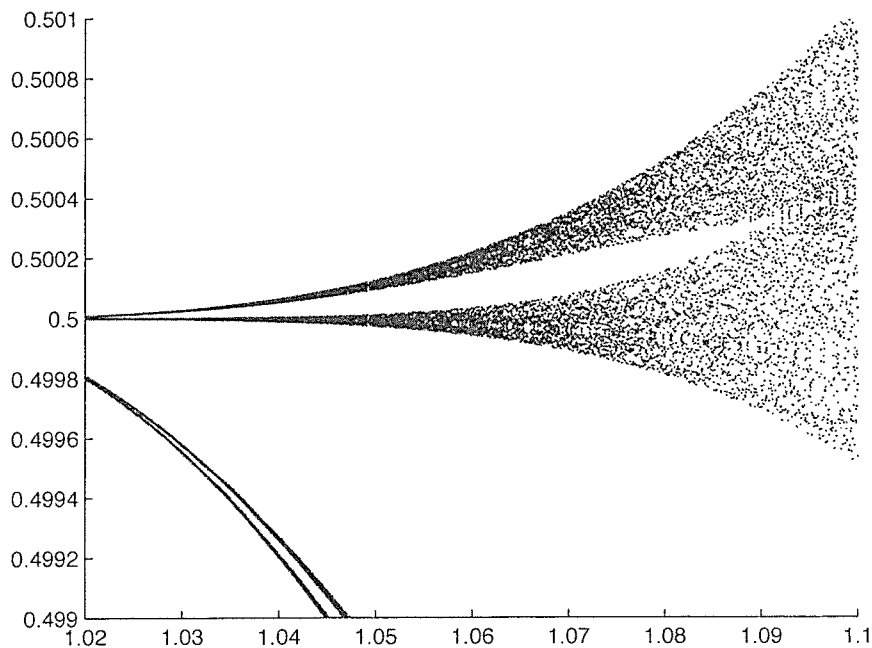

7.7 Unimodal Maps

7.7.1 The Logistic Map

The Logistic Map is defined by $x_{n+1} = \mu x_n(1 - x_n)$, $0 < \mu \leq 4$. For pictures of the bifurcation structure of the map see:

<http://www.damtp.cam.ac.uk/user/phh/dynsys/logisticmappictures.pdf> or look for better quality pictures elsewhere, e.g.,

http://en.wikipedia.org/wiki/File:LogisticMap_BifurcationDiagram.png.

There is one non-trivial fixed point at $\bar{x} = (\mu - 1)/\mu$. Jacobian is $\mu(1 - 2\bar{x}) = 2 - \mu$, so there is a period-doubling bifurcation at $\mu = 3$. By looking at iterates of the map we find a further bifurcation (to period 4) at $\mu = 1 + \sqrt{6}$; to period 8 at $\mu \approx 3.544$. Call μ_k point of bifurcation to cycle of period 2^k ; then it was shown by Feigenbaum (1978) that

$$\delta = \lim_{k \rightarrow \infty} \left(\frac{\mu_k - \mu_{k-1}}{\mu_{k+1} - \mu_k} \right) = 4.6692 \dots \text{Feigenbaum's constant; } \mu_k \rightarrow \mu_\infty = 3.5699 \dots$$

This ratio turns out to be a *universal* constant for all one-humped (unimodal) maps with a quadratic maximum (at $x = \frac{1}{2}$ for the logistic map). First we give some general results about such maps.

7.7.2 General Properties of Unimodal Maps

Definition 35 A *unimodal map* on the interval $[a, b]$ is a continuous map $F : [a, b]$ into $[a, b]$ such that (i) $F(a) = F(b) = a$ and (ii) $\exists c \in (a, b)$ such that F is strictly increasing on $[a, c]$ and strictly decreasing on $[c, b]$. i.e.

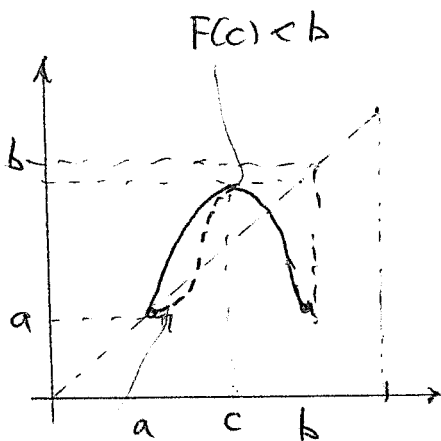

Note: a map of the form

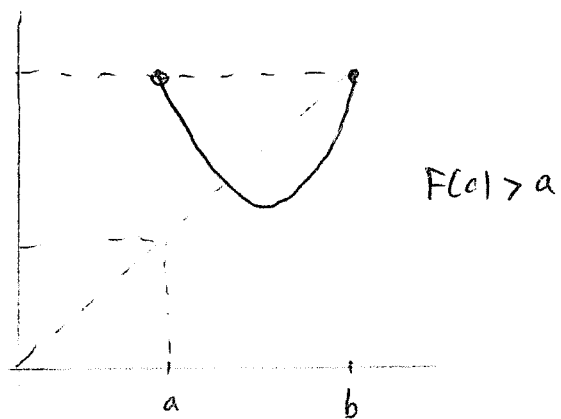

2nd possible form

is effectively unimodal under $x \mapsto -x$ and $F \mapsto -F$.

Definition 36 An *orientation reversing fixed point (ORFP)* of a unimodal map F is a fixed point in the interval (c, b) where F is decreasing.

Lemmas

- (1) If $F(c) \leq c$ then all solutions tend to fixed points, which lie in $[a, F(c)]$.
- (2) If $F(c) > c$ then there is a unique ORFP $x_0 \in (c, F(c))$.
- (3) If $F(c) > c$ then either $[F^2(c), F(c)]$ maps into itself (and therefore contains an attractor, in which case we refer to $[F^2(c), F(c)]$ as an attracting set) or if it does not then F has a horseshoe. (There may also be attracting fixed points in $[a, F^2(c)]$.)

Proof

(1) $F([a, c]) = F([c, b]) = [a, F(c)] \subseteq [a, c]$. So after one iteration $x_1 \in [a, c]$, where $x < y \iff F(x) < F(y)$.

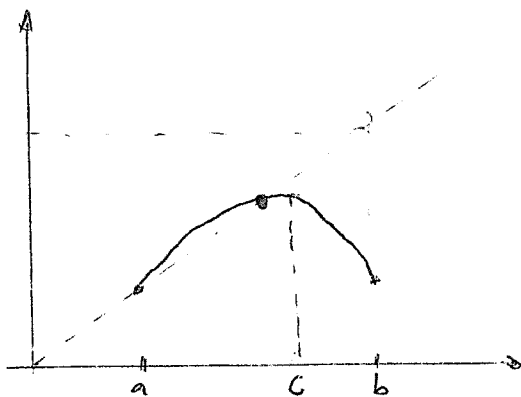

If $x_1 < F(x_1)$ then x_i increases monotonically to the nearest fixed point.

If $x_1 > F(x_1)$ then x_i decreases monotonically to the nearest fixed point.

(2) Apply the IVT to $F(x) - x$ on $[c, F(c)]$ noting that $F(c) > c \implies F^2(c) < F(c)$. Note that $x_0 \in [c, F(c)]$ where F is decreasing, implies that $F^2(c) < x_0 < F(c)$.

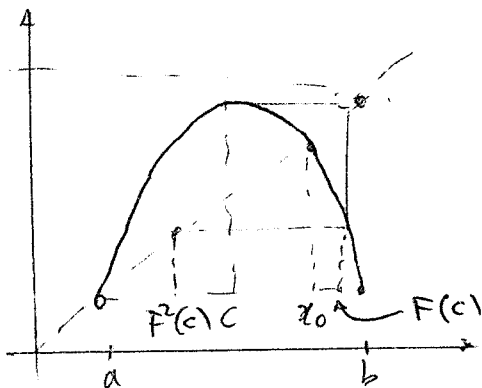

(3) Consider whether $F^3(c) < F^2(c)$ or vice versa. If $F^2(c) < F^3(c)$ then $[F^2(c), F(c)]$ maps into itself. (Exercise). If $F^2(c) > F^3(c)$ then first note $F^2(c) < c$ since $F(x) \geq x$ for $x \in [c, x_0]$. Further by IVT there is a fixed point y_0 of F with $F^2(c) < y_0 < c$ and hence $F(y_0) < F(c)$. By IVT define $z_0 \in [c, F(c)]$ (uniquely) such $F(z_0) = F(y_0) < F(c)$. The

interval (y_0, z_0) then has a horseshoe. ($\because z_0 < F(c)$)

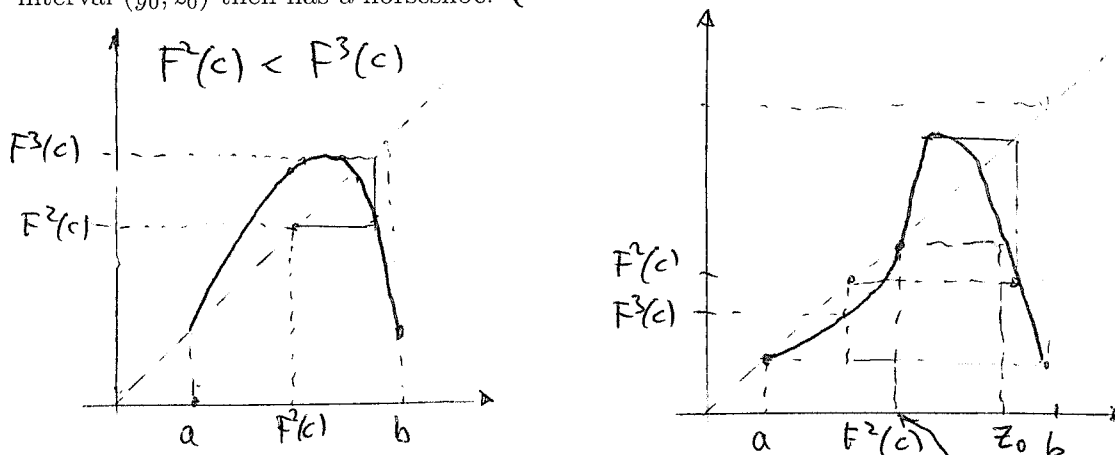

Theorem 17 If F has an ORFP x_0 then $\exists x_{-1} \in (a, c)$ and $x_{-2} \in (c, b)$ such that $F(x_{-2}) = x_{-1}$ and $F(x_{-1}) = x_0$. Moreover,

- either (i) F^2 has a horseshoe on $J_L \equiv [x_{-1}, x_0]$ and $J_R \equiv [x_0, x_{-2}]$
- or (ii) all solutions tend to fixed points of F^2
- or (iii) F^2 is a unimodal map with an ORFP on both J_L and J_R .

Proof

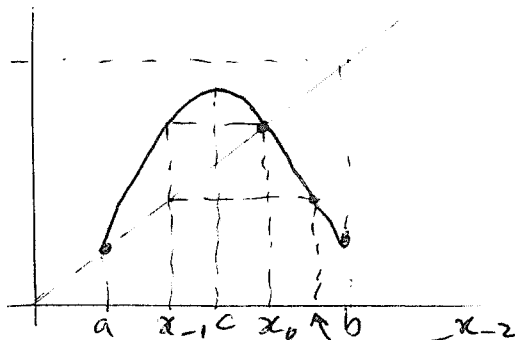

$F(a) = a < c < x_0, F(c) > F(x_0) = x_0 \xrightarrow{IVT} \exists x_{-1} \in (a, c)$ such that $F(x_{-1}) = x_0$.

$F(x_0) = x_0 > c > x_{-1}, F(b) = a < x_{-1} \xrightarrow{IVT} \exists x_{-2} \in (x_0, b)$ such that $F(x_{-2}) = x_{-1}$.

Thus $F^2(x_{-2}) = F^2(x_{-1}) = F^2(x_0) = x_0$. Also $x \in [x_{-1}, x_0] \Rightarrow F^2(x) \in [F^2(c), x_0]$ and $x \in [x_0, x_{-2}] \Rightarrow F^2(x) \in [x_0, F(c)]$ i.e. F^2 has the graph

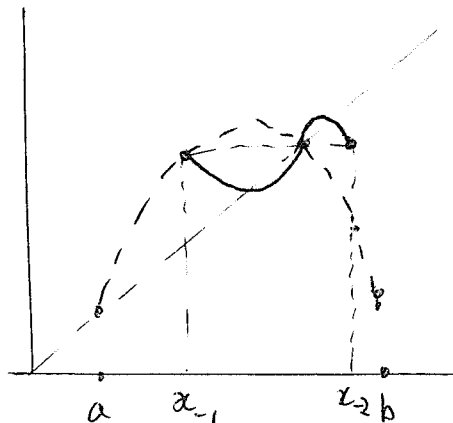

(i) If $F^2(c) < x_{-1}$ (equivalent to $F(c) > x_{-2}$) then F^2 has horseshoes.

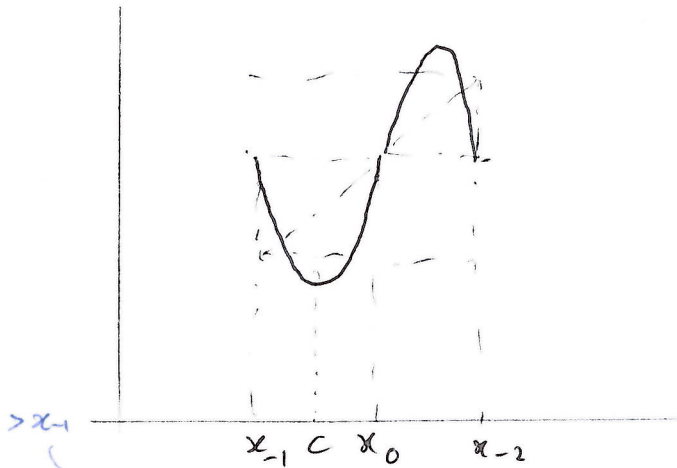

and lemma 23

(ii) If $F^2(c) > c$ (equivalent to $F(c) < c_{-1}$ where $c_{-1} > c$ and $F(c_{-1}) = c$) then F^2 is a unimodal map without an ORFP on each of J_L and J_R . Hence (by previous lemma) all solutions on $J_L \cup J_R$ tend to fixed points of F^2 . All solutions on $[a, x_{-1}] \cup [x_{-2}, b]$ either tend to fixed points of F or are attracted into $[F^2(c), F(c)] \subset J_L \cup J_R$.

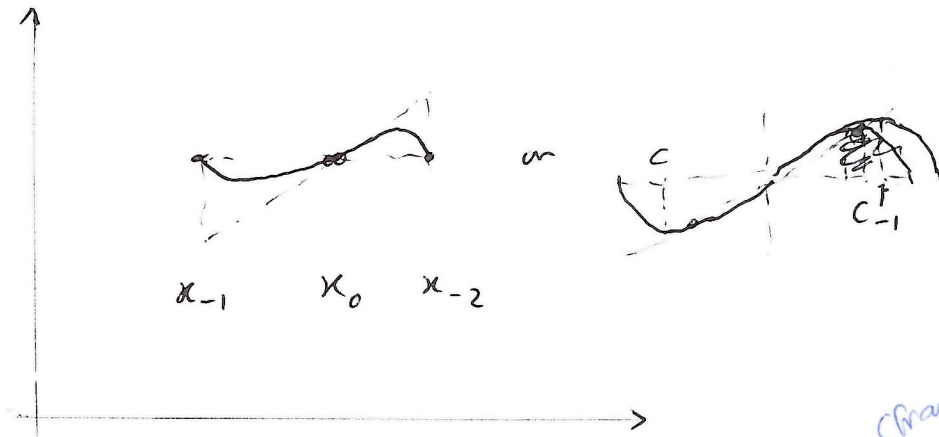

(from previous result)

(iii) If $x_{-1} < F^2(c) < c$ then F^2 is a unimodal map with an ORFP on each of J_L and J_R . Each unimodal map has an attracting subinterval or if not has a horseshoe. The ORFPs correspond to a 2-cycle of F , and the attracting set consists of two disjoint subintervals.

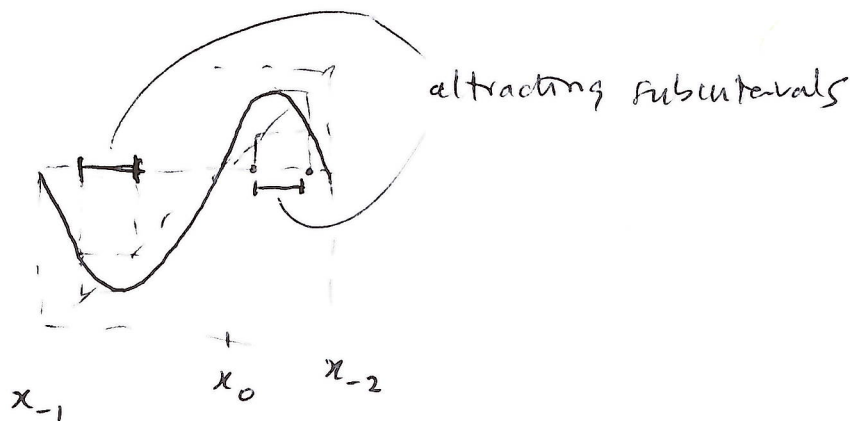

Applying Theorem 17 successively to F^2, F^4, F^8, \dots we deduce that

Theorem 18 *If F has an ORFP then*

- either (i) $\exists N$ such that F^{2^N} has a horseshoe and F is chaotic
- or (ii) $\exists N$ such that all solutions tend to fixed points of F^{2^N} and F has 2^m -cycles for $0 \leq m \leq N - 1$
- or (iii) there are (mostly unstable) 2^m -cycles $\forall m$, and the attracting set is a Cantor set formed by the infinite intersection, over all m , of the attracting subintervals of F^{2^m} .

Proof Induction on previous results (except for the comment on stability which depends on the following).

7.7.3 Scaling Invariance and Feigenbaum's Constant

If we write $G_k = F^{2^k}$ then in situation (iii) of Theorem 18 the successive subgraphs of G_{k+1}, G_{k+2}, \dots all seem to look the same after renormalisation and all seem to have the same properties. This suggests that we look for a graph that is invariant under iteration and renormalisation:

Suppose w.l.o.g that $c = 0$ and after renormalisation $G_k(0) = 1 \forall k$. (This is easier than scaling the sub-interval so that the end x_0 is always at 1.) Let λ be the value of $G_k^2(0) = G_k(1)$.

See the Figure for typical graphs of G_k and G_k^2 .

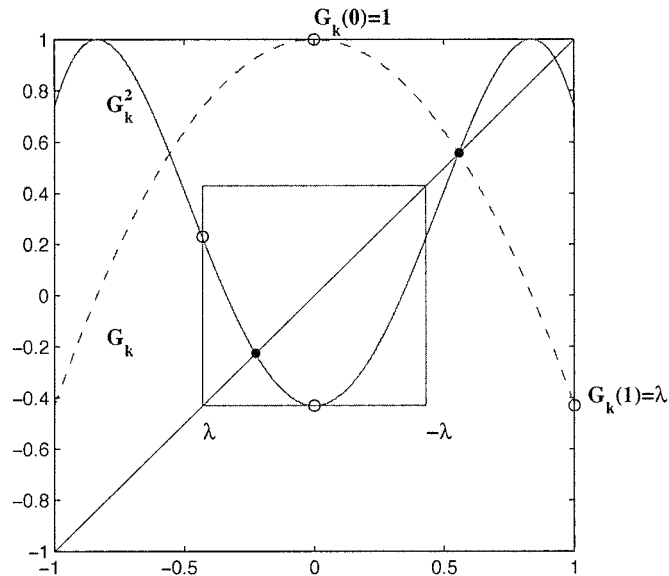

Renormalise G_k^2 so that $G_{k+1}(0) = 1$ by defining

$$G_{k+1}(y) = \frac{G_k^2(\lambda y)}{\lambda} \equiv \mathcal{T}[G_k]$$

Now seek a function \bar{G} such that $\bar{G} = \mathcal{T}[\bar{G}]$, i.e. \bar{G} is invariant under renormalisation.

Suppose that $\bar{G}(x) = \bar{G}(-x) = 1 + ax^2 + bx^4 + \dots$

To get an approximation to \bar{G} try a truncated series expansion:

e.g. $G_k = 1 + a_k x^2 + o(x^2)$ with $G_k(1) = 1 + a_k = \lambda_k$

$$\Rightarrow G_{k+1} = \mathcal{T}[G_k] = \frac{1 + a_k \{1 + a_k [(1 + a_k)x]^2\}^2}{1 + a_k} = 1 + 2a_k^2(1 + a_k)x^2 + o(x^2)$$

i.e. $a_{k+1} = 2a_k^2(1 + a_k)$, which has an unstable fixed point $\bar{a} = -\frac{1}{2}(1 + \sqrt{3}) = -1.37 \Rightarrow \bar{\lambda} = -0.37$, where the Jacobian of \mathcal{T} evaluated at the fixed point is $4 + \sqrt{3} = 5.73$

e.g. $G_k = 1 + a_k x^2 + b_k x^4 + o(x^4)$ with $G_k(1) = 1 + a_k + b_k = \lambda_k$ gives the 2D map

$$a_{k+1} = 2a_k(a_k + 2b_k)\lambda_k \quad b_{k+1} = (2a_k b_k + a_k^3 + 4b_k^2 + 6a_k^2 b_k)\lambda_k^3$$

which has a fixed point $\bar{a} = -1.5222$, $\bar{b} = 0.1276$, $\bar{\lambda} = -0.3946$, where the Jacobian has eigenvalues 4.844 and -0.49 .

In fact, numerical solution shows that the functional map \mathcal{T} has a fixed point $\bar{G} = \mathcal{T}[\bar{G}]$, where

$$\bar{G} = 1 - 1.52736x^2 + 0.10482x^4 - 0.02671x^6 + \dots, \quad \bar{\lambda} = \bar{G}(1) = -0.3995$$

The function \bar{G} has a single unstable fixed point and linearisation about $\mathcal{T}[\bar{G}] = \bar{G}$ to give the Jacobian gives a single eigenvalue $\delta = 4.6692016\dots$ outside the unit circle, and an infinite spectrum of eigenvalues inside the unit circle. Hence situation (iii) of Theorem 18 (renormalisation possible infinitely often) is unstable in one direction; the stable manifold occupies 'all but one dimension' of the possible space of functions.

The function $G_0 = \mu_\infty x(1-x)$, $\mu_\infty = 3.5700\dots$, where μ_∞ is the value to which the period-doubling sequence of the logistic map converges is on the stable manifold of \bar{G} (under the dynamical system defined by repeated application of \mathcal{T}). But, considering repeated application of \mathcal{T} to the function $\mu x(1-x)$ where $\mu \neq \mu_\infty$ implies a small perturbation away from G_0 which grows to give situation (i) if $\mu > \mu_\infty$ (G_N has a horseshoe for some N) or situation (ii) if $\mu < \mu_\infty$ (G_N has no ORFP for some N and cycle lengths divide 2^N).

If $\mu_\infty - \mu = O(\delta^{-N})$ then it takes $O(N)$ renormalisations for the perturbation to grow to $O(1)$ and eliminate the ORFP, thus explaining why $\mu_\infty - \mu_K \sim A\delta^{-K}$ as $K \rightarrow \infty$, where μ_K is the value of μ at which the period doubles to 2^K . This is the behaviour explained by Feigenbaum.

